

## VBF2, VBF3 Control Ball Valves with Flanged Connections

### PRODUCT DATA AND INSTALLATION INSTRUCTIONS



### FEATURES

#### All Models

- PN 25 (DN 50 ... DN 80), PN 16 (DN 100 ... DN 150).
- Equal percentage or linear flow characteristics.
- Flanged connections fitting flanges conforming to EN 1092-1.
- Temperature range of medium: -30...+120 °C.
- Choice of actuation-control scheme: Floating, modulating (2...10 V), spring-return 24 V 2-position, spring-return modulating / floating.
- Field-configurable for normally-open or normally-closed fail-safe position.
- Removable manual operating handle to control valve during installation or in the event of a power failure (DN 50 ... DN 80).
- Option of four actuator mounting positions on the valve.
- Wide range of  $K_{vs}$  choices, from 25 to 560 m<sup>3</sup>/h.
- Valve ball and stem made of 316 stainless steel.

### APPLICATION

The VBF2 Two-Way and the VBF3 Three-Way Control Ball Valves are designed for use in heating, ventilating and air conditioning (HVAC) systems to provide two-position or modulating functions.

These valves can be used with listed Honeywell actuators.

### Proper Use

#### IMPORTANT

*Valve sizing is important for correct system operation. Undersized valves do not have sufficient capacity at max. load. Oversized valves do not have sufficient authority over the load in modulating applications. Oversized valves can cause excessive cycling and the seat and ball can be damaged.*

*The presence of excessive iron oxide (red rust) in the system voids the valve warranty.*

These valves are for use only in cold, warm, and hot water systems. They are designed for a medium temperature range of from -30 to 120 °C, at a max. pressure of 2500 kPa for DN 50 and DN 80 valves and 1600 kPa for DN 100, 125, and 150 valves. The valves are to be operated only with suitable Honeywell actuators (see Table 3).

At low medium temperatures, suitable measures must be taken to prevent condensation in and at the actuator.

The installation of strainers and filters is recommended.

#### VBF2 (two-way)

- EN 1349 Class IV leakage specification (0.01 % of  $K_{vs}$ ).

#### VBF3 (three-way)

- **Mixing or diverting control and EN 1349 Class IV leakage specification (0.01 % of  $K_{vs}$ ) for all sized except as noted below.**
- **VBF3 DN 100 ... 150:**
  - Mixing control, only.
  - Class IV (0.01 % of  $K_{vs}$ ) leakage from A to AB.
  - Class III (0.1 % of  $K_{vs}$ ) leakage from B to AB.

Globe value A-B-AB flow pattern.

## SPECIFICATIONS

<b>Models:</b>	See Table 1 and Table 2.
<b>Dimensions:</b>	See Fig. 18 through Fig. 22.
<b>Body style:</b>	
DN 50 ... 80:	With straight-through flow, full or reduced port using patented flow control insert.
DN 100 ... 150:	With A-B-AB characterized flow, using laser-milled stainless steel control ball.
Flange connection:	Combination EN 1092-1 DN 125 / PN16 flanged connection.
<b>Body size:</b>	DN 50, 65, 80, 100, 125, and 150.
<b>Flow capacity:</b>	See Table 1 and Table 2.
<b>Pressure Rating at 120 °C (max.):</b>	
DN 50 ... 80:	PN25
DN 100 ... 150:	PN16
<b>Flow Characteristics:</b>	
Two-way ball valve:	Equal Percentage.
Three-way ball valve:	Port A to AB: Equal Percentage. Port B to AB: Linear with 20% reduced flow capacity.

<b>Controlled Medium:</b>	Water or glycol solutions up to 50% according to VDI 2035 Bl. 2.
<b>Fluid Temp. Range:</b>	-30 <sup>(1)</sup> to +120 °C.
<b>Mounting:</b>	Fitting flanges PN 16 (in case of valves < DN 100, also PN25) according to EN 1092-1.
<b>Materials:</b>	
Body:	Brass (DN 50 ... 80); cast iron ASTM A395, 60-40-18 (DN 100 ... 150)
Ball and Stem:	Nickel-plated brass (DN 50 ... 80); 316 stainless steel (DN 100 ... 150).
Stem Seals:	EPDM O-Rings.
Ball Seals:	Teflon™ Seals.
<b>Approvals/Standards:</b>	
2-way:	EN 1349 Class IV leakage.
3-way (DN 50...80):	EN 1349 Class IV leakage.
3-way (DN 100...150):	A to AB: EN 1349 Class IV leakage. B to AB: EN 1349 Class III leakage.
<b>Actuators:</b>	See Table 3.
<b>Accessories:</b>	See Fig. 16.

<sup>(1)</sup> At low medium temperatures, suitable measures must be taken to prevent condensation in and at the actuator.

**Table 1. Flow capacities and close-off pressure ratings (two-port valves)**

Two-port valve			Close-off pressure (kPa) with actuators (see Table 3)		
DN	Kvs (m <sup>3</sup> / h)	Order number	10 Nm	20 Nm	20 Nm (2-pos.), 34 Nm
DN 50	25	VBF2-50-25	700	--	--
DN 50	40	VBF2-50-40	700	--	--
DN 65	63	VBF2-65-63	700	--	--
DN 80	100	VBF2-80-100	700	--	--
DN 100	160	VBF2-100-160	--	500	500
DN 125	250	VBF2-125-250	--	500	500
DN 150	320	VBF2-150-320	--	--	500
DN 150	400	VBF2-150-400	--	--	500
DN 150	560	VBF2-150-560	--	--	500

**Table 2. Flow capacities and close-off pressure ratings (three-port valves)**

Three-port valve			Close-off pressure (kPa) with actuators (see Table 3)		
DN	Kvs (m <sup>3</sup> / h)	Order number	10 Nm	20 Nm	20 Nm (2-pos.), 34 Nm
DN 50	25	VBF3-50-25	275	--	--
DN 50	40	VBF3-50-40	275	--	--
DN 65	63	VBF3-65-63	275	--	--
DN 80	100	VBF3-80-100	--	500	500
DN 100	160	VBF3-100-160	--	500	500
DN 125	250	VBF3-125-250	--	500	500
DN 150	320	VBF3-150-320	--	--	500
DN 150	400	VBF3-150-400	--	--	500
DN 150	560	VBF3-150-560	--	--	500

## Suitable Actuators

The VBF2 and VBF3 valves are designed for use with suitable Honeywell actuators. The use of higher-torque actuators is permitted, but will not increase the close-off pressure rating.

**Table 3. Suitable actuators**

Control	DN 50 ... 80	DN 100 / 125	DN 150
Floating NSR 24V	N1024	N2024	N3424
Floating NSR 230V	N10230-2POS	N20230	N34230
Modulating NSR	N10010	N20010	N34010
2-Position SR	S0524-2POS	S2024-2POS	S2024-2POS
Floating / modulating 24V SR	S05010	S20010	S20010

## INSTALLATION

### Before Beginning

1. Read these instructions carefully. Failure to follow them could damage the product or cause a hazardous condition.
2. Check ratings given in instructions and on the product to ensure the product is suitable for your application.
3. Installer must be a trained, experienced service technician.
4. After installation is complete, check out product operation as provided in these instructions.



### CAUTION

#### Risk of equipment damage!

- ▶ Foreign particles like dirt and metal chips can damage the ball seals.
- ▶ For trouble-free operation of the product, good installation practice must include initial system flushing. Clean the lines upstream of particles more than 1.5 mm in diameter (welding slag, pipe scale, sand, and other suspended particulate). Use of a 50 micron (or finer) system side-stream filter is recommended.
- ▶ Do not use boiler additives, solder flux, and wetted materials which are petroleum-based or contain mineral oil, hydrocarbons, or ethylene glycol acetate. Compounds which can be used, with minimum 50% water dilution, are: diethylene glycol, ethylene glycol, and propylene glycol (antifreeze solutions).
- ▶ If installing these valves in an addition to, or retrofitting an existing building, do not assume that the fluid in the existing piping meets these criteria.
- ▶ Medium must be in accordance with VDI 2035 Bl. 2.

## Safety

The valves are to be installed by skilled personnel and in strict accordance with the installation instructions and local regulations. Honeywell assumes no responsibility for damages or injuries resulting from non-compliance with installation instructions or standard good practice when mounting, operating, or maintaining the valves, even if not explicitly mentioned in the installation instructions. Observe all safety practices.

## Mechanical Installation

### IMPORTANT

1. Two-way valves are marked to show flow direction.
2. Flow arrows must point in the direction of the flow for proper operation.

## Valve Installation Location

Select a location where the valve and actuator will be accessible once installed. Allow sufficient space for servicing the valve and actuator. Clearance for valve installation is dependent on actuator size and the valve pipe size. See Fig. 18 through Fig. 22 for valve body dimensions. Refer to actuator literature for actuator dimensions.

**NOTE:** Do not lift the valve by the stem!

## Mounting Valve

1. Before installing the valve, rotate the valve stem to make sure that the valve stem operates freely. Impaired stem operation can indicate that the stem was bent by rough handling. This condition can require replacing the valve.
2. Protect the stem from damage due to bending or scratching.
3. For horizontal piping, install the valve so the actuator is above the valve body. Install the valve in any position between vertical and horizontal. Do not install the valve with the stem below horizontal or upside down. For vertical piping, the actuator can be mounted in any orientation.
4. Hoist valve by its body only. Do not lift by stem, bonnet, flanges, or flange holes. (See Fig. 1 for proper hoisting method.)

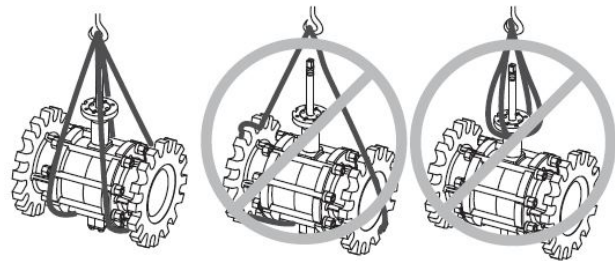

**Fig. 1. Proper hoisting of VBF valves**

5. Mount the valve between aligned pipes. Mounting the valve on pipes that are not aligned causes leakage at the valve-to-pipe connection.



Fig. 2. Piping must prevent leakage

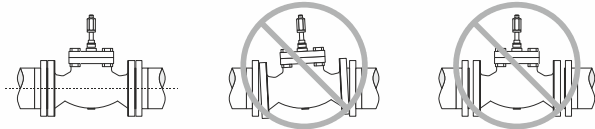

Fig. 3. Basic pipe orientation

6. Iron valves are mechanically compatible with standard EN 1092-1 PN16 / PN25 flat-faced or raised-face steel flanges.
7. Release system pressure and drain the valve pipe section so the medium (water or glycol solution) does not leak out of the valve body during installation.
8. Mount three-way valves as shown in Fig. 6, depending upon whether they are to be used for mixing or diverting control.
9. Use a gasket material recommended for the medium to be handled. Valves DN 50 ... 80 do not require an additional gasket.
10. Use M16 (for DN 50...125) or M20 (for DN 150) mounting bolts and washers. The bolts should be long enough so that the nuts can use the full length of the nut threads. Use four (for DN 50) or eight (for DN 65...150) bolts to connect.

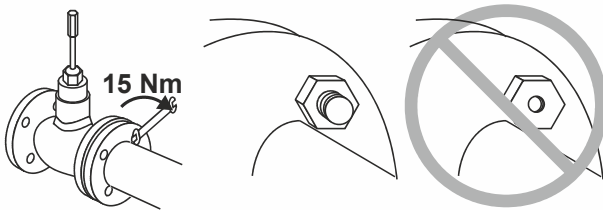

Fig. 4. Basic proper bolt length

## Typical Operation

All types of valves should be mounted in the return flow. If the  $D_p$ -values exceed 300 kPa, attention should be paid to the development of noise.

### Two-Way Valves

Direction of flow always from port A to port B.  
Port B: Outlet

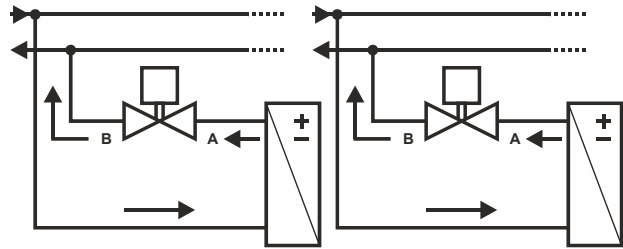

Fig. 5. Two-way valve operation

### Three-Way Valves

These valves are used preferably as mixing valves. This means:

Port AB: Total flow outlet

Port A: Controlled flow inlet

Port B: Bypass inlet

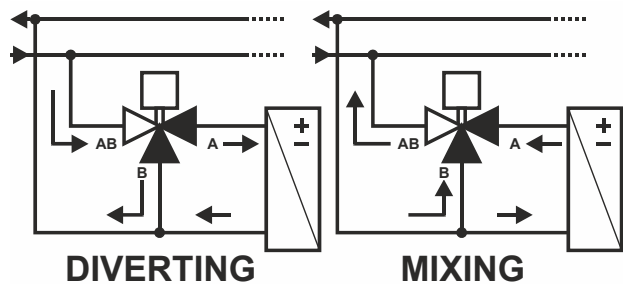

Fig. 6. Three-way control ball valve operation, diverting and mixing (not to scale)

### Stem Rotation

- For two-way valves:
  - Clockwise to close.
  - Counterclockwise to open.
- For three-way valves:
  - Clockwise to increase B to AB flow.
  - Counter clockwise to increase A to AB flow.

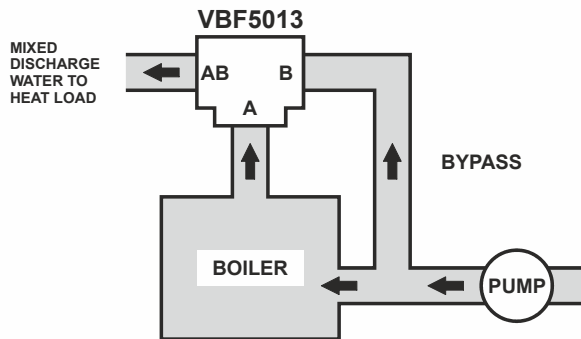

Fig. 7. Boiler bypass for reset control

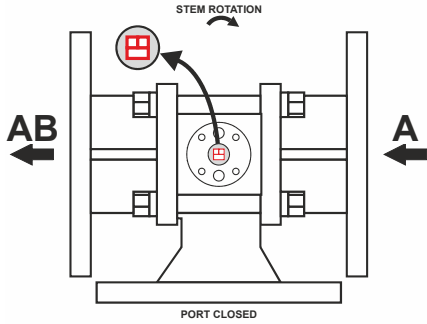

Fig. 8. Stem rotation, coil flow

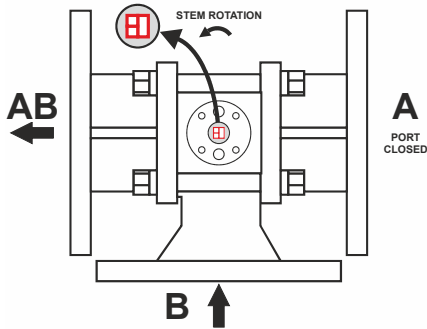

Fig. 9. Stem rotation, bypass flow

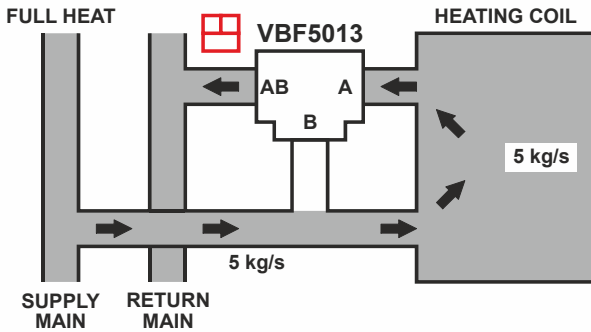

Fig. 10. Three-way mixing valve operation with coil bypass, full heat (not to scale)

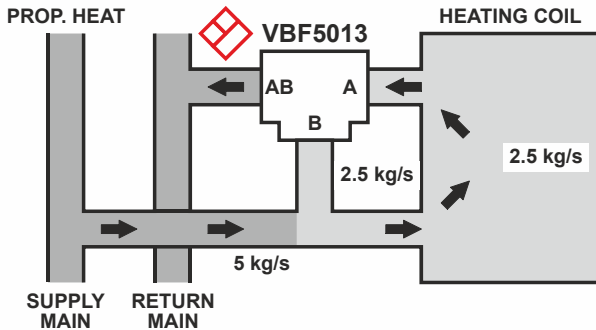

Fig. 11. Three-way mixing valve operation with coil bypass, proportioned heat (not to scale)

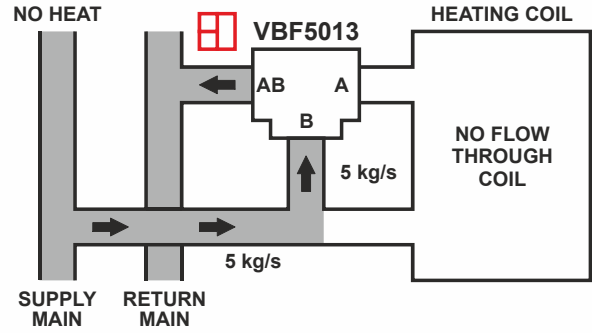

Fig. 12. Three-way mixing valve operation with coil bypass, no heat (not to scale)

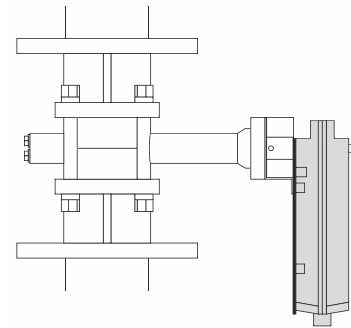

Fig. 13. Vertical installation of valve

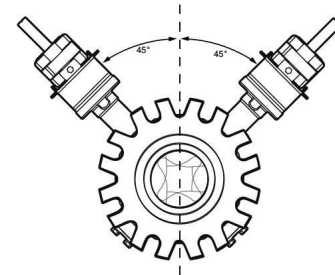

Fig. 14. Acceptable valve angle from vertical (when installed in horizontal piping)

### Actuator

For information on mounting and operating, refer to the Installation Instructions for the specific Honeywell actuator coupled to the valve. It is important to have the correct actuator available for the installation.

### General

Spring return actuators return the valve to its normal position (open or closed, depending on the actuator and valve selected) in the event of a power failure. Non-spring return actuators hold the last commanded position.

### Service Parts

There are no serviceable parts.

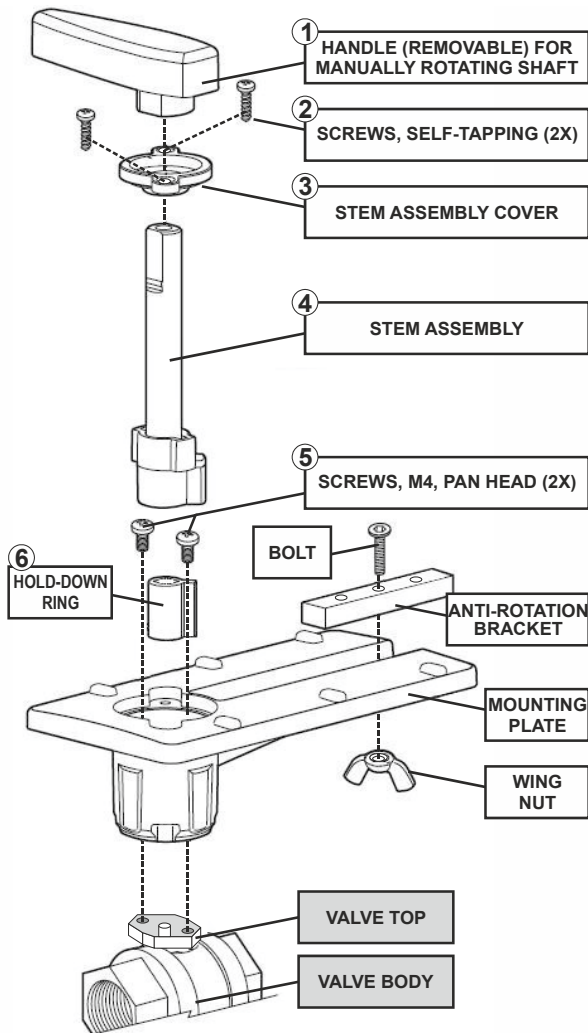

Fig. 15. Valve assembly, exploded view

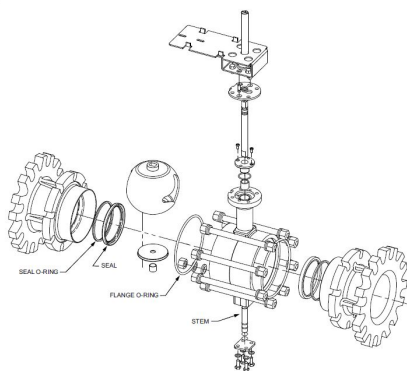

Fig. 16. Flanged ball valve, exploded view

## Mounting Plate Adjustment

The Actuator Mounting Plate can be rotated to a different position for installation in confined spaces. This is accomplished as follows:

### For DN 50 ... 80

1. Remove the handle (1) from the shaft and set it aside.
2. Remove the two screws (2) that hold the stem assembly cover (3) to the mounting plate and set them aside.
3. Remove and set aside the stem assembly (4).
4. Remove and set aside the two screws (5) that attach the mounting plate to the valve.
5. Remove and set aside hold-down ring (6) from mounting plate.
6. Rotate mounting plate around valve top to the desired position.

**NOTE:** Take note of the screw hole positions on the valve. They limit the mounting plate positions.

7. Lower ring (6) down to valve body and engage it in the new position relative to the mounting plate.
8. Tighten screws to valve body securing the mounting plate.
9. Reattach the stem assembly to the mounting plate.
10. If desired, replace the handle on the shaft.

**NOTE:** See Fig. 15 for valve exploded view.

### For DN 100 ... 150

1. Remove the four bolts and lock washers that hold the mounting plate to the valve stem housing and set them aside.
2. Rotate mounting plate around valve top to the desired position.

**NOTE:** There are four positions possible (increments of 90 degrees from each other) for the mounting plate position.

3. Once the mounting plate is in the desired position, reinsert the bolts through the lock washers and into the four bolt holes in the valve stem housing.
4. Tighten bolts to the valve body securing the mounting plate.

See Fig. 17 for location of mounting bolts.

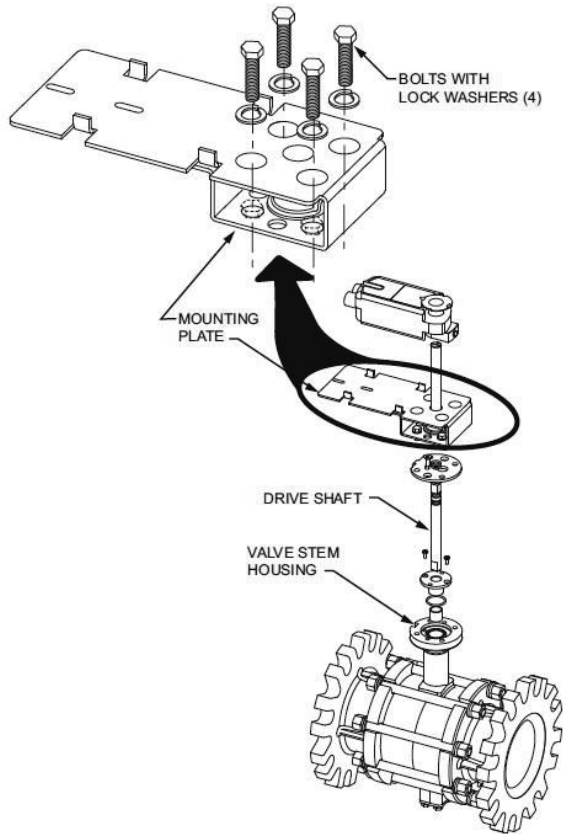

Fig. 17. Mounting plate adjustment bolts

## OPERATION AND CHECKOUT

Once both the mechanical and electrical installations are complete:

1. Cycle the actuator to verify that the direction of rotation suits the control sequence.
2. If the rotation direction is incorrect, check the actuator instructions.

## Electrical Installation

See following table.

Table 4. Related technical literature

Product Data Sheet	Product Lit. No.
N0524 / N1024, N05230-2POS / N10230-2POS NSR DCAs for Floating / 2-Position Control	EN0B-0447GE51
N05010 / N10010 NSR DCAs for Modulating, Floating, and 2-Position Control	EN0B-0478GE51
S1024-2POS / S10230-2POS, S2024-2POS / S20230-2POS SR DCAs for 2-Position Control	EN0B-0462GE51
S10010 / S20010 SR DCAs for Modulating and Floating Control	EN0B-0463GE51
N2024 / N20230, N3424 / N34230 DCAs for Floating / 2-Position Control	EN0B-0320GE51
N20010, N34010 NSR DCAs for Modulating Control	EN0B-0341GE51

## DIMENSIONS

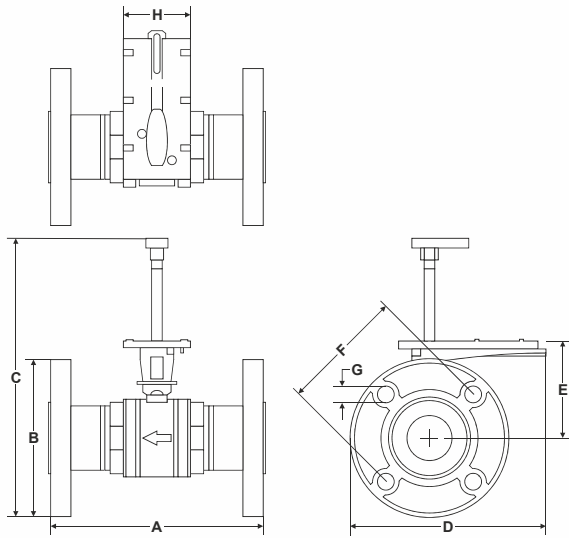

Fig. 18. Two-way DN 50 ... 80 valve dimensions

Table 5. Two-way DN 50 ... 80 valve dimensions

Model no.	VBF2-50-xx	VBF2-65-xx	VBF2-80-xxx
Size	DN 50	DN 65	DN 80
A	167	241 mm	279 mm
B	226	254 mm	267 mm
C	333	353 mm	360 mm
D	276	265 mm	269 mm
E	102	111 mm	111 mm
F	121	140 mm	152 mm
G	19	19 mm	19 mm
H	76	76 mm	76 mm

An elastic gasket is included in the flange delivery.

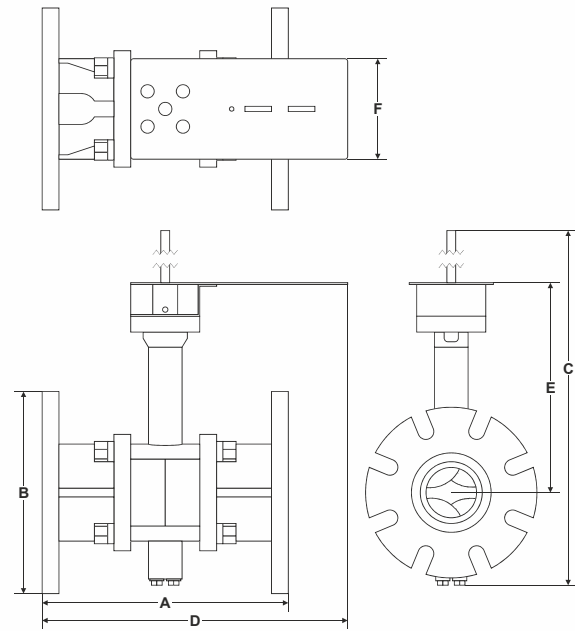

Fig. 19. Two-way DN 100 ... 150 valve dimensions

Table 6. Two-way DN 100 ... 150 valve dimensions

Model no.	VBF2-100-xxx	VBF2-125-xxx	VBF2-150-xxx
Size	DN 100	DN 125	DN 150
A	278 mm	314 mm	352 mm
B	229 mm	254 mm	277 mm
C	492 mm	509 mm	532 mm
D	345 mm	364 mm	382 mm
E	238 mm	246 mm	257 mm
F	114 mm	114 mm	114 mm

No gasket is included in the flange delivery.



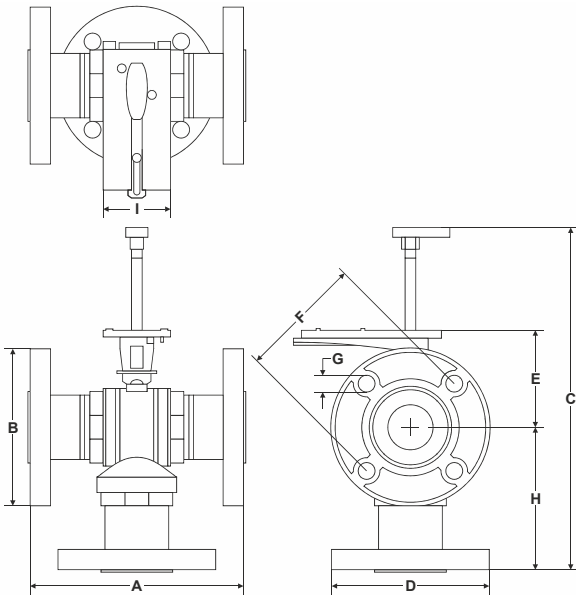

Fig. 20. Three-way DN 50 / 65 valve dimensions

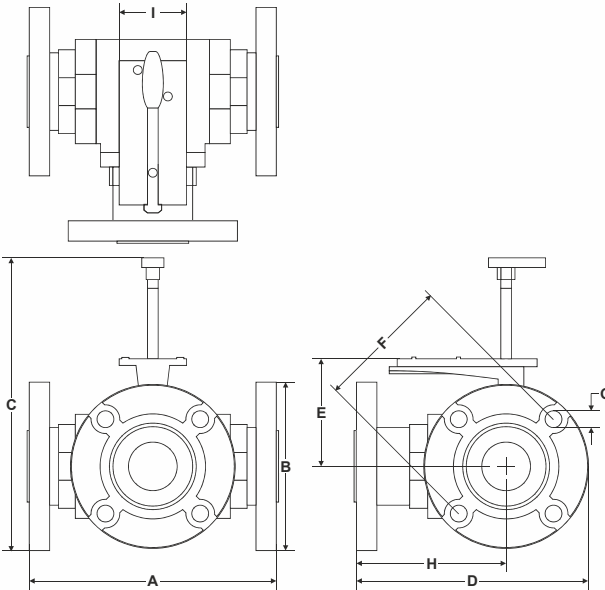

Fig. 21. Three-way DN 80 valve dimensions

Table 7. Three-way DN 50 ... 80 valve dimensions

Model no.	VBF3-50-xx	VBF3-65-xx	VBF3-80-xx
Size	DN 50	DN 65	DN 80
A	188	241 mm	279 mm
B	226	254 mm	242 mm
C	356	389 mm	329 mm
D	226	254 mm	263 mm
E	110	110 mm	123 mm
F	121	140 mm	153 mm
G	19	19 mm	19 mm
H	130	164 mm	168 mm
I	76	76 mm	76 mm

An elastic gasket is included in the flange delivery.

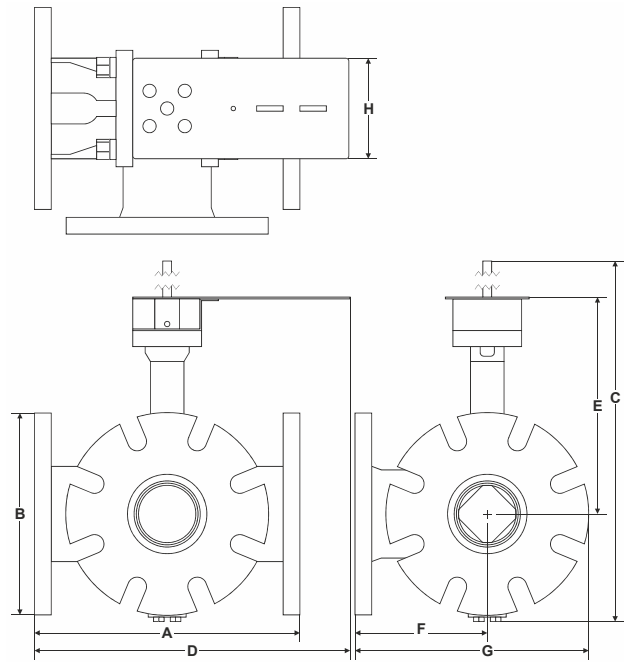

Fig. 22. Three-way DN 100 ... 150 valve dimensions

Table 8. Three-way DN 100 ... 150 valve dimensions

Model no.	VBF3-100-xxx	VBF3-125-xxx	VBF3-B1045/U
Size	DN 100	DN 125	DN 150
A	301 mm	352 mm	420 mm
B	229 mm	252 mm	279 mm
C	509 mm	532 mm	527 mm
D	358 mm	382 mm	416 mm
E	246 mm	257 mm	271 mm
F	150 mm	178 mm	271 mm
G	265 mm	304 mm	411 mm
H	114 mm	114 mm	114 mm

No gasket is included in the flange delivery.

---

Manufactured for and on behalf of the Connected Building Division of Honeywell Products and Solutions SARL, Z.A. La Pièce, 16, 1180 Rolle, Switzerland by its Authorized Representative:

**Home and Building Technologies**

Honeywell GmbH  
Böblinger Strasse 17  
71101 Schönaich, Germany  
Phone +49 (0) 7031 637 01  
Fax +49 (0) 7031 637 740  
<http://ecc.emea.honeywell.com>

EN1B-0677GE51 R0120

Subject to change without notice