

NXL Variable Speed Drives



Description

Variable motor speed drives suitable for a wide range of voltage and current loads. Convert fixed frequency and voltage from the mains supply to variable frequency and voltage enabling motors to be used with maximum efficiency resulting in significant energy savings. The drive has a built-in PID control application that can be adjusted from the control keypad.

NXL drives are suitable for mounting in a small space, using back, side, or DIN rail mounting.

The drives are easily programmed and commissioned by using the control keypad or PC tools software.

Features

- 380 to 500 Vac 3 phase or 208 to 240Vac single phase supply
- current rating range from 1.9 A to 61 A (0.37 kW to 30 kW)
- built-in multi-control application
- multilingual control panel
- integrated RFI filter for industry strength EMC
- versatile PC tools available
- slim, space-saving, "bookshelf" design
- additional I/O, 3 digital inputs, 2 digital outputs (Ecodrives only)

Physical (dimensions in mm) Microdrives

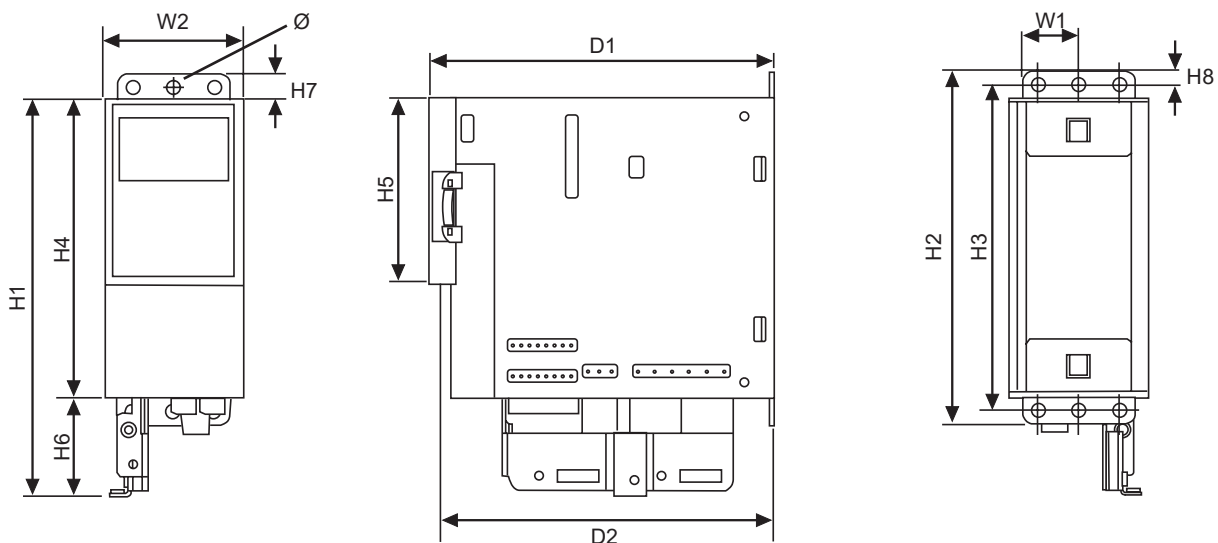

Type	Frame	W1	W2	H1	H2	H3	H4	H5	H6	H7	H8	D1	D2	Ø
NXL00015, & NXL00025, & NXL0002C1	MF2	30	60	172	152	140	130	80	42	11	6	150	144	6

Physical (dimensions in mm) Microdrives

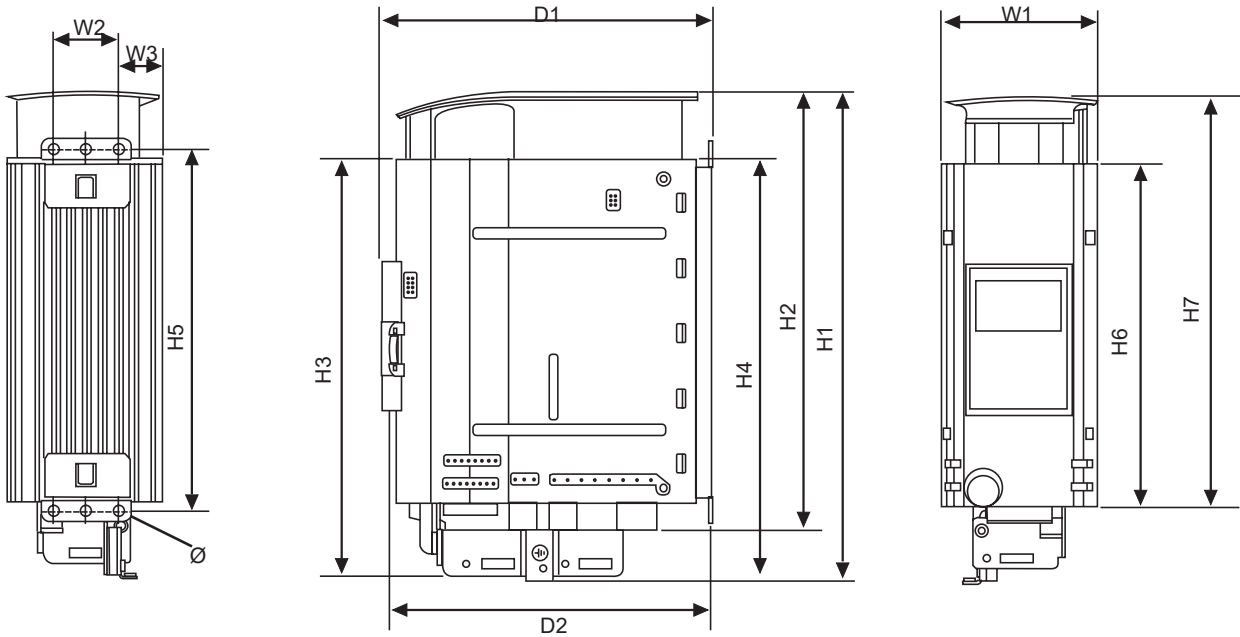

Type	Frame	W1	W2	W3	H1	H2	H3	H4	H5	H6	H7	D1	D2	Ø
NXL0003C1 to NXL0006C1	MF3	84	35	23	262	235	223	199	193	184	220	172	166	6

Ecodrives

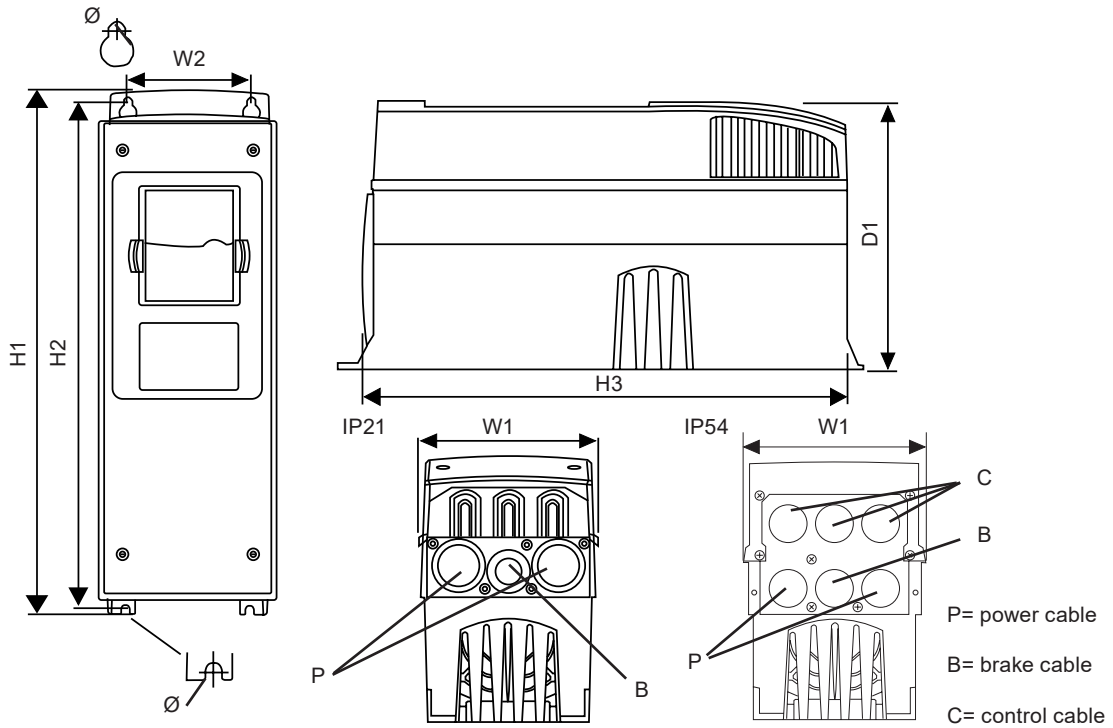

Type	Frame	W1	W2	H1	H2	H3	D1	Ø	P	B	C
NXLAA03xx to NXLAA12xx	MF4	128	100	327	313	292	190	7	2 x 20	1 x 20	1 x 25
NXLAA16xx to NXLAA23xx	MF5	144	100	419	406	391	214	7	2 x 25	1 x 25	1 x 25
NXLAA31xx									2 x 32	1 x 25	1 x 25
NXLAA38xx to NXLAA61xx	MF6	195	148	558	541	519	237	9	2 x 32	1 x 32	1 x 25

FUNCTIONALITY

The NXL range of variable speed drives provides both three phase to three phase (1 A to 61 A) and single phase to three phase (2 A to 6A) units. Of particular use in the HVAC environment, they enable fans and motors to regulate delivery of air and water in variable flow applications. Where flow rates may be reduced, motor energy can be significantly cut as the relationship between flow rate and power follows a cube law hence reducing flow by 20% reduces power by 50%. The drives also enable saving in installation costs; switchgear is eliminated, motor cables are reduced from 6 to 3 wires, power factor correction capacitors are not required, size and cost of cabling and fuses is minimised (as starting current is kept within nominal value).

The sensorless flux vector control gives dynamic precision over most of the speed range. A drive is provided with built-in control application, which can be set up from the control keypad. It has a slot for an optional I/O expansion board.

HARDWARE

The Trend NXL is an extremely slim, space-saving and easy-to-use frequency converter for the power range of 0.37 to 30 kW. The installation is flexible and easy using the mounting components shipped with the unit. Traditional back installation and side installation, suitable for very limited space, are available, as well as DIN rail mounting.

Easy programming and commissioning add to overall user-friendliness. The default control I/O of the Trend NXL includes the most common control inputs and outputs. For maximum compatibility, the connector numbers correspond to those of the Trend NX drives. Parameter setting is carried out in a familiar way, either via the control panel or by means of the PC tools for the NXL.

An optimal solution is available for most application needs. The modular design allows the choice of only the functions and features needed in a specific application. The control keypad is fitted as standard. The NXOPTAA board (3 x digital inputs, 1 x digital relay output, and 1 x digital open collector output) is fitted as standard in the I/O expansion slot of the Ecodrives; it can be fitted as an optional extra in the Microdrives. At the core of the NXL is sensorless vector control technology coupled with current measurements of all three output phases. Fieldbus control using RS485 Modbus is available as standard. The Trend NXL also incorporates PID control as standard, enhanced with a host of special features such as a sleep function.

Terminals for NXL0002C1 (MF2 single phase to three phase).

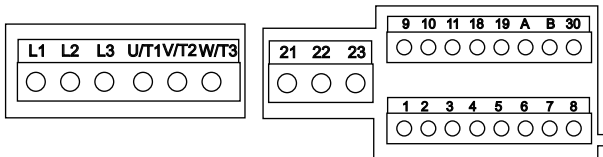

Terminals for NXL00015, NXL00025 (MF2 three phase to three phase).

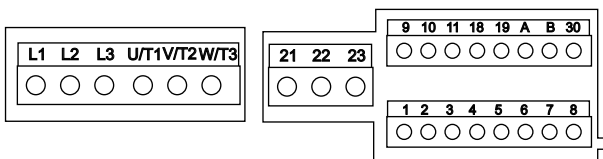

Terminals for NXLAA03xx to NXLAA61xx where xx = C2 or C5 (MF4 to MF6).

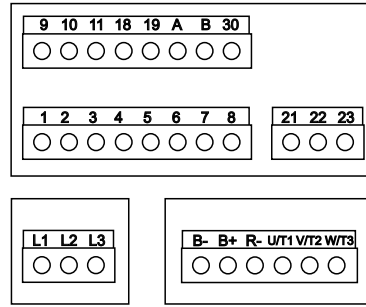

Terminals for NXL0003C1 to NXL0006C1 (MF3 single phase to three phase).

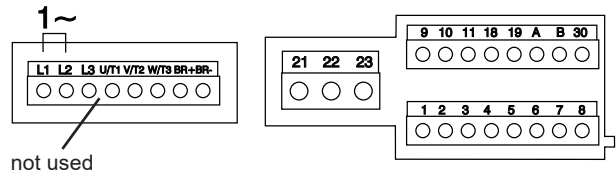

Standard I/O The unit provides basic I/O connections directly to suit common applications for NXL.

Typical connector for Multicontrol Application

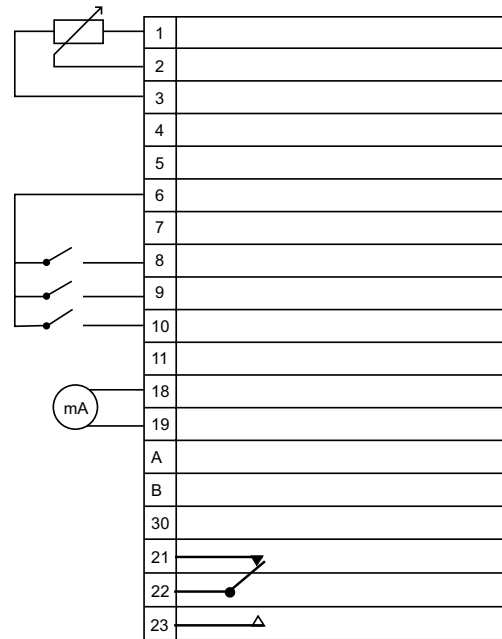

I/O Board NXOPTAA Additional control inputs and outputs are provided by the NXOPTAA I/O board (3 x digital inputs, 1 x digital relay output, and 1 x digital open collector output). It is fitted as standard to the Ecodrives and can be fitted as an optional extra to the Microdrives.

Terminals for I/O card NXOPTAA

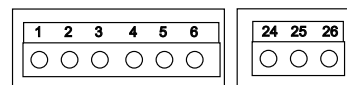

HARDWARE (continued)

Control Keypad: The control keypad is used for parameter setting, reading status data, and giving control commands. It is detachable and can be operated externally being connected via a cable to the frequency converter. A PC can be connected and used to control the frequency converter instead of the control keypad. (A 1.5 m, 9 way D type male to female extension cable is available, ACC/NXL/RS232PC. A door mounting kit including a 2m cable is available, NXLDRA.)



The Trend NXL control keypad features a seven-segment display with seven indicators for the Run status (RUN, READY, STOP, ALARM, FAULT) and three indicators for the control place (I/O term/ Keypad/BusComm). The control information, i.e. the number of menu, the displayed value and the numeric information are presented with numeric symbols.

The frequency converter is operable through the seven push-buttons of the control keypad. Furthermore, the buttons serve the purposes of parameter setting and value monitoring.

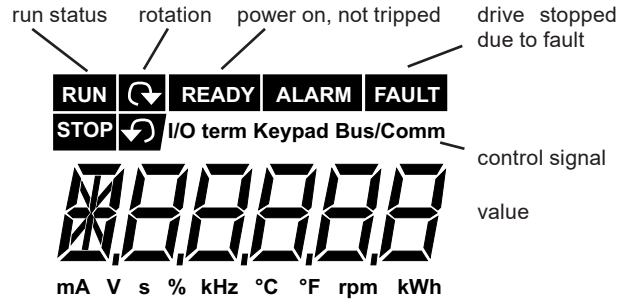

NXL Input and Output control terminals			
Terminal	Signal	Comment	
1	+10 Vref	Reference voltage	Maximum current 10 mA
2	AI1+ or DIN4	Analogue input, voltage or current	0 to 10 Vdc (Ri = 200 kohm) or 0 to 20mA (Ri = 250 ohm) selection with jumper block X4 can be programmed as DIN4
3	GND/AI1-	Analogue input common	Differential input if not connected to ground; Allows ±20V differential mode voltage to GND
4	AI2+	Analogue input, current	0 to 20mA (Ri=250 ohm)
5	GND/AI2-	Analogue input common	Differential input if not connected to ground; Allows ±20V differential mode voltage to GND
6	24 Vout	24V auxiliary voltage	±10%, maximum current 100 mA
7	GND	I/O ground	Ground for reference and controls
8	DIN1	Digital input 1	Ri = 5 kohm (min.)
9	DIN2	Digital input 2	
10	DIN3	Digital input 3	
11	GND	I/O ground	Ground for reference and controls
18	AO1+	Analogue signal (+output)	Output signal range: Current 0(4) to 20 mA, RL max 500 ohm or Voltage 0 to 10V, RL >1 kohm
19	AO1-	Analogue output common	
A	RS 485	Serial bus	Termination resistor
B	RS 485	Serial bus	Termination resistor
21	RO1/1	Relay output 1 NC	Maximum switching voltage 250Vac, 125Vdc Maximum switching current 8A/24Vdc, 8A/250Vac, 0.4A/125Vdc Min. switching load 5V/10 mA Relay output terminals are galvanically isolated from the I/O ground
22	RO1/2	Relay output 1 COM	
23	RO1/3	Relay output 1 NO	
30	+24V	24 V Aux input voltage	Control power supply backup
NXOPTAA Expander Input and Outputs terminals			
Terminal	Parameter	Comment	
X3			
1	+24V	Control voltage output; voltage for switches etc, max. 150 mA	
2	GND	Ground for controls, e.g for +24 V and DO	
3	DIN1	DIGIN:x.1	Digital input 1
4	DIN2	DIGIN:x.2	Digital input 2
5	DIN3	DIGIN:x.3	Digital input 3
6	DO1	DIOUT:x.1	Open collector output, 50 mA/48 V
X5			
24	RO1/NC	DIOUT:x.2	Relay output 1 Switching capacity 24Vdc/8A, 250Vac/8A, 125Vdc/0.4A
25	RO1/C		
26	RO1/NO		

HARDWARE (continued)

The keypad has seven buttons which are used for controlling the drive, setting parameters, and monitoring values.

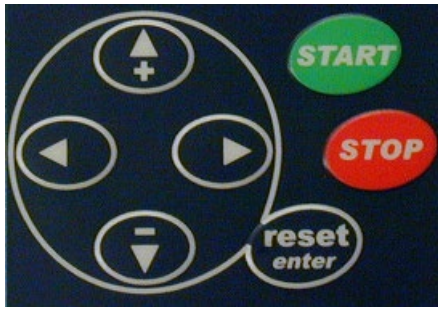

Button	Use
reset	resets active faults
enter	confirm selection or reset fault history (hold for 2 to 3 secs)
up +	browse up menu, edit values
down -	browse down menu, edit values
left	move backward in menu, left, exit edit
right	move forward in menu, right, enter edit
start	starts motor if keypad is control source
stop	stops motor if keypad is control source

The Keypad can be made the control source at any time by pressing the left arrow button for 5 secs. The keypad may then be used to start and stop the motor and to ramp its speed up and down by increasing or decreasing the output frequency shown on the display using the up and down keys. Pressing the left hand arrow button again for 5 secs will return the drive to remote control.

Note: The motor is stopped as the control changes from remote to local and vice versa.

The main menu consists of individual items M1 to E7 which are browsed using up and down buttons, the submenus under these menus are then browsed by left/right buttons.

M1 Monitoring: This enables the following signals to be monitored only.

Code	Signal Name	Units	Description
V1.1	Output frequency	Hz	Frequency to the motor
V1.2	Frequency reference	Hz	
V1.3	Motor speed	rpm	Calculated motor speed
V1.4	Motor current	A	Measured motor current
V1.5	Motor torque	%	Calculated torque/nominal torque of the unit
V1.6	Motor power	%	Calculated power/nominal power of the unit
V1.7	Motor voltage	V	Calculated motor voltage
V1.8	DC-link voltage	V	Measured DC-link voltage
V1.9	Unit temperature	°C	Heat sink temperature
V1.10	Voltage/ analogue input 1	V	AI1
V1.11	Current/ analogue input 2	mA	AI2
V1.12	Analogue output current	mA	AO1
V1.13	Analogue output current 1, expander board	mA	
V1.14	Analogue output current 2, expander board	mA	
V1.15	DIN1, DIN2, DIN3		Digital input statuses
V1.16	DIE1, DIE2, DIE3		I/O expander board: Digital input statuses
V1.17	RO1		Relay output 1 status
V1.18	ROE1, ROE2, ROE3		I/O exp. board: Relay output statuses
V1.19	DOE 1		I/O exp. board: Digital output 1 status
V1.20	PID reference	%	In percent of the maximum process reference
V1.21	PID actual value	%	In percent of the maximum actual value
V1.22	PID error value	%	In percent of the maximum error value
V1.23	PID output	%	In percent of the maximum output value
V1.24	Autochange outputs1, 2, 3		Used only in pump and fan control

HARDWARE (continued)

P2 Parameters: This enables the parameters to be edited. First the group of parameters is selected, then the individual parameter. The parameters below are for the basic group (P2.1), other groups are used and are described in the NXL Application Manual :

Code	Parameter	Default	Note
P2.1.1	Min. frequency	0.00 Hz	
P2.1.2	Max. frequency	50.00 Hz	
P2.1.3	Acceleration time	1.0 s	
P2.1.4	Deceleration time	1.0 s	
P2.1.5	Current limit	1.5 x Nominal A	
P2.1.6	Nominal motor voltage	400 V	
P2.1.7	Nominal motor frequency	50.00 Hz	
P2.1.8	Nominal motor speed	1440 rpm	
P2.1.9	Nominal motor current		
P2.1.10	Motor cos phi	0.85	
P2.1.11	Start function	0	0=Ramp 1= Flying start
P2.1.12	Stop function	0	1=Coasting 1=Ramp 2=Ramp+Run enable coast 3=Coast+Run enable ramp
P2.1.13	U/f optimisation	0	0=not used 1=Automatic torque boost
P2.1.14	I/O reference	0	0=AI1 1=AI2 2=Keypad 3=Fieldbus
P2.1.15	AI2 signal range	2	1=0mA to 20 mA 2=4mA to 20 mA
P2.16	Analogue output function	1	0=not used 1=Output freq. (0 to fmax) 2=Freq. reference (0 to fmax) 3=Motor speed (0 to nominal motor speed) 4=Output current (0 to nominal motor current) 5=Motor torque (0 to nominal motor torque) 6=Motor power (0 to nominal motor power) 7=Motor voltage (0 to nominal motor voltage) 8=DC-link volt (0 to 1000V) 9=PI controller ref value 10=PI controller actual value 11=PI controller error value 12=PI controller output
P2.1.17	DIN2 function	1	0=not used 1=Start Reverse (DIN1=Start forward) 2=Reverse (DIN1=Start) 3=Stop pulse (DIN1=Start pulse) 4=External fault, cc 5=External fault, oc 6=Run enable 7=Preset speed 2 8=Motor pot. UP (cc) 9=Disable PID (Direct freq. reference) 10=Interlock 1
P2.1.18	DIN3 function	6	0=not used 1=Reverse 2=External fault, cc 3=External fault, oc 4=Fault reset 5=Run enable 6=Preset speed 1 7=Preset speed 2 8=DC-braking command 9=Motor pot UP (cc) 10=Motor pot DOWN (cc) 11=Disable PID (Direct freq. reference) 12=PID Keypad ref. 2 selection 13=Interlock 2 14=Thermistor input
P2.1.19	Preset speed 1	10.00Hz	
P2.1.20	Preset speed 2	50.00 Hz	
P2.1.21	Automatic restart	0	0=Not used 1=Used
P2.1.22	Parameter conceal	1	0=All parameters visible 1=Only group P2.1 visible

HARDWARE (continued)

K3 Keypad Control: This enables changes to control source (I/O terminals, Keypad, or Bus/Comm), frequency reference, and motor direction of rotation.

Code	Parameter	Default	Note
P3.1	Control source	1	1=I/O terminals 2=Keypad 3=Fieldbus
P3.2	Keypad reference frequency	Hz	If keypad control
P3.3	Keypad direction	0	1 will reverse direction if keypad control
P3.4	Stop button	1	0=stop button enabled if keypad control 1=stop button always enabled
R3.5	PID reference	0	
R3.6	PID reference 2	0	Selected with digital inputs

F4 Active Faults: A critical fault which brought the drive to a halt will be displayed, and the history of up to 5 active faults can be browsed through. For each fault there are sub menu items recording day, time, and motor conditions at the time of the fault.

H5 Fault History: The fault history of up to 5 faults with submenus as for active faults.

S6 System: This enables the following system settings to be changed and monitored:

Code	Parameter	Sub-menu	Parameter	Description
S6.3	Copy parameters	P6.3.1	Parameter sets	Store or load two parameter sets or restore parameter defaults
S6.5	Security	P6.5.2	Parameter lock	Set 'locked' against parameters
S6.6	Keypad settings	P6.6.1	Default page	Default page displayed on keypad when timeout time expires or power is switched onto keypad (0=last page)
		P6.6.3	Timeout time	Timeout before default page is shown
S6.7	Hardware settings	P6.7.1	Internal brake resistor connection	Not available on frame sizes 3 to 6
		P6.7.2	Fan control	0= Continuous on frame sizes 2 and 3 1= Temperature on frame sizes 4, 5
		P6.7.3	HMI acknowledgement timeout	
		S6.7.4	HMI number of retries	
S6.8	System Information			
S6.8.1	Counters Menu	P6.8.1.1	Mwh counter	Total count of MWh, and days and hours passed for the NXL unit; resettable.
		P6.8.1.2	Operating days counter	
		P6.8.1.3	Operating hours counter	
S6.8.2	Trip Counters	P6.8.2.1	MWh trip counter	
		P6.8.2.2	Clear MWh trip counter	
		P6.8.2.3	Operating days trip counter	
		P6.8.2.4	Operating hours trip counter	
		P6.8.2.5	Clear operating time counter	
S6.8.3	Software Info	P6.8.3.1	Software package	
		P6.8.3.2	System SW version	
		P6.8.3.3	Firmware interface	
		P6.8.3.4	System load	
S6.8.4	Application info	P6.8.4.1.1	Application id	
		P6.8.4.1.2	Application version	
		P6.8.4.1.3	Firmware interface	
S6.8.5	Hardware info	P6.8.5.2	Unit voltage	
		P6.8.5.3	Brake chopper	
S6.8.6	Options	P6.8.6.1	NX opt	Status and programme version
S6.9	AI mode	P6.9.1	AIA1 mode	0=voltage input, 1=current input
		P6.9.2	AIA2 mode	0=voltage input, 1=current input
S6.10	Fieldbus parameters	P6.10.1	Communication status	
		P6.10.2	Fieldbus protocol	
		P6.10.3	Slave address	
		P6.10.4	Baud rate	
		P6.10.5	Stop bits	
		P6.10.6	Parity type	
		P6.10.7	Communication timeout	

E7 Expander Board: This enables the user to see whether the expander board is connected to the control board, and to monitor and edit parameters associated with the board.

FIRMWARE

APPLICATIONS

The Multicontrol Application for Vacon NXL uses direct frequency reference from the analogue input 1 as a default. However, a PID controller can be used e.g. in pump and fan applications, which offers versatile internal measuring and adjusting functions. This means that external devices are not necessary. When the drive is commissioned, the only visible parameter group is B2.1 (Basic parameters). The special parameters can be browsed and edited after changing the value of par. 2.1.22 (Parameter conceal).

The direct frequency reference can be used for the control without the PID controller and it can be selected from the analogue inputs, fieldbus, keypad, preset speeds or motor potentiometer.

The PID controller reference can be selected from the analogue inputs, fieldbus, PID keypad reference 1 or by enabling the PID keypad reference 2 via digital input. The PID controller actual value can be selected from the analogue inputs, fieldbus or the actual values of the motor. PID controller can also be used when the frequency converter is controlled via fieldbus or the control keypad.

- Digital inputs DIN2, DIN3, (DIN4) and optional dig. inputs DIE1, DIE2, DIE3 are freely programmable.
- Internal and optional digital/relay and analogue outputs are freely programmable.
- Analogue input 1 can be programmed as current input, voltage input or digital input DIN
- Additional functions:
- The PID controller can additionally be used from control places I/O, keypad and fieldbus
- Sleep function
- Actual value supervision function: fully programmable; off, warning, fault
- Programmable Start/Stop and Reverse signal logic
- Reference scaling
- 2 Preset speeds
- Analogue input range selection, signal scaling, inversion and filtering
- Frequency limit supervision
- Programmable start and stop functions
- DC-brake at start and stop
- Prohibit frequency area
- Programmable U/f curve and U/f optimisation
- Adjustable switching frequency
- Autorestart function after fault
- Protections and supervisions (all fully programmable; off, warning, fault):

SOFTWARE

Windows based PC utility tools are available for making the use of the Trend NXL as easy and convenient as possible. The software is intended for tasks such as commissioning, loading of various applications, and block programming. The built-in Help is available in all software. The minimum requirement for using the software is a PC and the ACC/NXL/RS232PC serial cable, to be connected to the RS232C terminal behind the control panel. A standard RS232 cable should not be used.

NCDrive: NCDrive is an easy-to-use commissioning software for the control of the NXL. NCDrive allows you to load parameters from the drive, change them, save them in a file or load them back to the drive, print the parameters on paper or to a file, set references, start and stop the motor, monitor signals on a graphical display and to monitor the actual values. You can also compare sets of drive parameters in order to identify changed values.

In the PARAMETER window you can view, set and store parameters as well as compare them to user-stored or default values so that changed values are easily identified.

In the MONITOR window you can monitor a total of eight freely user-specified variables simultaneously.

NCDrive requires a PC equipped with a Pentium II processor, 32 MB free RAM, 10 MB free disk space and Windows 95/98 or 2000.

NCLoad: This is a tool for loading the following software to the drive:

- system software (the operating system)
- application software
- option card software

NCLoad is mainly intended for use by variable speed drive professionals and service personnel. In addition to the system software, NCLoad is also suitable for loading custom-made applications to the drive. The minimum hardware requirements are those of NCDrive.

NC1131-3: A graphical design tool for custom applications using block diagrams, ladder logic, or structured text to define the application

INSTALLATION

The Trend NXL drive must be installed in a vertical position. It can be mounted on a wall or in an enclosure using four screws or bolts. The cooling method for NXL00015, NXL00025, and NXL0002C1 is convection type. Forced air cooling is used for NXL0003C1 to NXL0006C1 and NXLAA03 (C2 or C5) to NXLAA061(C2 or C5). The cooling airflow to the drive must not be blocked in any way, recirculation of air inside the enclosure should be avoided.

Enough free space should be left above and below the frequency converter to ensure sufficient circulation and cooling. The following table gives the required clearance dimensions.

Overload protection of the supply cable should be considered (e.g. fuses). The use of shielded motor cables is recommended; they should be routed as far away from other cables as possible, and cross other cables at right angles. The motor cable shield should be grounded at both the NXL drive and at the motor.

Frame	Type	A (mm)	B (mm)	C (mm)	D (mm)
MF2	NXL00015, NXL00025, NXL0002C1	10	10	100	50
MF3	NXL0003C1 to NXL0006C1	10	10	100	50
MF4	NXLAA03C2 to NXLAA12C2 NXLAA03C5 to NXLAA12C5	20	20	100	50
MF5	NXLAA16C2 to NXLAA31C2 NXLAA16C5 to NXLAA31C5	20	20	120	60
MF6	NXLAA38C2 to NXLAA61C2 NXLAA38C5 to NXLAA61C5	30	20	160	80

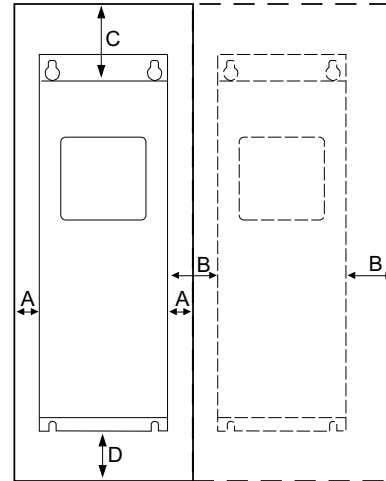

The installation involves:

- mount the controller in position
- connect mains cable
- connect motor cable
- check mains and motor cable insulation
- connect control cable
- check quality and quantity of cooling air
- check inside of drive for condensation
- set up links on basic board
- check all start/stop switches connected to I/O are at stop
- switch on power to drive
- configure the drive (e.g. using the keypad)
- perform run test without motor
- commission with motor connected

This installation procedure, is covered by the Trend NXL Installation Instructions, (TG200620), and NXL Ecodrives Quick Guide (TG200975).

DISPOSAL

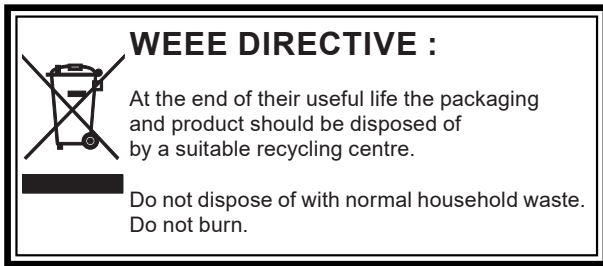

ORDER CODES

Microdrives (Three phase 380 to 500 Vac to three phase)

NXL00015 :Rated load overload $I_L = 1.9$ A, IP20, frame size MF2
NXL00025 :Rated load overload $I_L = 2.4$ A, IP20, frame size MF2

These units have no EMC emissions protection and no internal brake chopper. An external filter is available (see below).

Ecodrives (Three phase 380 to 520 Vac to three phase)

NXL [current] [IP]

Option	Value	Description	
IP	IP21	IP21	
	IP54	IP54	
Current		Rated Overload	Frame size
	AA03	3.3	MF4
	AA04	4.3	MF4
	AA05	5.6	MF4
	AA07	7.6	MF4
	AA09	9	MF4
	AA12	12	MF5
	AA16	16	MF5
	AA23	23	MF5
	AA31	31	MF5
	AA38	38	MF6
	AA45	45	MF6
AA61	61	MF6	

e.g. **NXLAA16C2** Rated load overload $I_L = 16$ A, IP21, frame size MF5

These units have an internal RF1 filter and internal brake chopper. The additional I/O board, NXOPTAA, is fitted as standard.

Microdrives (Single phase 208 to 240 Vac to three phase)

NXL0002C1 :Rated load overload $I_L = 2.4$ A, IP20, frame size MF2
NXL0003C1 :Rated load overload $I_L = 3.7$ A, IP20, frame size MF3
NXL0004C1 :Rated load overload $I_L = 4.8$ A, IP20, frame size MF3
NXL0006C1 :Rated load overload $I_L = 6.6$ A, IP20, frame size MF3

These units have no EMC emissions protection and no internal brake chopper. An external filter is available (see below).

Note: Neither the NXNI, IQ system current loop Lan interface, or the NXIP, the Ethernet network interface are compatible with the NXL range of Variable Speed Drives (they are compatible with the NX range).

ACC/NXL/FILTER/FR2-3 :Filter for frame sizes MF2 or MF3
ACC/NXL/RS232PC :NXL to PC cable (also requires use of RS232 adaptor below)
ACC/RS232/ADAPTOR :NXL RS232 adaptor for use with NXL to PC cable
NXLDR A :Door mounting kit for control keypad including 2 m cable
NXOPTAA :I/O expander card with 3x Digital Input, 1x Digital Output (open collector) and 1x Digital Output (changeover relay). Fitted as standard to the Ecodrives and available as an optional extra for the Microdrives.

Additionally software tools are available:

NCDrive :Commissioning software tool
NCLoad :Tool for loading software to drive
NC1131-3 :Tool for creating customised applications

SPECIFICATIONS

ELECTRICAL

Supply voltage	
Three phase units	:380 to 500 Vac -15% +10% 3 phase, 45 to 66 Hz
Single phase units	:208 to 240 Vac -15% +10% 1 phase, 45 to 66 Hz
Motor voltage	:0 to supply voltage
Motor current	
Rated output	: I_L , 1.9 A to 61 A dependent on option (continuous current under low overload, 10% for 1 minute every 10 minutes, 150% starting torque requirement, 40 °C ambient temperature e.g. fans, pumps)
High overload	: I_H , see table (continuous current under high overload, 50% for 1 minute every 10 minutes, 200% starting torque requirement, 50 °C ambient temperature e.g. cranes, hoists, lifts)
Starting Current	: $2xI_H$, (maximum current required for 2 secs every 20 secs if output frequency <30 Hz, and heat sink temperature <+60 °C)
Output frequency	:0 to 320 Hz
Frequency resolution	:0.01 Hz
Control method	:Frequency control, Open loop sensorless vector control
Switching frequency	:1 to 16 kHz (factory default 6 kHz)
Frequency reference	
Analogue input	:Resolution 0.1% (10 bit), accuracy $\pm 1\%$
Keypad reference	:Resolution 0.01 Hz
Field weakening point	:30 to 320 Hz
Acceleration time	:0.1 to 3000 secs
Deceleration time	:0.1 to 3000 secs
Braking torque	
DC brake	:30% TN (nominal torque) without brake option

Order Code	Motor Shaft Power P(kW)	
	380 Vac	
	Low 40 deg C P(kW)	High 50 deg C P(kW)
NXL00015	0.55	0.37
NXL00025	0.75	0.55
NXLAA03C2/C5	1.1	0.75
NX AA04C2/C5	1.5	1.1
NXLAA05C2/C5	2.2	1.5
NXLAA07C2/C5	3.0	2.2
NXLAA09C2/C5	4.0	3.0
NXLAA12C2/C5	5.5	4.0
NXLAA16C2/C5	7.5	5.5
NXLAA23C2/C5	11	7.5
NXLAA31C2/C5	15	11
NXLAA38C2/C5	18.5	15
NXLAA45C2/C5	22	18.5
NXLAA61C2/C5	30	22
	208 to 240 Vac	
NXL0002C1	0.37	0.25
NXL0003C1	0.75	0.55
NXL0004C1	1.1	0.75
NXL0006C1	1.5	1.2

Order Code	Loadability			
	Low		High	
	Rated Continuous Current I_L (A)	10% overload current (A)	Rated Continuous Current I_H (A)	50% Overload Current I_S (A)
NXL00015	1.9	2.1	1.3	2
NXL00025	2.4	2.6	1.9	2.9
NXLAA03C2/C5	3.3	3.6	2.2	3.3
NXLAA04C2/C5	4.3	4.7	3.3	5
NXLAA05C2/C5	5.6	5.9	4.3	6.5
NXLAA07C2/C5	7.6	8.4	5.6	8.4
NXLAA09C2/C5	9	9.9	7.6	11.4
NXLAA12C2/C5	12	13.2	9	13.5
NXLAA16C2/C5	16	17.6	12	18
NXLAA23C2/C5	23	25.3	16	24
NXLAA31C2/C5	31	34	23	35
NXLAA38C2/C5	38	42	31	47
NXLAA45C2/C5	46	51	38	57
NXLAA61C2/C5	61	67	46	69
NXL0002C1	2.4	2.6	1.7	2.6
NXL0003C1	3.7	4.1	2.8	4.2
NXL0004C1	4.8	5.3	3.7	5.6
NXL0006C1	6.6	7.3	4.8	7.2

Protective Functions

Overcurrent	:Trip limit 4.0 x I_H instantaneously
Overvoltage protection	:911 Vdc
Undervoltage protection	:333 Vdc
Earth fault protection	:In case of earth fault in motor or motor cable, only the frequency converter is protected
Other	:Unit overtemperature protection, motor overload protection, motor stall protection, motor underload protection, short circuit protection of +24 V and +10 V reference voltages

Inputs and Outputs

Analogue voltage input	:0 to +10 V, $R_{in} = 200 \text{ k}\Omega$, single ended. Resolution 12 bit, accuracy $\pm 1\%$
Analogue current input	:0 (4) to 20 mA, $R_{in} = 250 \Omega$, differential
Digital inputs	:3 off (Ecodrives have 6). Positive or negative logic, 18 to 24 Vdc
Auxiliary voltage out	:+24 V $\pm 15\%$, 100 mA max.
Reference voltage out	:+10 V, +3% 10 mA max.
Analogue output	:1 off. 0(4) to 20 mA, $R_L < 500\Omega$, resolution 16 bit, accuracy $\pm 1\%$
Digital Output (relay)	:1 off (Ecodrives have 2). Programmable changeover relay max. switching capacity: 24 Vdc/8 A, 250 Vac/8 A, 125 Vdc/0.4 A.
Digital Output (open collector)	:1 off (Ecodrives only). 50 mA, 48 V

MECHANICAL

Order Code	Weight (kg)
NXL00015	1.0
NXL00025	1.0
NXLAA03C2/C5	5
NX AA04C2/C5	5
NXLAA05C2/C5	5
NXLAA07C2/C5	5
NXLAA09C2/C5	5
NXLAA12C2/C5	5
NXLAA16C2/C5	8.1
NXLAA23C2/C5	8.1
NXLAA31C2/C5	8.1
NXLAA38C2/C5	18.5
NXLAA45C2/C5	18.5
NXLAA61C2/C5	18.5
NXL0002C1	1.0
NXL0003C1	1.9
NXL0004C1	1.9
NXL0006C1	2.0

ENVIRONMENTAL

Operating Temperature: -10 °C (no frost) to +50 °C: (IH)
 -10 °C (no frost) to +40 °C: (IL)
 Storage temperature : -40 °C to +70 °C
 Relative humidity : 0 to 95 %RH non-condensing,
 non-corrosive, no dripping water

Air quality
 chemical vapours : IEC721-3-3, unit in operation class 3C2
 mechanical particles : IEC721-3-3, unit in operation class 3S2

Altitude : 100% load capacity (no derating) up to 1000 m. 1% derating for each 100 m above 1000 m (max. 3000 m)

Vibration : EN50178 and EN60068-2-6
 Shock : EN50178 IEC 68-2-27. UPS drop test (for applicable UPS weights)

Enclosure class : IP20, IP21, IP54 (see codes p9)
 EMC Immunity : EN50082-1, -2, EN61800-3
 EMC Emissions
 MF2, MF3 : EMC level N. Can have external filter to achieve level H.
 MF4 to MF6 : EMC level H: EN61800-3(1996) + A11 (2000) (1st environment, restricted use, 2nd environment), EN61000-4.

Safety : Fulfils EN50178, EN60204-1, CE, UL, cUL, FI, GOST R , IEC 61800-5 (check nameplate for details)

Please send any comments about this or any other Trend technical publication to techpubs@trendcontrols.com

© 2018 Honeywell Products and Solutions SARL, Connected Building Division. All rights reserved. Manufactured for and on behalf of the Connected Building Division of Honeywell Products and Solutions SARL, Z.A. La Pièce, 16, 1180 Rolle, Switzerland by its Authorized Representative, Trend Control Systems Limited.

Trend Control Systems Limited reserves the right to revise this publication from time to time and make changes to the content hereof without obligation to notify any person of such revisions or changes.

Trend Control Systems Limited

St. Mark's Court, North Street, Horsham, West Sussex, RH12 1BW, UK. Tel: +44 (0)1403 211888, www.trendcontrols.com