

PS300

Pump control valve

Product specification sheet

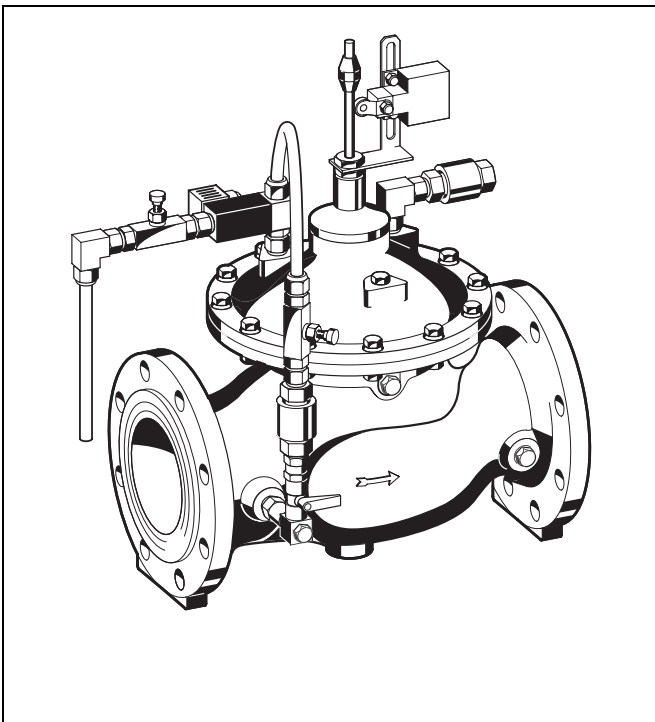

Construction

The pump control valve comprises:

- Housing with PN16 flanges per ISO7005-2, EN1092-2
- Magnetic solenoid valve
- Check valve
- End switch
- Fine regulation valve
- Control circuit with ball valves on inlet and outlet
- Control circuit with integral rinsable filter insert

Materials

- Ductile iron housing, cover plate and diaphragm plate (ISO 1083), powder coated
- Red bronze/stainless steel regulating cone
- Stainless steel pressure spring and control rod
- Fibre-reinforced NBR diaphragm
- NBR and EPDM seals
- Stainless steel valve seat
- High quality synthetic material control circuits
- Brass compression fittings
- Brass magnetic valve and check valve housings
- Stainless steel filter insert

Application

Pump control valves of this type are used as a protection valve in pressure boosting systems to provide a water hammer free shut-down and start-up of pumps.

Special Features

- High flow capacity
- Light weight
- Powder coated inside and outside - Powder used is physiologically and toxicologically safe
- Integral control circuit and ball valves

Range of Application

Medium	Water
Operating pressure	Max. 16 bar
Magnetic solenoid pilot valve	24 V AC, IP 65 230 V/50 Hz on request

Technical Data

Operating temperature	Max. 80 °C
Nominal pressure	PN 16 PN 25 on request
Minimum pressure	0.7 bar
Connection size	DN 50 - 450

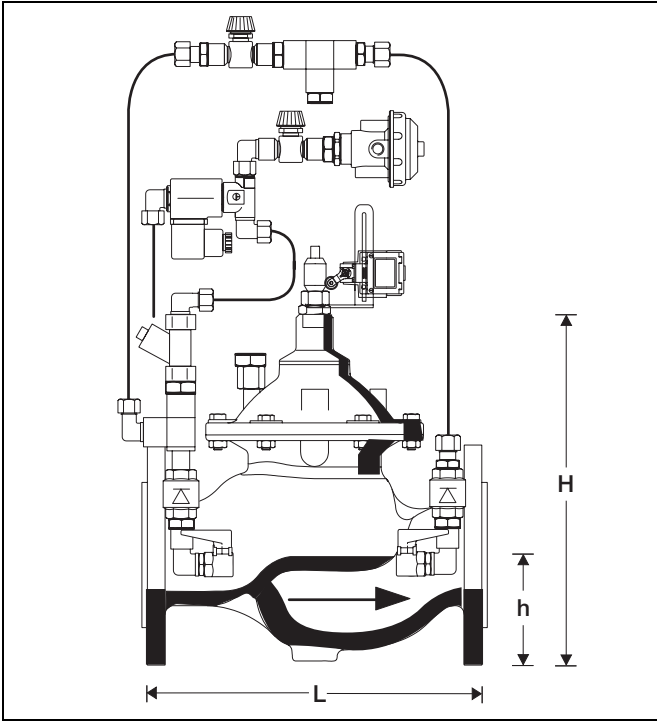

Method of Operation

Negative pressures or pressure shocks can occur in pressurised pipelines when pumps shut off. The negative pressure or excess pressure becomes ever greater as the length of the pipework after the pump is increased.

Pump control valves of this type gradually reduce the pump to zero demand by slowly closing the valve before the pump is shut off. Pump shutoff occurs when the electrical end switch on the valve is operated.

Options

PS300- ... A = Housing with flange, PN 16, ISO 7005, EN 1092-2

PS300- ... B = Housing with flange, PN 16, Magnetic solenoid pilot valve 230 V/50 Hz on request

PS300- ... Z = PN 25, on request

Connection size

Connection size	DN	50	65	80	100	150	200	250	300	350	400	450
Weight	approx. kg	14	15	24	39	82	159	247	407	512	824	947
Dimensions	(mm)											
	L	230	292	310	350	480	600	730	850	980	1100	1200
	H	235	294	400	433	558	650	823	944	990	1250	1250
	h	83	93	100	110	143	173	205	230	260	290	310
Flow rate (Q _{max}) in m ³ /h - V=5.5 m/s		40	40	90	160	350	480	970	1400	1900	2500	3150
k _{vs} -value	m ³ /h	43	43	103	167	407	676	1160	1600	1600	3300	3300

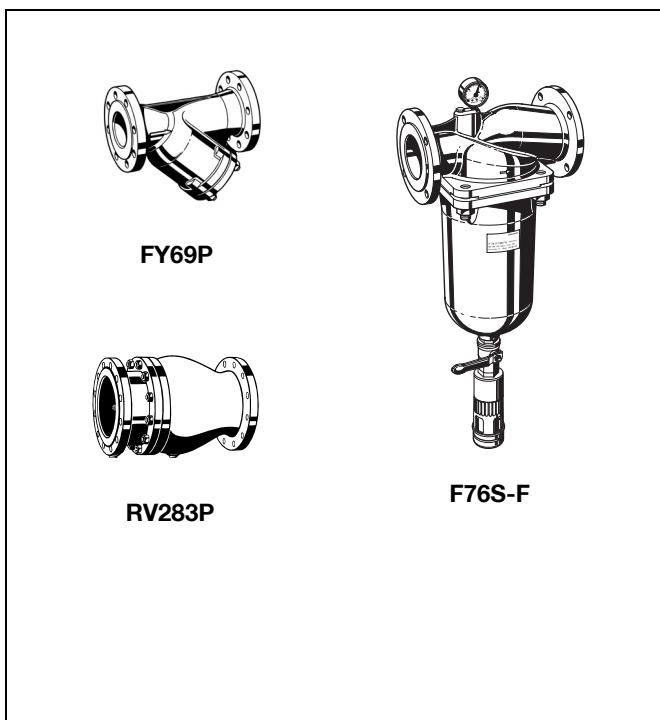

Accessories

FY69P Strainer

With double mesh, grey cast iron housing, powder coated inside and outside.

A = Mesh size approximately 0.5 mm

F76S-F Reverse-rinsing filter

Red bronze housing and filter bowl. Available in sizes DN 65 to DN 100, with filter mesh sizes 100 µm or 200 µm

RV283P Check valve

Grey cast iron housing, powder coated inside and outside. DIN/DVGW tested in compulsory test sizes DN 65, DN 80 and DN 100

Installation Example

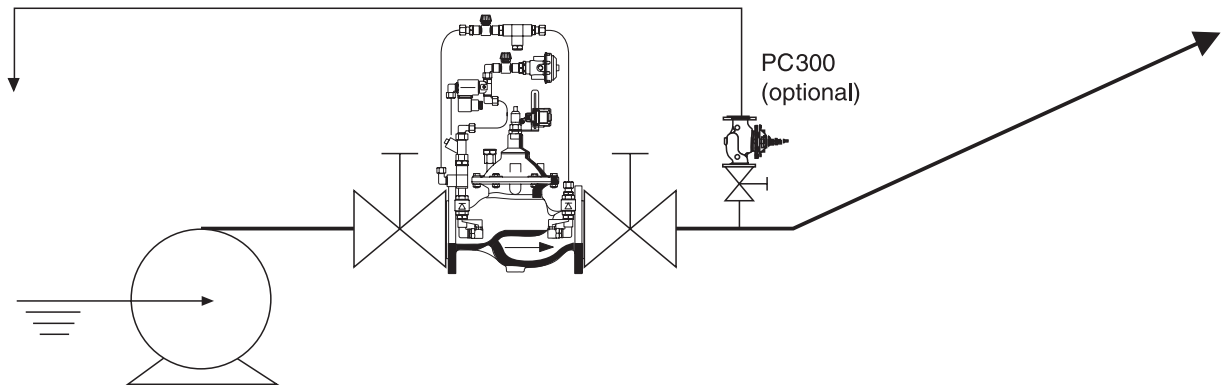

Installation Guidelines

- Install shutoff valves on both sides of the pressure sustaining valves
- Install strainer upstream of filling valve
 - Protects against damage from coarse dirt
- Note flow direction (indicated by arrow)
- Ensure good access
 - Simplifies maintenance and inspection
- The opening period is dependent on the length of the supply pipework and should be increased if this pipework is extremely long
- The valve of this type cannot prevent excess pressure such as may be caused by a sudden electrical power failure
 - For this purpose a PC 300 surge anticipating valve should be fitted as well
- Install connectors for removal and refitting for maintenance

Typical Applications

Pump control valves of this type, within the limit of their specification, are suitable for use for water supply systems and for commercial and industrial installations.

The following are some typical applications:

- Water pressure shock load protection in pressure boosting systems in mining
- Dedicated water supplies to industrial users

Flow Diagram

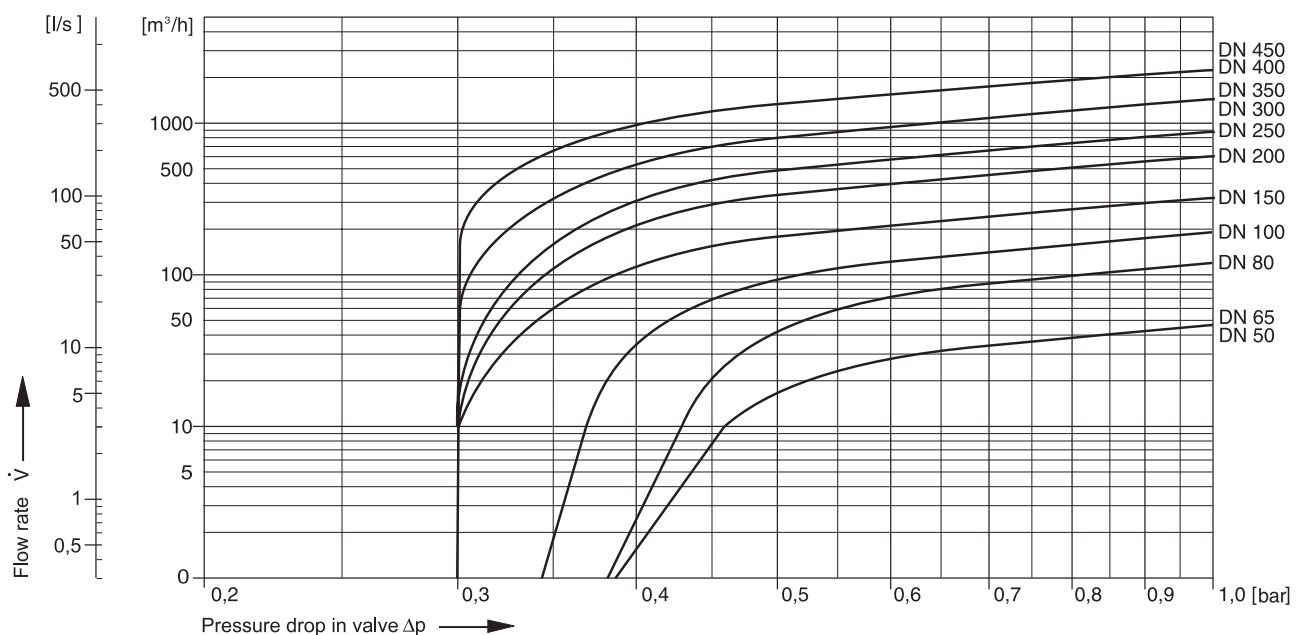

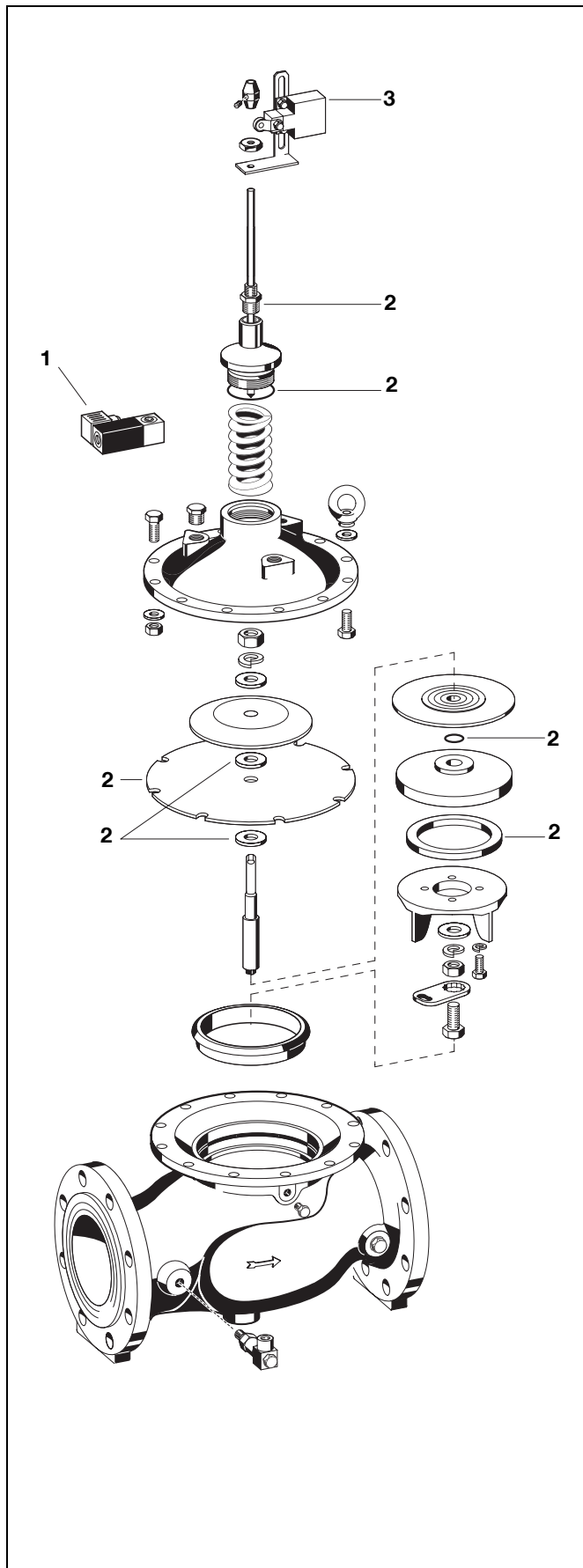

Spare Parts

Pump control valve PS300, from 2002 onwards

No.	Description	Dimension	Part No.
1	Replacement magnetic solenoid valve Normally closed with electrical supply off 24 V	DN 50 - 450	30-NC 0903763
2	Set of seals	DN 50 DN 65 DN 80 DN 100 DN 150 DN 200 DN 250 DN 300 DN 350 DN 400 DN 450	0903750 0903751 0903752 0903753 0903754 0903755 0903756 0903757 0903758 0903759 0903760
3	End switch	DN 50 - 450	0903764

Automation and Control Solutions

Honeywell GmbH
 Hardhofweg
 D-74821 Mosbach
 Phone: (49) 6261 810
 Fax: (49) 6261 81309
<http://europe.hbc.honeywell.com>
www.honeywell.com

Manufactured for and on behalf of the
 Environmental and Combustion Controls Division
 of Honeywell Technologies Sàrl, Z.A. La Pièce 16,
 1180 Rolle, Switzerland by its Authorised Repre-
 sentative Honeywell GmbH

EN0H-1333GE23 R0610
 Subject to change without notice
 © 2010 Honeywell GmbH

Honeywell