

## MV300

### Magnetic solenoid valve

#### Product specification sheet

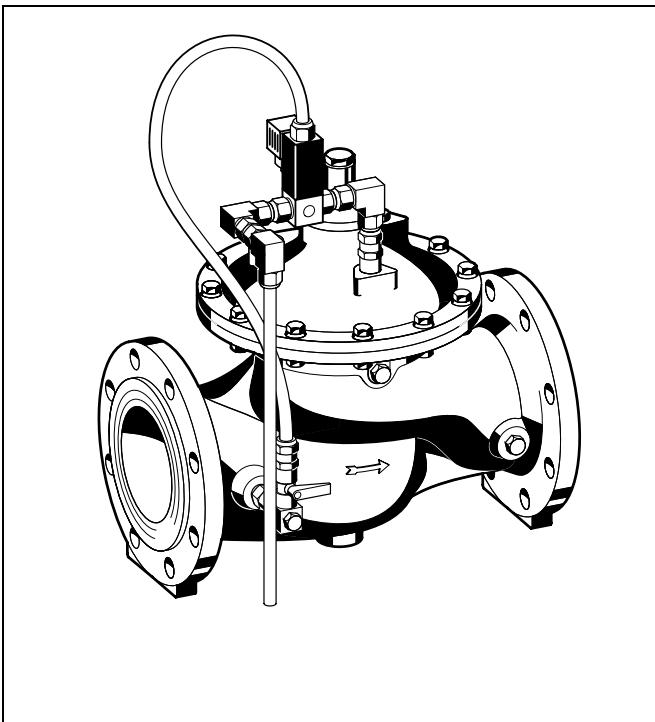

#### Construction

The magnetic solenoid valve comprises:

- Housing with PN16 flanges per ISO7005-2, EN1092-2
- Magnetic solenoid pilot valve
- Control circuit with ball valves
- Control circuit with integral rinsable filter insert

#### Materials

- Ductile iron housing, cover plate and diaphragm plate (ISO 1083), powder coated
- Red bronze/stainless steel regulating cone
- Stainless steel pressure spring and control rod
- Fibre-reinforced NBR diaphragm
- NBR and EPDM seals
- Stainless steel valve seat
- High quality synthetic material control circuits
- Brass compression fittings
- Brass magnetic solenoid pilot valve housing
- Stainless steel filter insert

#### Application

Magnetic solenoid valves of this type are mainly used as shutoff valves. They are controlled by the integral magnetic solenoid operated valve.

Their compact design makes them ideally suited where space is limited, for example in ducts. Within the scope of their specification they can be used on industrial and commercial applications.

#### Special Features

- High flow capacity
- Light weight
- Fitting of impulse link pipework is not necessary
- Pilot valves are in two versions - normally closed (standard) and normally open (to special order)
- Powder coated inside and outside - Powder used is physiologically and toxicologically safe
- Integral control circuit and ball valves

#### Range of Application

Medium	Water
Operating pressure	Max. 16 bar
Magnetic solenoid pilot valve	Version A = Normally closed 230 V/50 Hz, IP 65
	Version AA = Normally open 230 V/50 Hz, IP 65
	Version B = Normally closed 24 V/50 Hz, IP 65
	Version BB = Normally open 24 V/50 Hz, IP 65

#### Technical Data

Operating temperature	Max. 80 °C
Nominal pressure	PN 16 PN 25 on request
Minimum pressure	0.7 bar
Connection size	DN 50 - 450

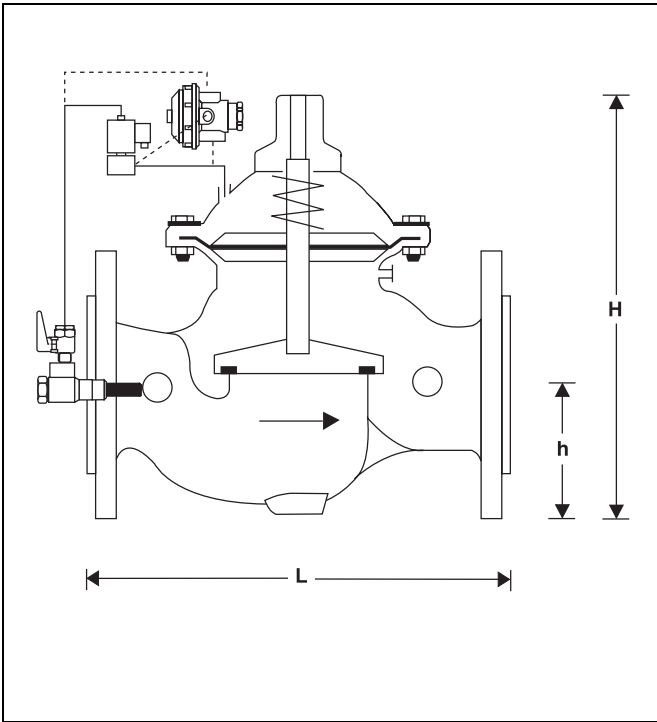

**Method of Operation**

At zero pressure the valve is closed. When opened to flow, water enters the inlet area and the rising pressure opens the valve so that water flows into the outlet area. The magnetic solenoid pilot valve is normally closed when the electrical supply is off, so the pressure from the inlet increases the pressure above the diaphragm. The pressure above the diaphragm built up in this way then becomes significantly greater than the pressure on the valve plate (which is also created by the inlet pressure), so that the valve then closes. As soon as the magnetic solenoid pilot valve opens, the pressure in the diaphragm chamber falls to atmospheric pressure and the pressure then exerted on the valve plate surface causes the valve to begin to open.

**Options**

- MV300- ... A = Housing with flange PN 16, ISO 2084, Magnetic solenoid pilot valve 230 V / 50 Hz closed when electrical supply off
- MV300- ... AA = Housing with flange PN 16, ISO 2084, Magnetic solenoid pilot valve 230 V / 50 Hz open when electrical supply off
- MV300- ... B = Housing with flange PN 16, ISO 2084, Magnetic solenoid pilot valve 24 V / 50 Hz closed when electrical supply off
- MV300- ... BB = Housing with flange PN 16, ISO 2084, Magnetic solenoid pilot valve 24 V / 50 Hz open when electrical supply off
- MV300- ... Z = PN 25, on request, closed when electrical supply off

Connection size

Connection size	DN	50	65	80	100	150	200	250	300	350	400	450
Weight	approx. kg	14	15	24	39	82	159	247	407	512	824	947
Dimensions	(mm)											
	L	230	292	310	350	480	600	730	850	980	1100	1200
	H	235	294	400	433	558	650	823	944	990	1250	1250
	h	83	93	100	110	143	173	205	230	260	290	310
Flow rate (Q <sub>max</sub> ) in m <sup>3</sup> /h - V=5.5 m/s		40	40	90	160	350	480	970	1400	1900	2500	3150
k <sub>vs</sub> -value	m <sup>3</sup> /h	43	43	103	167	407	676	1160	1600	1600	3300	3300

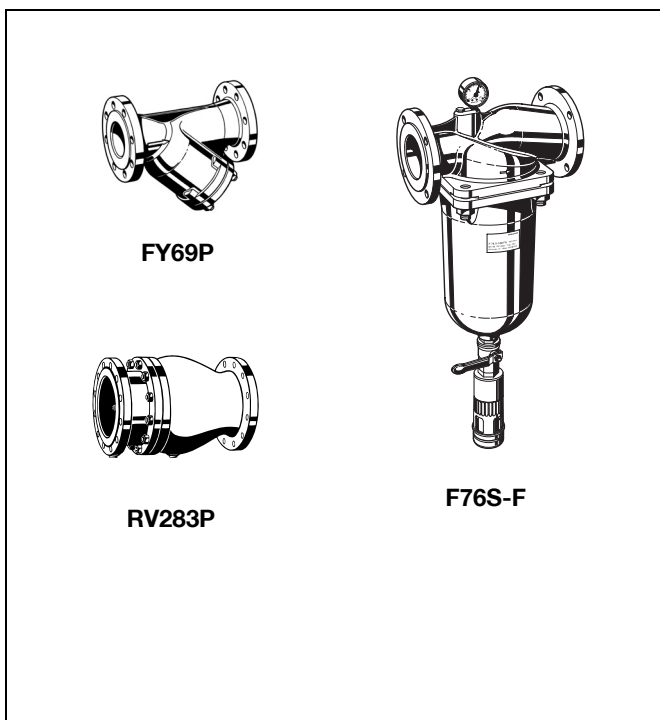

**Accessories**

**FY69P Strainer**

With double mesh, grey cast iron housing, powder coated inside and outside.  
A = Mesh size approximately 0.5 mm

**F76S-F Reverse-rinsing filter**

Red bronze housing and filter bowl. Available in sizes DN 65 to DN 100, with filter mesh sizes 100 µm or 200 µm

**RV283P Check valve**

Grey cast iron housing, powder coated inside and outside. DIN/DVGW tested in compulsory test sizes DN 65, DN 80 and DN 100

**Installation Example**

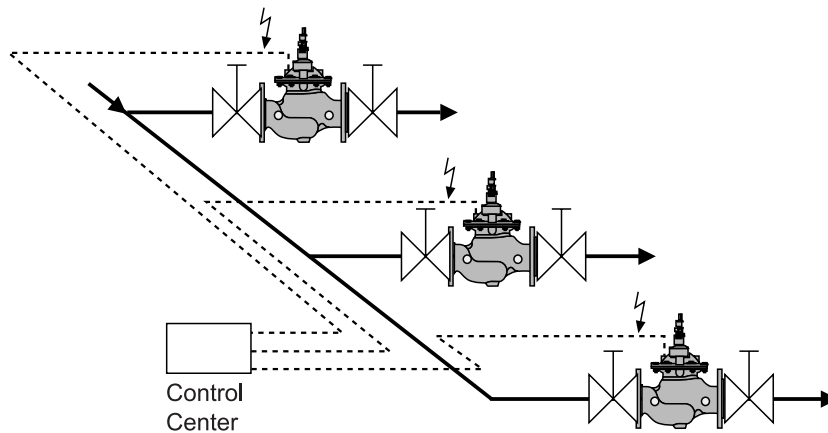

**Installation Guidelines**

- Install shutoff valves on both sides of the pressure sustaining valves
- Install strainer upstream of filling valve
  - o Protects against damage from coarse dirt
- Note flow direction (indicated by arrow)
- Ensure good access
  - o Simplifies maintenance and inspection
- Install connectors for removal and refitting for maintenance

**Typical Applications**

Magnetic solenoid valves of this type, within the limits of their specification, are suitable for installation in water supply systems, in buildings and in commercial and industrial installations.

The following are some typical applications:

- Potable water supply
- Firefighting systems - sprinkler installations
- Watering systems in market gardens and in agriculture
- Mining applications
- Gravel pits, concrete mixing plants etc.

**Flow Diagram**

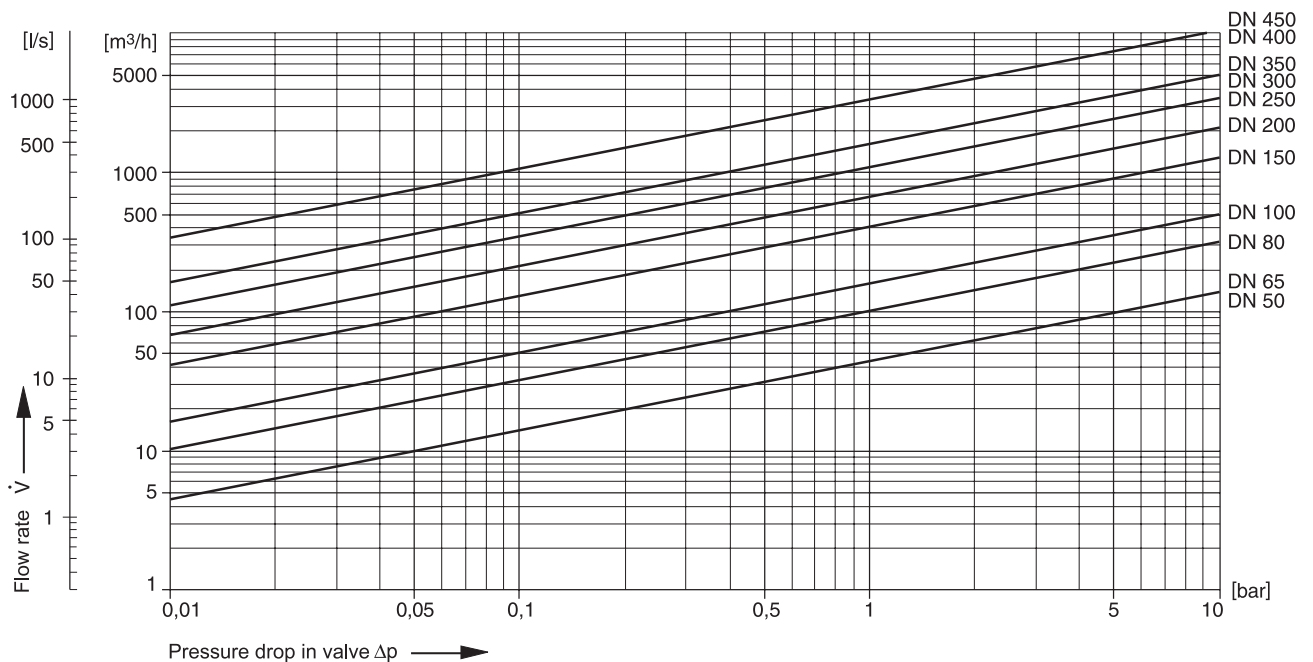

EN0H-1330GE23 R0610 • Subject to change

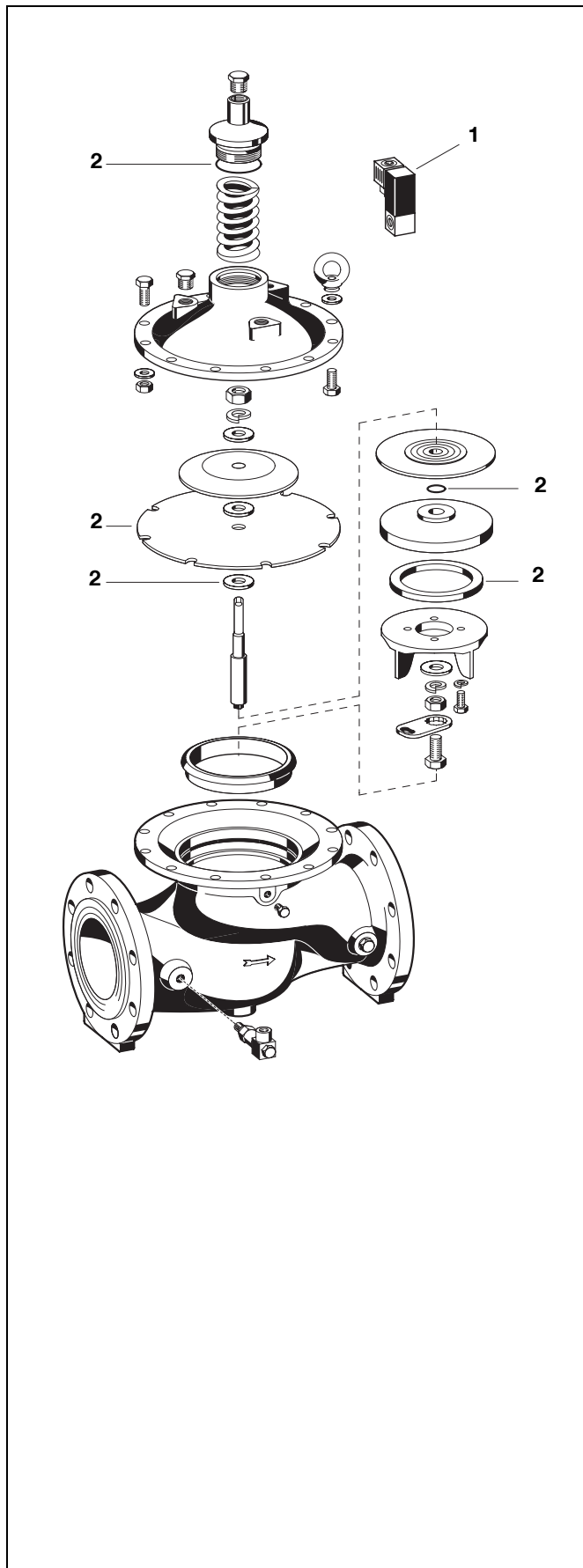

**Spare Parts**

**Magnetic solenoid valve MV300, from 2002 onwards**

No.	Description	Dimension	Part No.
1	Replacement magnetic solenoid valve	230 V/50 Hz	0903761
		24 V/50 Hz	0903762
2	Set of seals	DN 50	0903750
		DN 65	0903751
		DN 80	0903752
		DN 100	0903753
		DN 150	0903754
		DN 200	0903755
		DN 250	0903756
		DN 300	0903757
		DN 350	0903758
		DN 400	0903759
	DN 450	0903760	

**Automation and Control Solutions**

Honeywell GmbH  
 Hardhofweg  
 D-74821 Mosbach  
 Phone: (49) 6261 810  
 Fax: (49) 6261 81309  
<http://europe.hbc.honeywell.com>  
[www.honeywell.com](http://www.honeywell.com)

Manufactured for and on behalf of the  
 Environmental and Combustion Controls Division  
 of Honeywell Technologies Sàrl, Z.A. La Pièce 16,  
 1180 Rolle, Switzerland by its Authorised Representative Honeywell GmbH

EN0H-1330GE23 R0610  
 Subject to change without notice  
 © 2010 Honeywell GmbH

**Honeywell**