

HS74CA

Fully automatic combination water supply unit with automatic reverse rinsing actuator

Product specification sheet

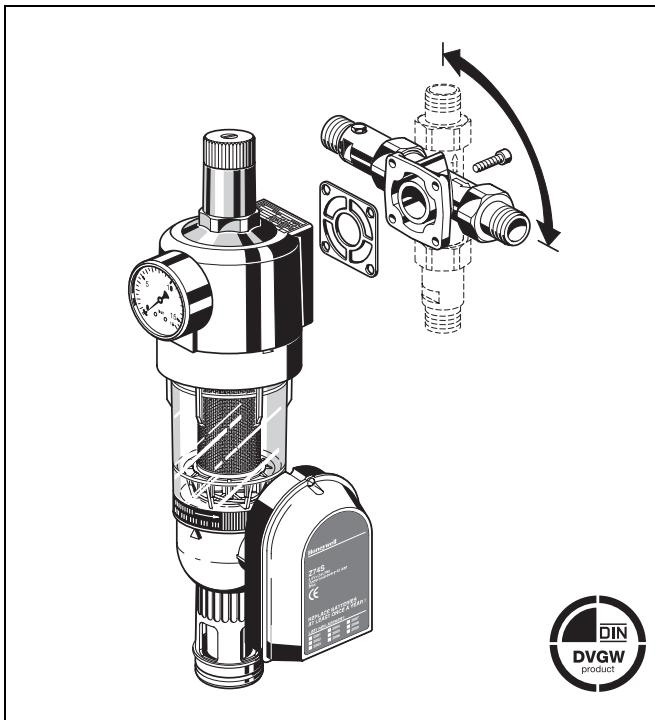

Construction

The combination water supply unit comprises

- Housing with pressure gauge
- Check valve on inlet
- Test point for check valve
- Rotatable connection piece
- Spring bonnet with adjustment knob and setting scale
- Valve insert complete with diaphragm and valve seat
- Flange seal and threaded union connections
- Fine filter in clear filter bowl
- Ball valve with drain connection
- Double ring wrench

Materials

- High quality synthetic material housing
- High grade synthetic material check valve cartridge
- High quality synthetic material spring bonnet valve insert and filter mesh carrier
- Stainless steel fine filter
- Shock-resistant, clear transparent synthetic material filter bowl
- Red bronze connector piece
- Fibre-reinforced NBR diaphragm
- NBR seals

Application

HS74CA combination water supply units integrate pressure reducing valve, reverse rinsing fine filter, non-return valve, and automatic reverse rinsing actuator in one appliance. Therefore, these units comprise all armatures needed for private water supply systems and ensure continuous supply of filtered water.

The fine filter stops the ingress of foreign bodies, for example rust particles, strands of hemp and grains of sand. The check valve protects the mains water system against back pressure, back flow and back syphonage of health threatening liquids. The pressure reducing valve prevents over-pressure damage and reduces water consumption. The automatic reverse rinsing actuator operates with batteries, therefore, there is no need for a bus bar in the area of the water supply. It is responsible for the fully automatic cleaning of the fine filter.

All individual units correspond to the requirements of current DIN/DVGW specifications. Technical features of each unit also apply to the combination assembly.

Special Features

- DIN/DVGW approved
- Inlet pressure balancing - fluctuating inlet pressure does not influence outlet pressure
- Battery-operated automatic reverse rinsing actuator
- Acoustic signal when battery is running low
- Patented reverse rinsing system - fast and thorough cleaning of the filter with small amount of water
- Filtered water supplied even during reverse rinsing
- Reverse rinsing can also be activated manually
- Shock resistant clear synthetic material filter bowl enables easy checking of filter contamination
- Filter and complete filter bowl are replaceable
- The valve insert is of high quality synthetic material and can be fully exchanged
- Meets KTW recommendations for potable Water

Range of Application

Medium	Water
Inlet pressure	Maximum 16.0 bar
Outlet pressure	1.5 - 6.0 bar

The filter is constructed for drinking water installations. In case of a process water application the filter has to be proven individually.

Technical Data

Installation position	Vertical or horizontal, with filter bowl downwards
Operating pressure	Minimum 1.5 bar
Operating temperature	Maximum 30 °C
Batteries*	3 LR6-1.5 V-Mignon/AA size alkali-manganese batteries ¹⁾

Connection size 3/4" - 1 1/4"
 1) Batteries are not supplied with the appliance.

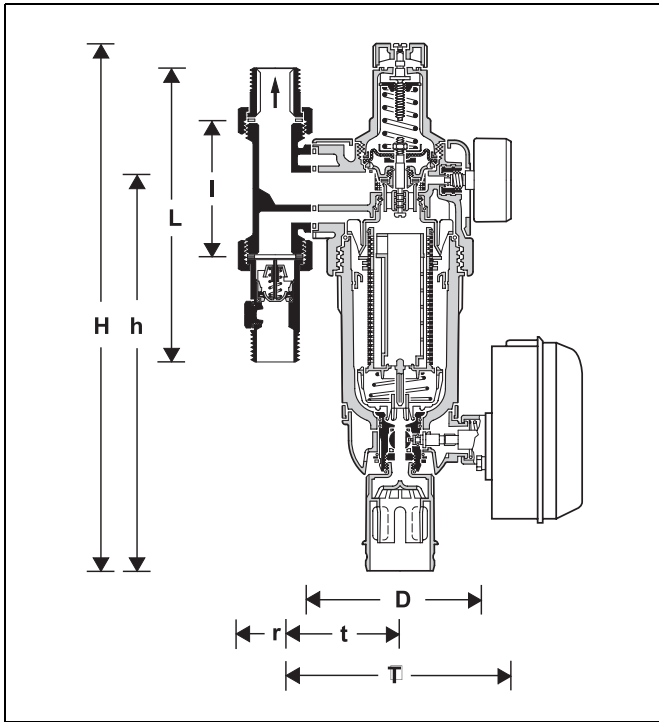

Method of Operation

The fully automatic combination water supply unit combines pressure reducing valve, reverse rinsing fine filter, check valve, and automatic reverse rinsing actuator in one appliance. Water flows first through the check valve. This causes the valve stem to push against the spring force and open the valve. The fine filter insert comprises an upper part and a lower combination section. When in "filtering" position, the small upper filter is closed so that the water can only pass through the main filter from outside to inside. Every 45 days the integrated automatic reverse rinsing actuator opens the ball valve. While the ball valve is opening for "reverse rinsing", the filter is pushed downwards until the water supply to the outer side of the main filter is stopped. Simultaneously, the water flow is opened to the upper part of the filter. The water needed for cleaning the filter passes through the upper sieve, the rotating impeller and the main filter from inside to outside. By this means, the filter is fully cleaned over its whole surface area at the full inlet pressure. The filter automatically switches over to the operating position when the ball valve is closed again. The integral pressure reducing valve functions on a balanced force principle whereby the force exerted by a diaphragm is balanced against the force of an adjustment spring. The inlet pressure has no influence on opening or closing of the valve. Inlet pressure fluctuation does not therefore affect the outlet pressure.

Connection size	R	3/4"	1"	1 1/4"
Weight	approx. kg	3.8	4.4	4.7
Dimensions	mm			
	H	395	395	395
	h	285	285	285
	T	150	150	150
	t	66	66	66
	r	27	27	31
	D	105	105	105
	l	90	100	105
	L	189	212	234
k _{VS} -value		5.5	6.0	6.5
DIN/DVGW Registration Approval No. for FK74C		DW-9311 AT 2316		
Approval No. for RV277		NW-6312 AS 2269		

Options

- HS74CA-...AA = Filter mesh size 95/110 µm
 - HS74CA-...AC = Filter mesh size 50 µm
 - HS74CA-...AD = Filter mesh size 200 µm
- Connection size

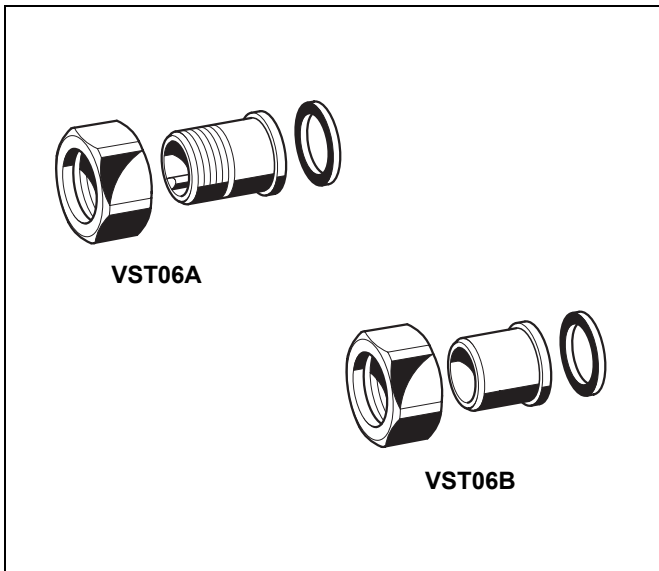

Accessories

VST06-A Connection set

Threaded connections

VST06-B Connection set

Solder connections

Installation Example

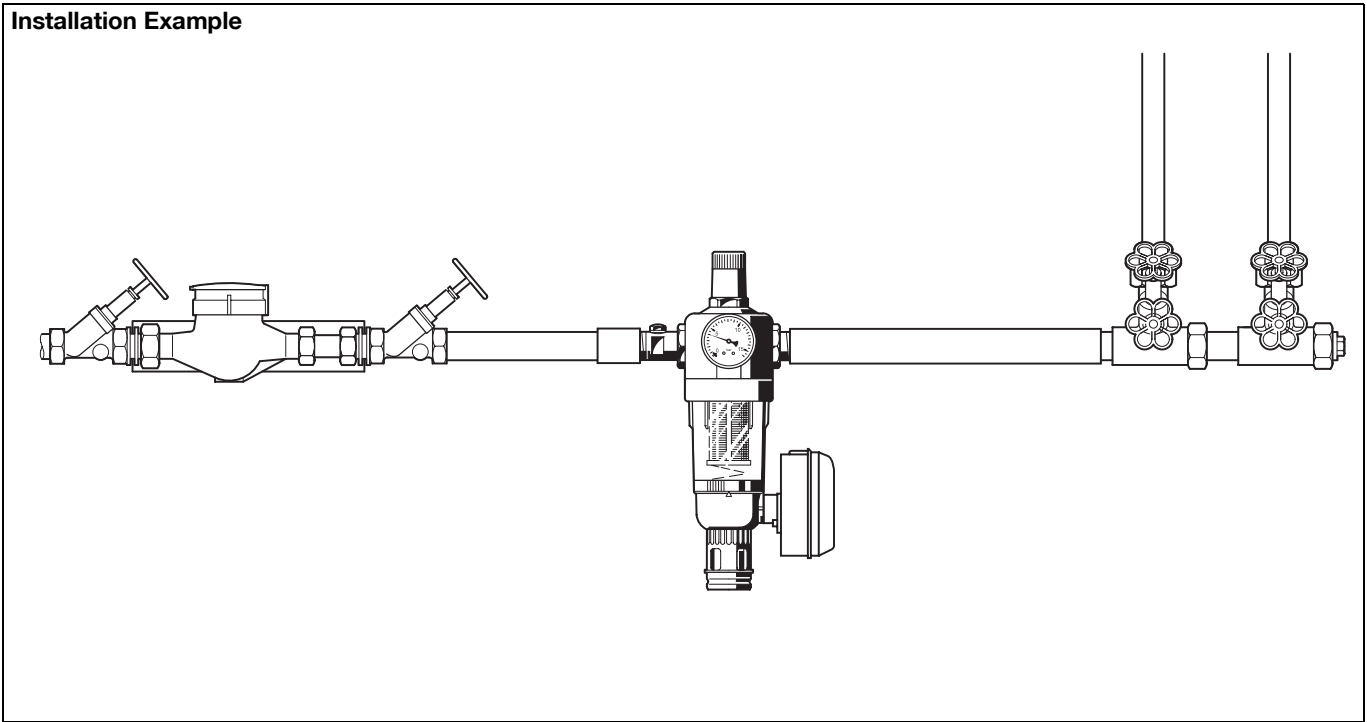

Installation Guidelines

- Install in horizontal or vertical pipework with filter bowl downwards
 - This position ensures optimum filter efficiency
- Install shutoff valves
- Ensure good access
 - Pressure gauge can be read off easily
 - Degree of contamination can be easily seen with clear filter bowl
 - Simplifies maintenance and inspection
- The installation location should be protected against frost
- Fit immediately after water meter
 - Corresponds to DIN 1988, Part 2

Typical Applications

Combination water supply units of this type can be fitted wherever check valves, filters, pressure reducing valves and water distributor units are required. They can also be used for commercial and industrial applications within the limits of their specifications.

Combination water supply units of this type are installed:

- For installation in horizontal or vertical pipework
- As replacement for an existing filter
- Where space is limited
- For protection against noise when the static pressure at take off points exceeds 5.0 bar (DIN 4109)
- If pressure fluctuations in the downstream system must be avoided
- If the downstream system includes appliances which must be protected against dirt
- If the static pressure exceeds the maximum permissible operating pressure of an installation

Flow Diagram

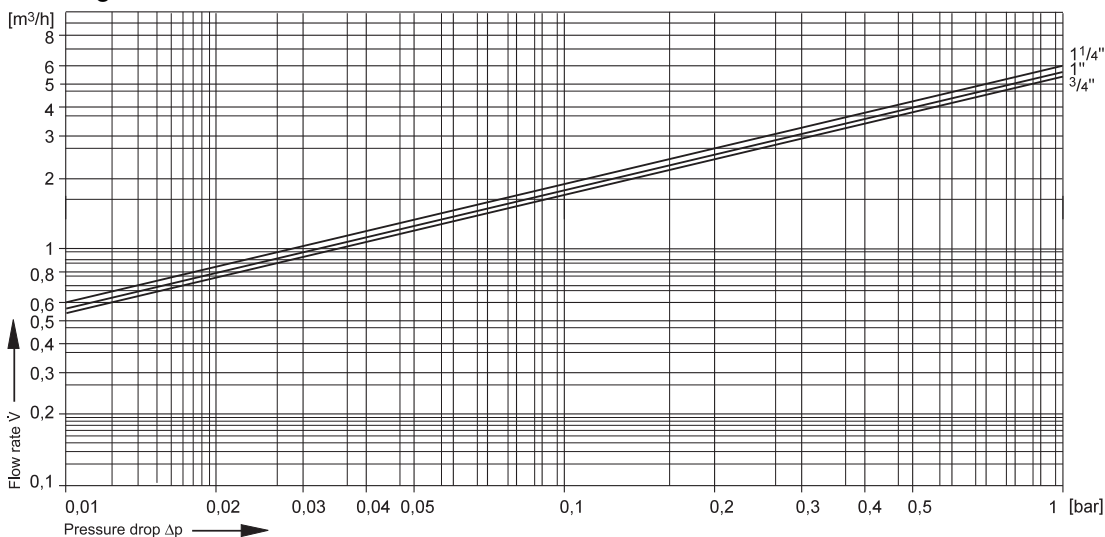

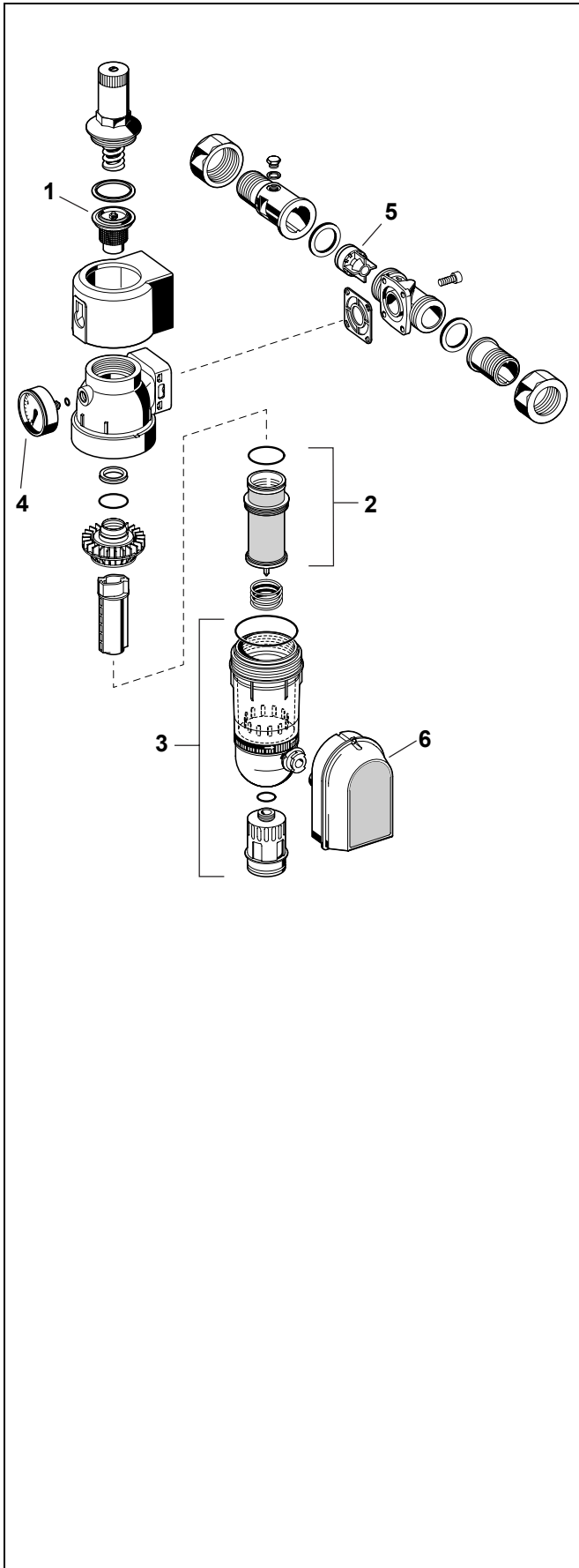

Spare Parts

HS74CA Water Supply Units (from 2002 onwards)

No.	Description	Dimension	Part No.
1	Valve insert complete	3/4" - 1 1/4"	D06FA-1B
2	Filter insert complete		
	Filter mesh 100 μm	3/4" - 1 1/4"	AF74-1A
	Filter mesh 50 μm	3/4" - 1 1/4"	AF74-1C
	Filter mesh 200 μm	3/4" - 1 1/4"	AF74-1D
3	Clear filter bowl complete	3/4" - 1 1/4"	KF74-1A
4	Pressure gauge (0 - 16 bar)		M07M-A16
5	Check valve cartridge	3/4"	2110200
		1"	2164400
		1 1/4"	2164500
6	Automatic reverse rinsing actuator	3/4" - 1 1/4"	Z74S-A
7	Double ring wrench	1/2" - 3/4"	ZR10K-3/4
	For removing the filter bowl (no fig.)	1" - 1 1/4"	ZR10K-1
		1 1/2" - 2"	ZR10K-11/2

Automation and Control Solutions

Honeywell GmbH
 Hardhofweg
 D-74821 Mosbach
 Phone: (49) 6261 810
 Fax: (49) 6261 81309
<http://europe.hbc.honeywell.com>
www.honeywell.com

Manufactured for and on behalf of the
 Environmental and Combustion Controls Division
 of Honeywell Technologies Sàrl, Rolle, Z.A. La
 Pièce 16, Switzerland by its Authorised Repre-
 sentative Honeywell GmbH

EN0H-1131GE23 R1009
 Subject to change without notice
 © 2009 Honeywell GmbH

Honeywell