

HF49

Sludge and Air Separator

Product specification sheet

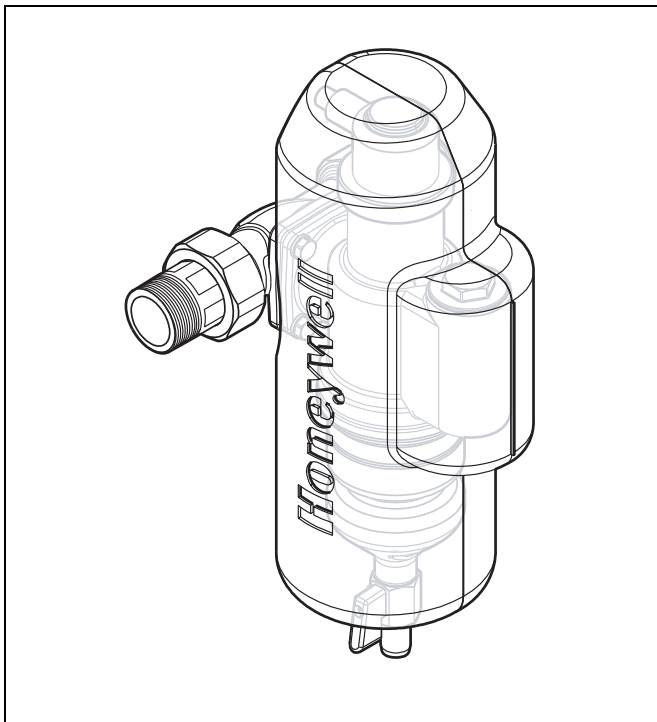

Construction

The sludge and air separator consists of:

- Housing
- Connection piece incl. couplings and seals
- Quick bleeder
- Blind plug including magnetic separator
- Foam insulation jacket
- Ball valve

Materials

- Dezincification resistant brass housing
- Connection piece made of dezincification-resistant brass
- Quick bleeder made of dezincification-resistant brass
- Foam insulation made of PE foam
- EPDM sealing washers

Application

The sludge and air separator serves to separate sludge and air from the heating system. It is equipped with a sludge and contamination reduction feature that functions according to the cyclone principle. This guarantees an effective separation of the particles.

There is an optional phosphate cartridge available to prevent corrosion in aluminium-free heating systems.

Special Features

- swivel connection for vertical or horizontal installation
- quality insulation shell to prevent heat loss
- integrated quick bleeder
- integrated magnet for separation of ferromagnetic metals

Range of Application

The sludge and air separator is installed in the heating circuit (feed and return line) and serves to separate sludge and air from the heater water.

Technical Data

Connection diameter	DN25
Nominal pressure (PN)	10 bar
Operating pressure	max. 10 bar
Nominal flow	3,6 m³/h
Pressure loss during nominal flow rate	0,2 bar
k_{vs} -value	7,8 m³/h
Operating temperature	max. 90°C

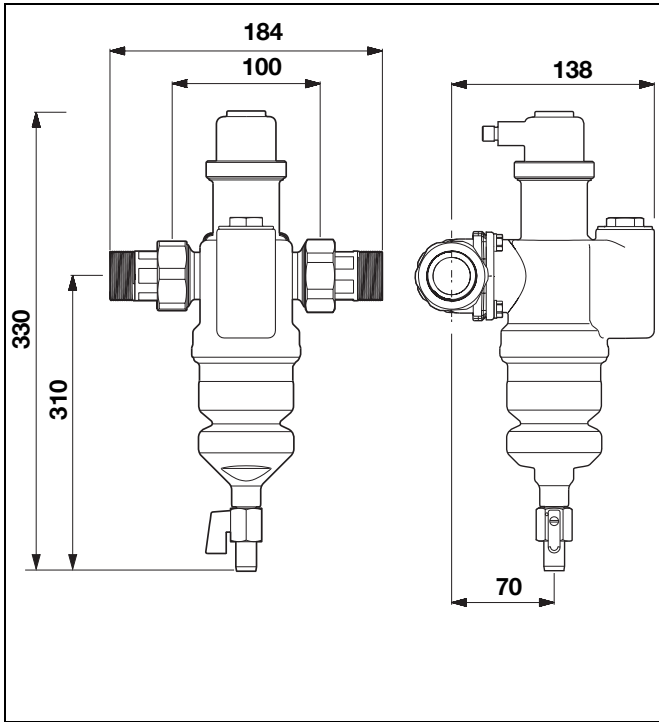

Method of Operation

The heater water separator serves to separate sludge and air from the heater system.

It is equipped with a sludge and contamination reduction that functions according to the cyclone principle. This guarantees an effective separation of the particles.

The heater water separator is equipped with a quick bleeder for the air separation. If there is air in the system, it will rise to the highest point of the heater water separator. The water level drops there, the integrated floater pulls the floater arm down and thereby opens the sealed area. The air bleeds out whereby the water level rises again and the sealed area is closed again.

The optionally available phosphate cartridge counters the corrosion in the heater system. This dosing serves as an additional protection of the heater system; not as a replacement of the basic conditioning of the heater water by inhibitors.

Options

HF49-1A= Standard version

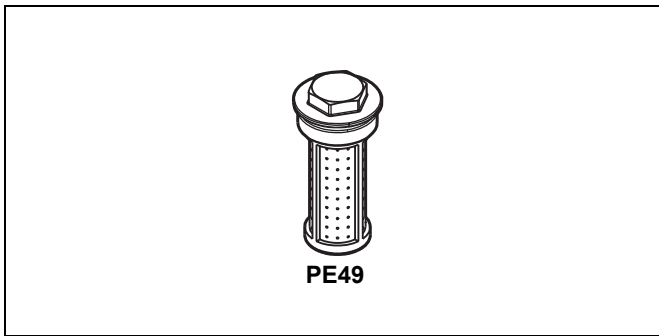

Accessories

PE49 Phosphate cartridge

Phosphate cartridge for protection of the heater system against corrosion.

Use only in heater systems without aluminium materials.

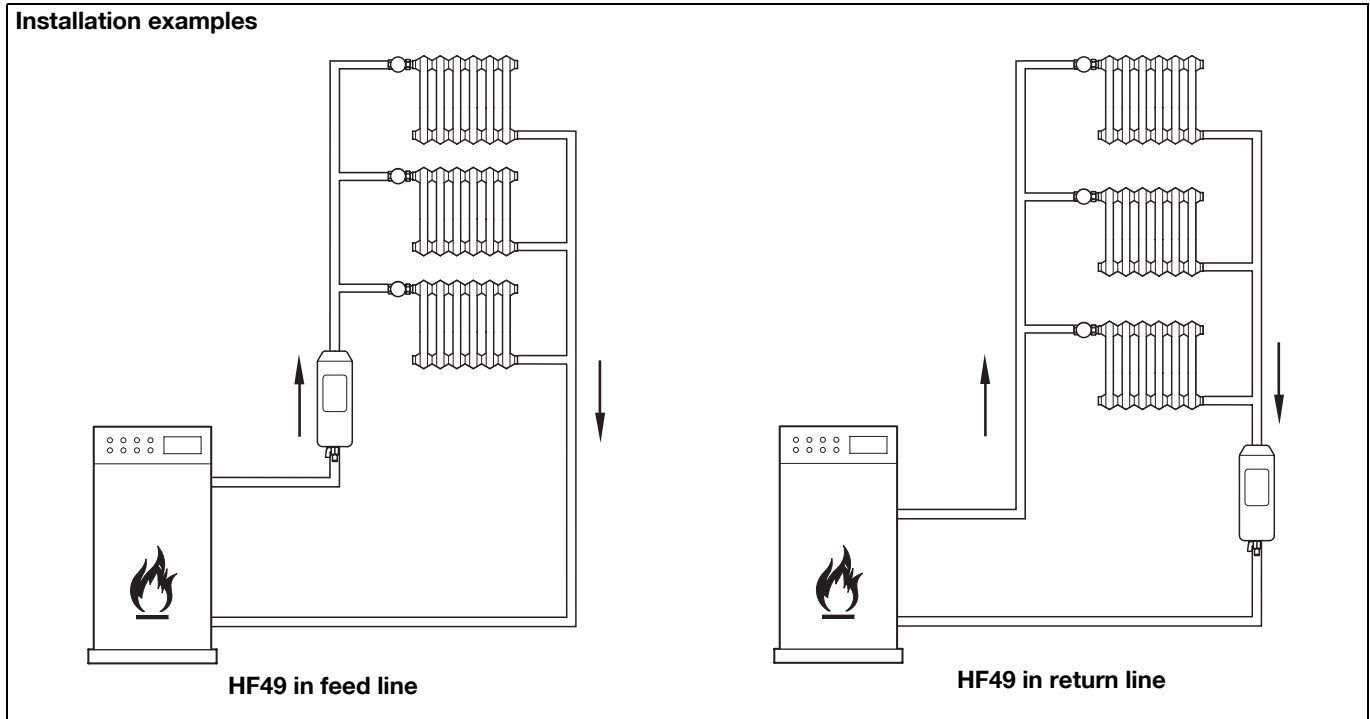

Installation Guidelines

- The sludge and air separator is not suited for:
 - the separation of oils greases, solvents, soaps and other lubricating media
 - the separation of water-solvent materials
- The sludge and air separator is installed in the heating circuit (feed and return line)
- The heating system needs to be rinsed and filled
- The national installation regulations, general guidelines and technical data must be observed during the assembly
- The installation site has to be frost-free and the protection of the device from chemicals, paints, solvents, vapours and environmental influences must be guaranteed
- A coarse dirt separator needs to be installed up front for water with coarse dirt particles
- To ensure the bleeding of the air, the sludge and air separator has to be installed with the quick bleeder upwards
- The separator has to stand vertically; the connection piece can be built into horizontal and vertical lines
- Make sure the seals fit properly. The pressure-sealing tightening of the screws has to be done cross-wise
- Install stop valves ahead and following the sludge and air separator
 - This makes it possible to maintain the sludge and air separator easily without draining the heating system
- Mount the sludge and air separator at easily accessible points in the system

Typical Applications

For installation in the heating circuit to filter out dirt and sludge particles and bleed off air.

This prevents malfunctions and damage to radiators, valves, pumps, and heat generators.

A high efficiency is ensured for the whole heating system.

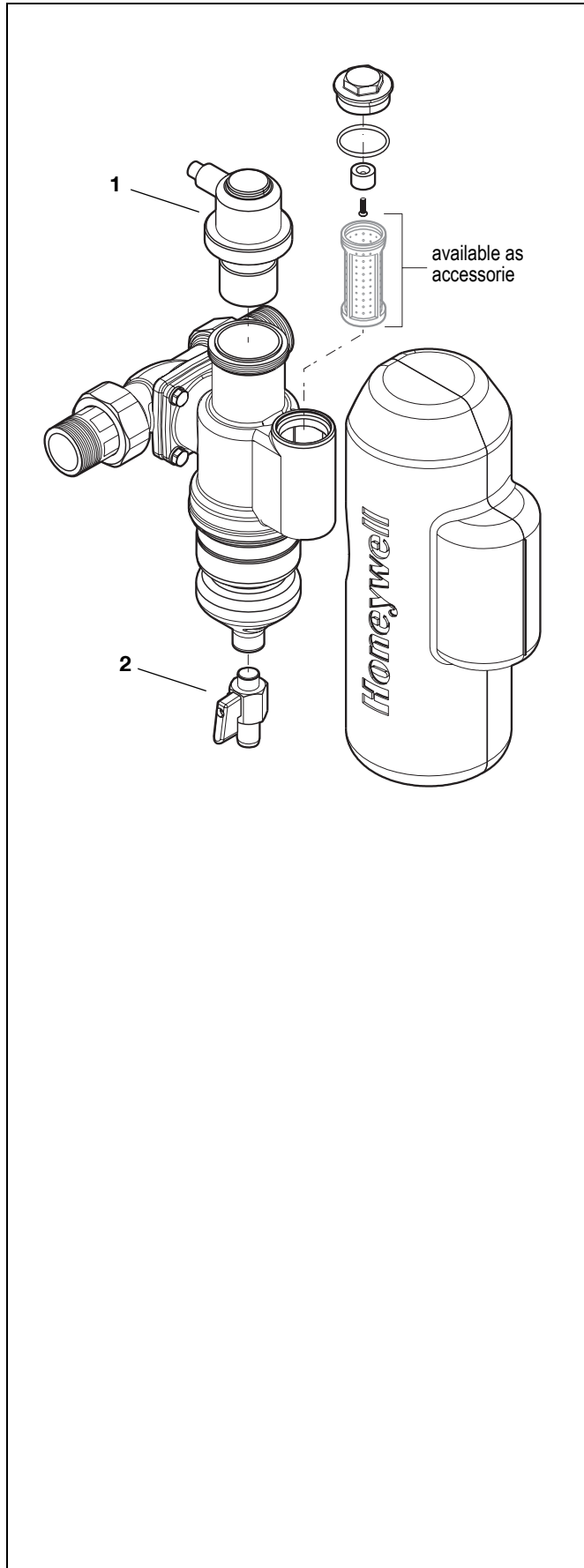

Spare Parts

Sludge and Air Separator HF49 (from 2008 onwards)

- | | | |
|---|----------------|------|
| 1 | Venting insert | EE49 |
| 2 | Ball valve | KH49 |

Automation and Control Solutions

Honeywell GmbH
Hardhofweg
D-74821 Mosbach
Phone: (49) 6261 810
Fax: (49) 6261 81309
<http://europe.hbc.honeywell.com>
www.honeywell.com

Manufactured for and on behalf of the
Environmental and Combustion Controls Division
of Honeywell Technologies Sàrl, Z.A. La Pièce 16,
1180 Rolle, Switzerland by its Authorised Repre-
sentative Honeywell GmbH

EN0H-1549GE23 R0310
Subject to change without notice
© 2010 Honeywell GmbH

Honeywell