

OUTSIDE AIR TEMPERATURE COMPENSATED SUPPLY WATER FLOW TEMPERATURE CONTROL W1

Used in heating systems in which hot water is used as a heating medium, being circulated to the locations where heat is required e.g. radiator heating systems or heating coils in ventilation or air conditioning systems. The controller is also suitable for chilled water supply temperature control.

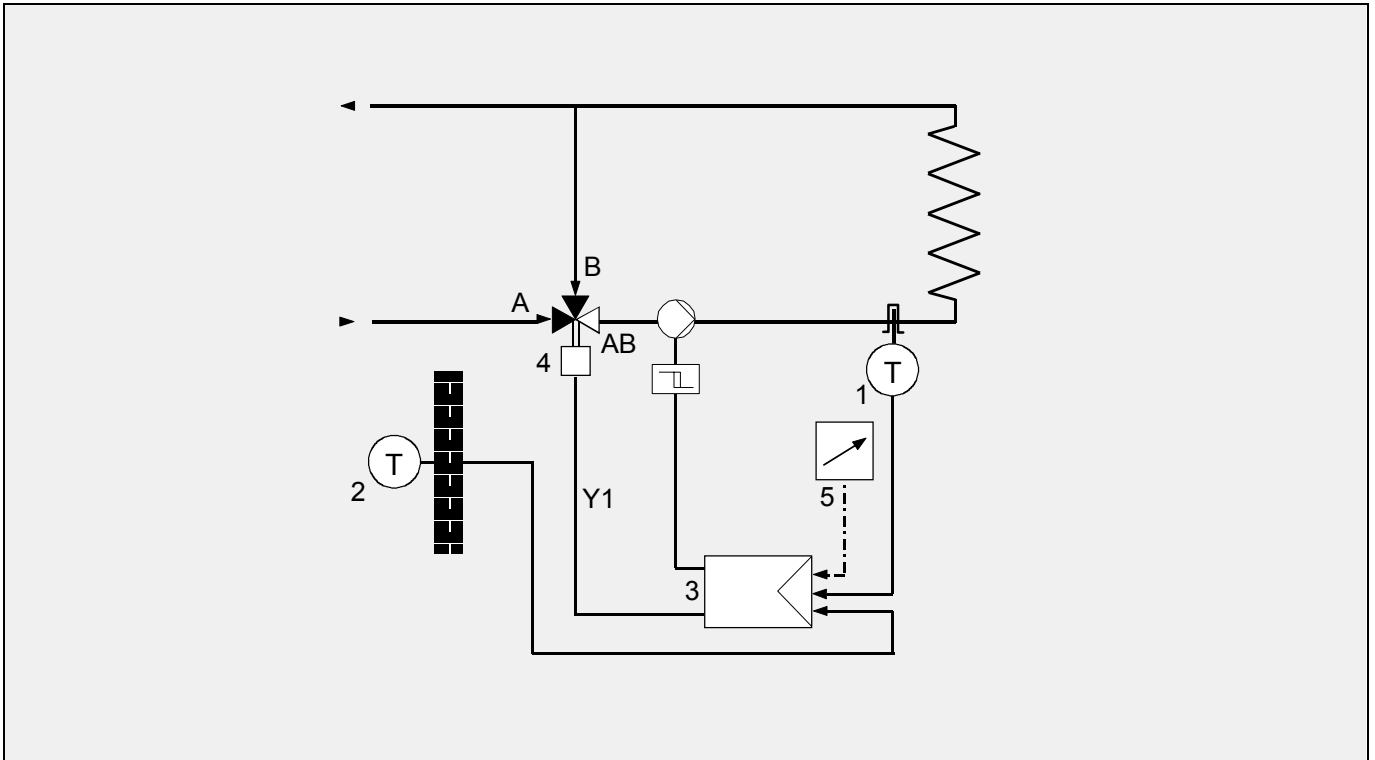

FUNCTIONAL DESCRIPTION

Temperature Control. The supply water flow temperature sensor (1) measures the actual value and the controller (4) compares this value with the actual control point. The control point comprises the basic setpoint value which is continuously compensated by the outside air temperature sensor (2) value. If a deviation between the two values exists, the controller (3) generates a 3-position control signal to reposition the valve (4) to maintain the desired supply water temperature.

In heating applications the controller output is reverse acting and a positive winter compensation authority is used, with decreased outside air temperature the control point is increased.

In cooling applications the controller output is direct acting and a negative summer compensation authority is used, with increased outside air temperature the control point is decreased.

Time Control. Depending on the programmed time schedule of the internal controller real time clock the different operating control modes Comfort, Standby, Night or OFF are selected. In the Standby or Night mode the main temperature setpoint is decreased by the programmed offset values SOFFS (Standby) or NOFFS (Night).

If the configuration parameter C.04 (Ctrltyp) is set to Hi2, automatically the pump switches OFF at outside air temperatures above 8°C, if the valve is closed for more than 5 minutes during Comfort, Standby or Night mode.

In the OFF operating mode the controller automatically closes the valve (4) and switches the pump OFF.

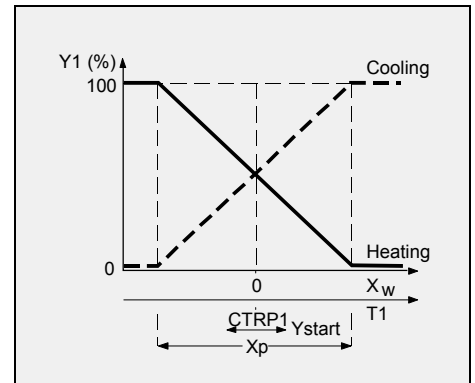

WIRING CONNECTIONS

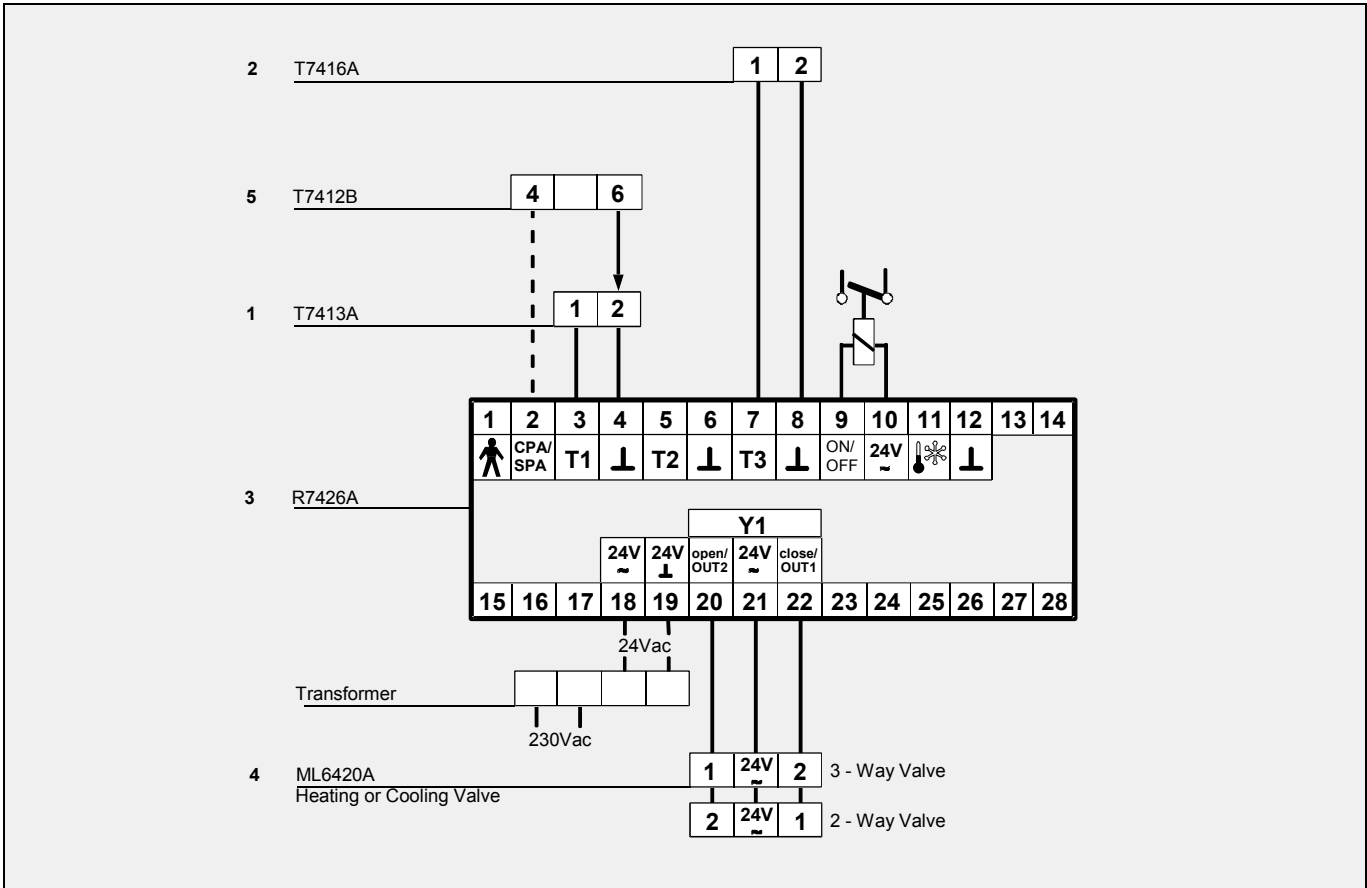

EQUIPMENT LIST

Item	Quantity	Part Number	Description
1	1 plus 1	T7413A1009 or T7413A1066 43193884-001	Immersion Temperature Sensor with Brass Well, 135mm length or Immersion Temperature Sensor for chilled water applications Brass Well, 135mm length
2	1	T7416A1006	Outside Air Temperature Sensor, Wall Mounting
3	1	R7426A1016 or R7426A1008	Temperature Controller with clock or without clock
4	1	ML6420A3007 and V5.....A.....	Valve Actuator and Valve

OPTIONS

Item	Quantity	Part Number	Description
5	1	T7412B1057 or 43193982-001	Remote Setpoint Adjustment Potentiometer, Wall Mounting or Front Panel Mounting

OUTSIDE AIR TEMPERATURE COMPENSATED HOT WATER FLOW TEMPERATURE CONTROL WITH HIGH OR LOW LIMIT RETURN FLOW TEMPERATURE CONTROL

W2

Used in radiator heating systems to control the supply water flow temperature depending on the outside air temperature with minimum limitation of the boiler return flow temperature to prevent corrosion due to condensation of flue gases or maximum limitation of the return temperature in district heating systems.

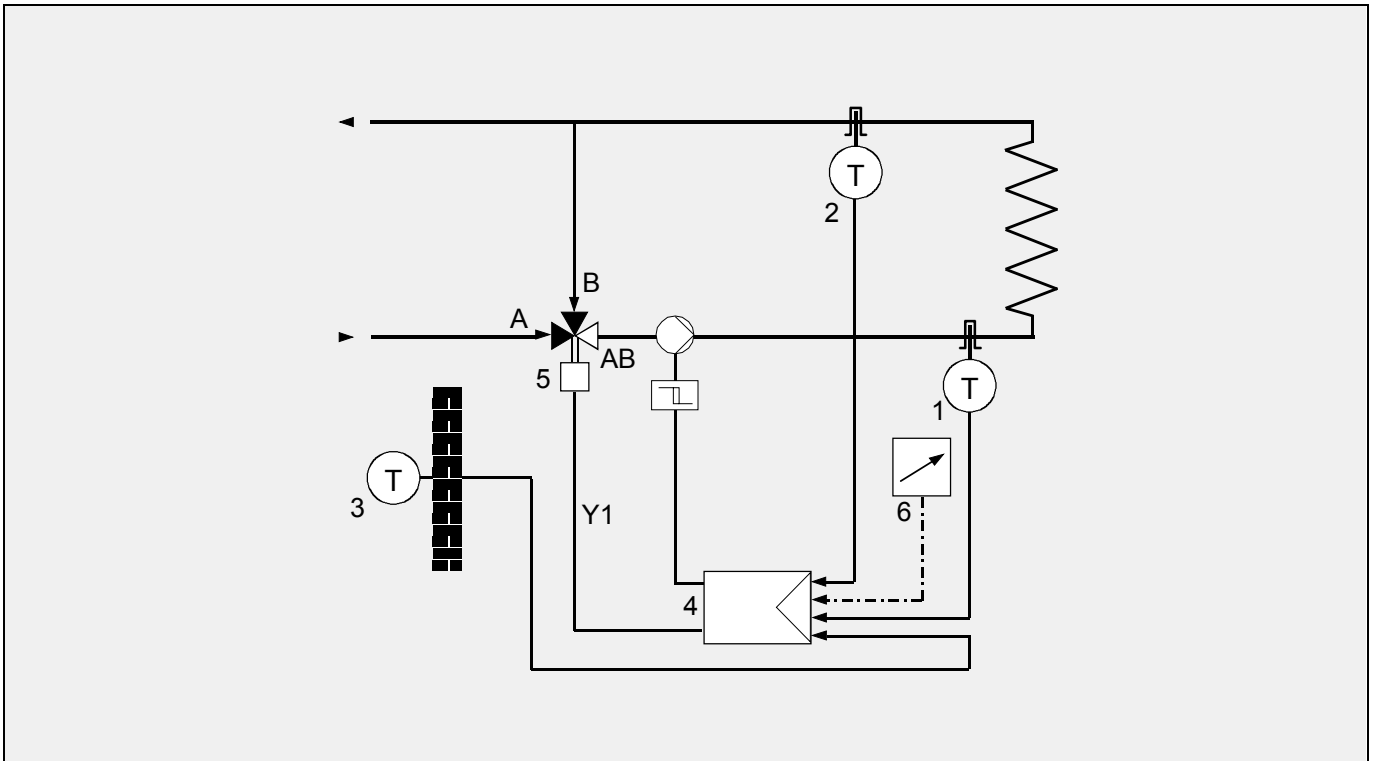

FUNCTIONAL DESCRIPTION

Temperature Control. The supply water flow temperature sensor (1) and return water flow temperature sensor (2) measures the actual values and the controller (4) compares these values with the actual control point and the desired limit setpoint (Wlim). The control point comprises the basic setpoint value which is continuously compensated by the outside air temperature sensor (3) value. If a deviation between these values exists, the controller selects the highest or lowest deviation signal in correspondence with the selected limit function.

Depending on this deviation signal the controller generates a 3-position control signal to reposition the valve (5) to maintain the desired supply or return water flow temperature.

The controller output has to be configured reverse acting for heating applications and the desired positive winter compensation authority determines the reset effect on the main setpoint (W1).

Time Control. Depending on the programmed time schedule of the internal controller real time clock the different operating control modes Comfort, Standby, Night or OFF are selected. In the Standby or Night mode the main temperature setpoint is decreased by the programmed offset values SOFFS (Standby) or NOFFS (Night).

If the configuration parameter C.04 (Ctrltyp) is set to Hi2, automatically the pump switches OFF at outside air temperatures above 8°C, if the valve is closed for more than 5 minutes during Comfort, Standby or Night mode.

In the OFF operating mode the controller automatically closes the valve (5) and switches the pump OFF.

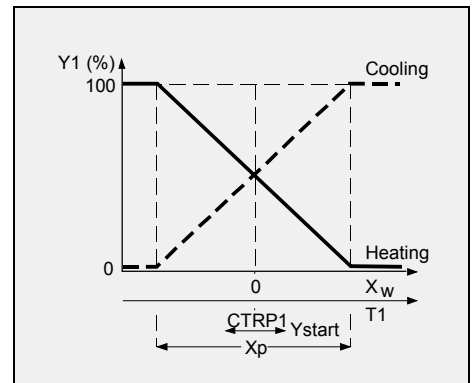

WIRING CONNECTIONS

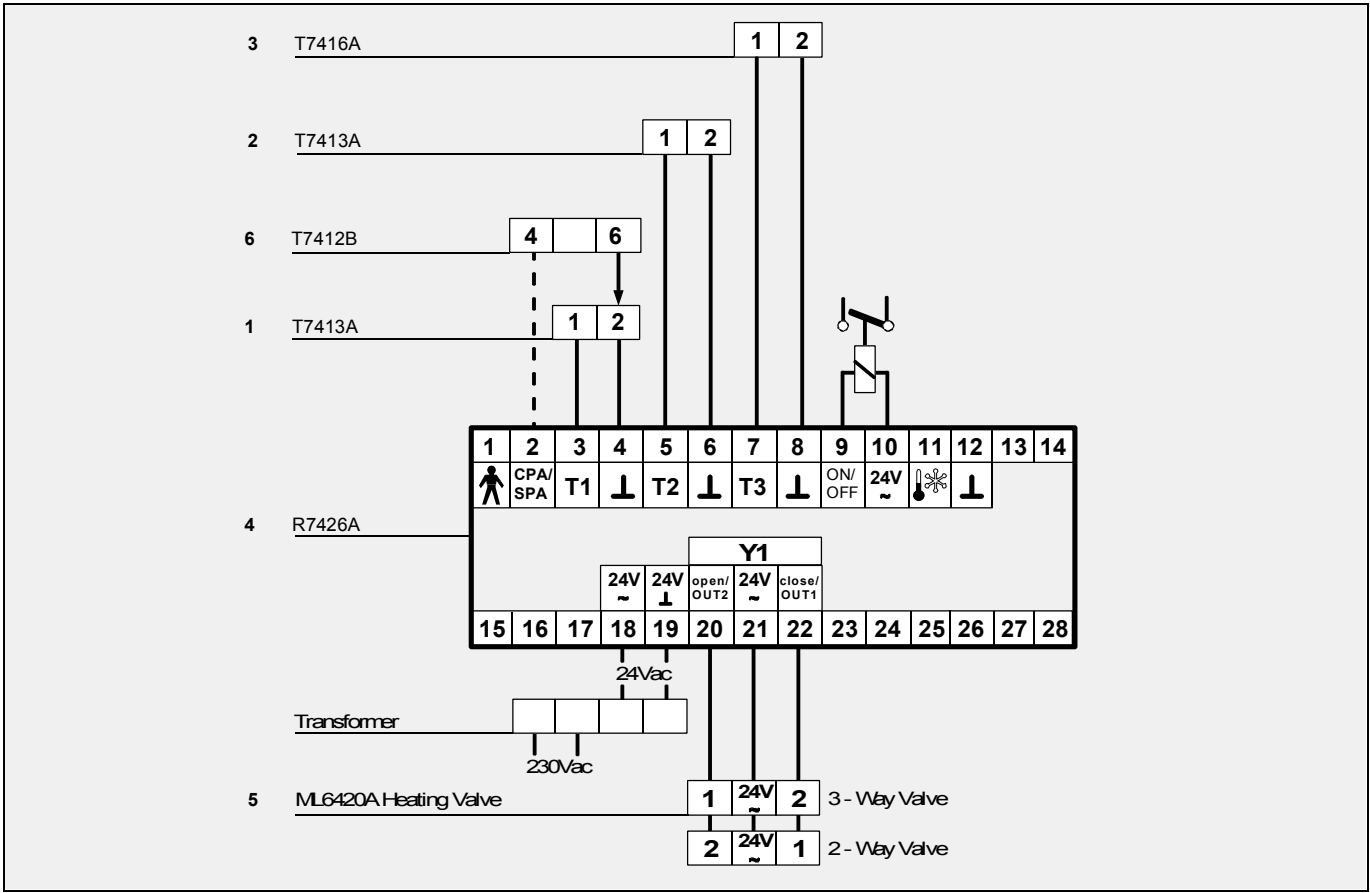

EQUIPMENT LIST

Item	Quantity	Part Number	Description
1+2	2	T7413A1009	Immersion Temperature Sensor with Brass Well, 135mm length
3	1	T7416A1006	Outside Air Temperature Sensor, Wall Mounting
4	1	R7426A1016 or R7426A1008	Temperature Controller with clock or without clock
5	1	ML6420A3007 and V5.....A.....	Valve Actuator and Valve

OPTIONS

Item	Quantity	Part Number	Description
6	1	T7412B1057 or 43193982-001	Remote Setpoint Adjustment Potentiometer, Wall Mounting or Front Panel Mounting

ROOM TEMPERATURE - SUPPLY HOT WATER TEMPERATURE CASCADE CONTROL W3

Used in radiator heating systems to control the supply water flow temperature depending on the room temperature.

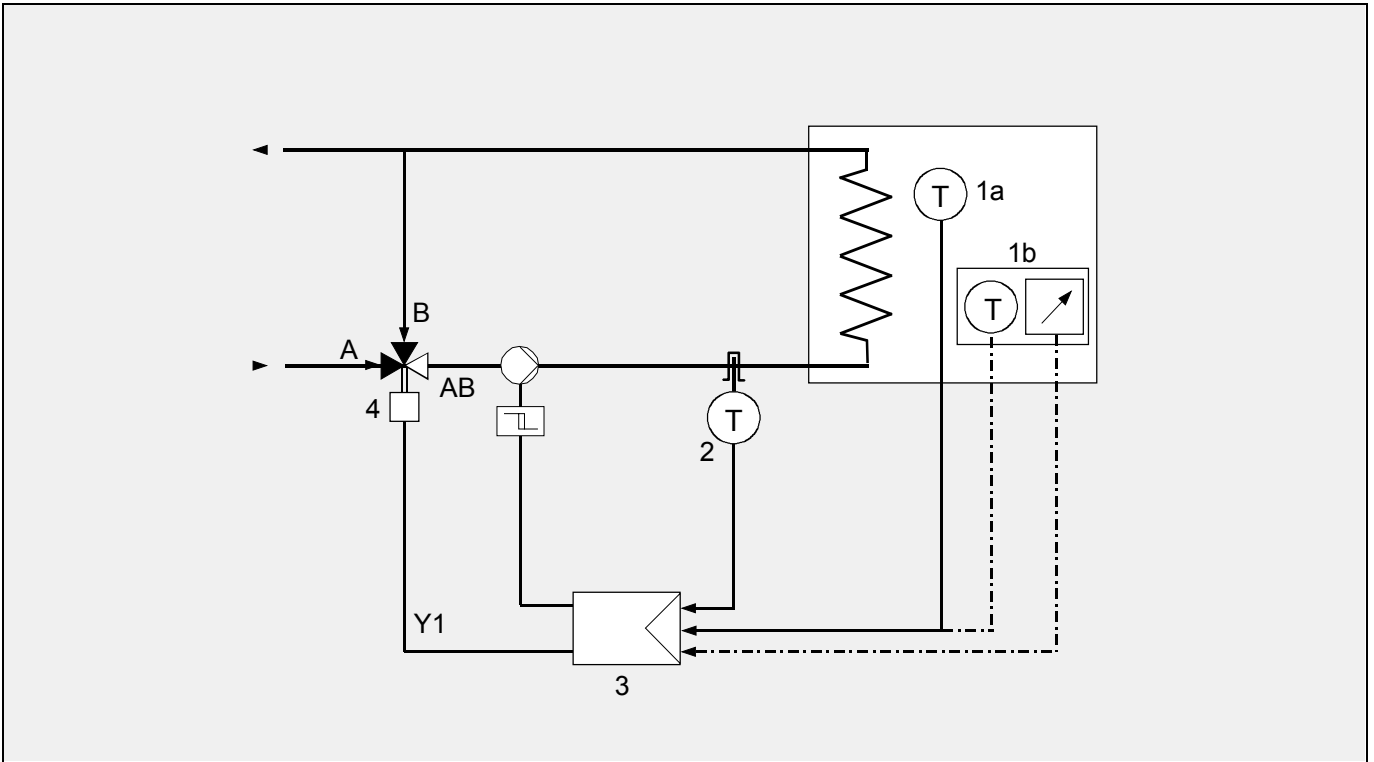

FUNCTIONAL DESCRIPTION

Temperature Control. The room air temperature sensor (1a or 1b) measures the actual value and the controller (4) compares this value with the desired setpoint (W1) of the master loop. Depending on the deviation an internal setpoint for the submaster loop, the supply water flow temperature, is calculated. At zero deviation the supply water flow temperature is controlled at the programmed setpoint (Wcas) and if a deviation exists, the supply water setpoint is altered. The reset span of the supply water setpoint is limited by the reset span adjustment (Rcas) and the limit setting (Wlim).

The supply water flow temperature sensor (2) measures the actual value and the controller (4) compares this value with the desired internal calculated setpoint.

If a deviation between the two values exists, the controller generates a 3-position control signal to reposition the valve (5) to maintain the desired supply water flow temperature.

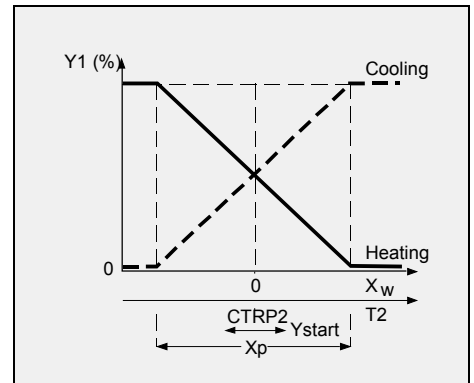

Time Control. Depending on the programmed time schedule of the internal controller real time clock the different operating control modes Comfort, Standby, Night or OFF are selected. In the Standby or Night mode the main temperature setpoint is decreased by the programmed offset values SOFFS (Standby) or NOFFS (Night).

If the configuration parameter C.04 (Ctrltyp) is set to Hi2, automatically the pump switches OFF, if the valve is closed for more than 5 minutes during Comfort, Standby or Night mode.

In the OFF operating mode the controller automatically closes the valve (5) and switches the pump OFF. The night cycle program compares the actual room temperature to the low cycle limits and either turns the heat and pump on or off or does nothing. If the temperature is below the limit setpoint (NightLow) the controller opens fully the heating valve and switches the pump ON. When the temperature reaches the other limit (1K differential), the valve closes and the pump switches OFF.

WIRING CONNECTIONS

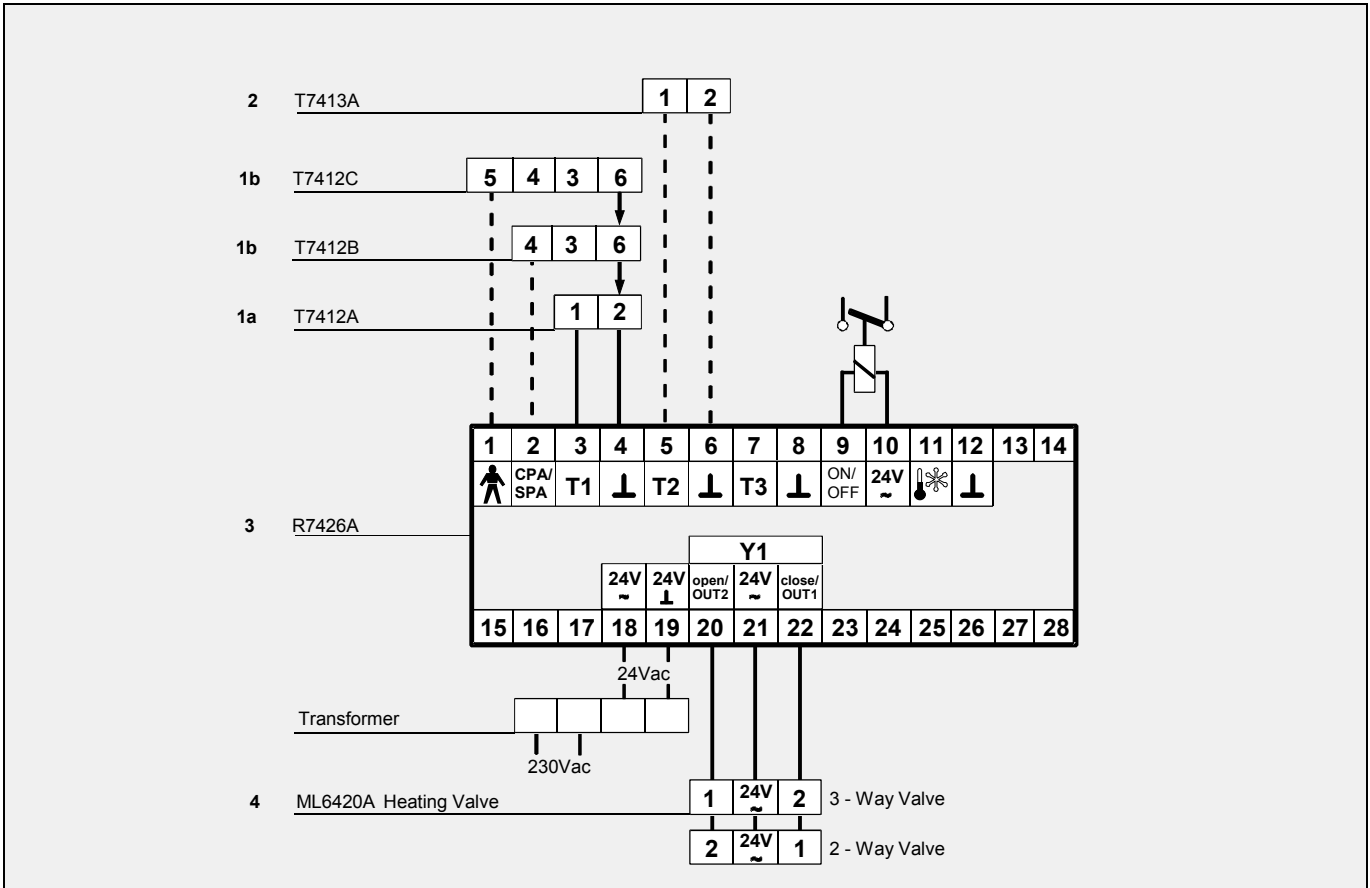

EQUIPMENT LIST

Item	Quantity	Part Number	Description
1a+1b	1	T7412A1018 or T7412B1057	Room Temperature Sensor or Room Temperature Sensor with CPA
2	1	T7413A1009	Immersion Temperature Sensor with Brass Well, 135mm length
3	1	R7426A1016 or R7426A1008	Temperature Controller with clock or without clock
4	1	ML6420A3007 and V5....A....	Valve Actuator and Valve

HONEYWELL

Control Products

Honeywell AG
Böblinger Straße 17
D-71101 Schönaich
Phone: (49) 7031 63701
Fax: (49) 7031 637493
<http://europe.hbc.honeywell.com>

Subject to change without notice. Printed in Germany

EN3C-0161GE02 R0602

Manufacturing location certified to

DIN EN
ISO 9001