

## Excel 10

### W7750A,B CONSTANT VOLUME AHU CONTROLLER



#### SYSTEM ENGINEERING

#### Contents

<b>Introduction</b>	3
Description of Devices	3
Control Application	4
Control Provided	4
Products Covered	5
Organization of Manual	5
Applicable Literature	5
Product Names	5
Agency Listings	6
Abbreviations and Definitions	6
Construction	8
Controllers	8
Performance Specifications	10
Inputs/Outputs	14
Analog Inputs	14
Digital Inputs	15
Triac Outputs (W7750B only)	15
Wall Modules	15
Configurations	18
General	18
Allowable Heating and Cooling Equipment Configurations	19
Staged Heating/Cooling Control	20
Modulating Heating/Cooling Control	20
Heat Pump Control	20
Economizer Control	21
Pneumatic Actuator Control	21
Mixed-Output-Type Control	22
Occupancy Sensor	22
Window Open/Closed Digital Input	23
Wall Module Options	23
Dirty Filter Monitor	23
Indoor Air Quality (IAQ) Override	23
Smoke Control	23
Modes of Operation	23
<b>Application Steps</b>	25
Overview	25
Step 1. Plan the System	25
Step 2. Determine Other Bus Devices Required	26
Step 3. Lay Out Communications and Power Wiring	26
E-Bus Layout	26
Power Wiring	28
Power Budget Calculation Example	29
Line Loss	29



Step 4. Prepare Wiring Diagrams .....	32
General Considerations.....	32
W7750 Controllers.....	32
Digital Outputs:.....	34
E-Bus Termination Module.....	39
Step 5. Order Equipment.....	40
Step 6. Configure Controllers.....	43
Step 7. Troubleshooting .....	43
Troubleshooting Excel 10 Controllers and Wall Modules.....	43
Temperature Sensor and Setpoint Potentiometer Resistance Ranges.....	44
Alarms .....	44
Broadcasting the Service Message.....	45
W7750 Controller Status LED .....	46
T7770C,D Wall Module Bypass Pushbutton and Override LED.....	46
T7780A DDWM Bypass Pushbutton and LCD Display Occupancy Symbols.....	46
<b>Appendices .....</b>	<b>47</b>
Appendix A. Using E-Vision to Commission a W7750 Controller. ....	47
Sensor Calibration.....	47
Setting the Pid Parameters.....	47
Appendix B. Sequences of Operation. ....	48
Common Operations .....	49
Room Temperature Sensor (RmTemp) .....	50
Remote Setpoint (RmtStptPot) .....	50
Setpoint Limits (LoSetptLim and HiSetptLim).....	50
Bypass Mode (StatusOvr and StatusLed).....	50
BypassTime .....	50
OverrideType .....	50
OverridePriority.....	50
Cycles per Hour (ubHeatCph and ubCoolCph).....	51
T7770C,D or T7780A DDWM Bypass Pushbutton Operation .....	51
Standby Mode (StatusOcySen) .....	51
Continuous Unoccupied Mode.....	52
Occupancy Mode and Manual Override Arbitration .....	52
Time Clock (Occ_Time_Clock) .....	52
Schedule Master (Sched_Master) .....	52
Setpoint Ramping .....	53
Recovery Ramping for Heat Pump Systems .....	53
Fan Operation.....	54
Window Sensor (StatusWndw).....	54
Smoke Control.....	54
Demand Limit Control (DLC) .....	54
Dirty Filter Monitor .....	54
Start-Up .....	54
Temperature Control Operations.....	55
Staged Cooling Control.....	55
Staged Heating Control .....	56
Cascade Control of Modulating Cooling/Heating.....	57
Series 60 Modulating Control .....	57
Pulse Width Modulating (PWM) Control.....	57
Outdoor Air Lockout of Heating/Cooling .....	57
Economizer Damper Control .....	57
Indoor Air Quality (IAQ) Override.....	58
Discharge Air Low Limit Control .....	58
Economizer Enable/Disable Control .....	58
Appendix C. Complete List of Excel 10 W7750 Controller User Addresses. ....	58
Appendix D. Q7750A Excel 10 Zone Manager Point Estimating Guide. ....	154
Approximate Memory Size Estimating Procedure. ....	154
Appendix E. Sensor Data for Calibration.....	155
Resistance Sensors. ....	155
Voltage/Current Sensors. ....	157

# INTRODUCTION

## Description of Devices

The W7750 is the Constant Volume Air Handling Unit (CVAHU) Controller in the Excel 10 product line family. The CVAHU is a LonMark® compliant device designed to control single zone and heat pump air handlers. W7750 systems control the space temperature in a given zone by regulating the heating and cooling equipment in the air handler that delivers air to that space. The W7750 air handler is typically an all-in-one constant air volume packaged unit, located on the roof of the building. In addition to standard heating and cooling control, the W7750 provides many options and advanced system features that allow state-of-the-art commercial building control. The W7750 Controller is capable of stand-alone operation; however, optimum functional benefits are achieved when the network communication capabilities are used. The W7750 utilizes the Echelon® LonWorks® network (E-Bus) for communications, and conforms with the Echelon® LonMark® HVAC

Interoperability standard for Roof Top Unit Controllers (see Fig. 8).

The T7770 direct-wired Wall Modules or the network configurable T7780A Digital Display Wall Module (DDWM) are used in conjunction with W7750 Controllers. The zone controlled by the W7750 Controller typically can use a T7770A through D Wall Module or a T7780A DDWM which includes a temperature sensor for space temperature measurement. Additional features available in T7770A through D models include analog setpoint input knob, override digital input pushbutton, override status LED and E-Bus network access jack. The DDWM includes an LCD panel for controller status display and keypad for user interface and an E-Bus network access jack.

The Q7750A Excel 10 Zone Manager is a communications interface that allows devices on the E-Bus network to communicate with devices on the standard EXCEL 500® System C-Bus. Fig. 1 shows an overview of a typical system layout. The Q7750A also provides some control and monitoring functions.

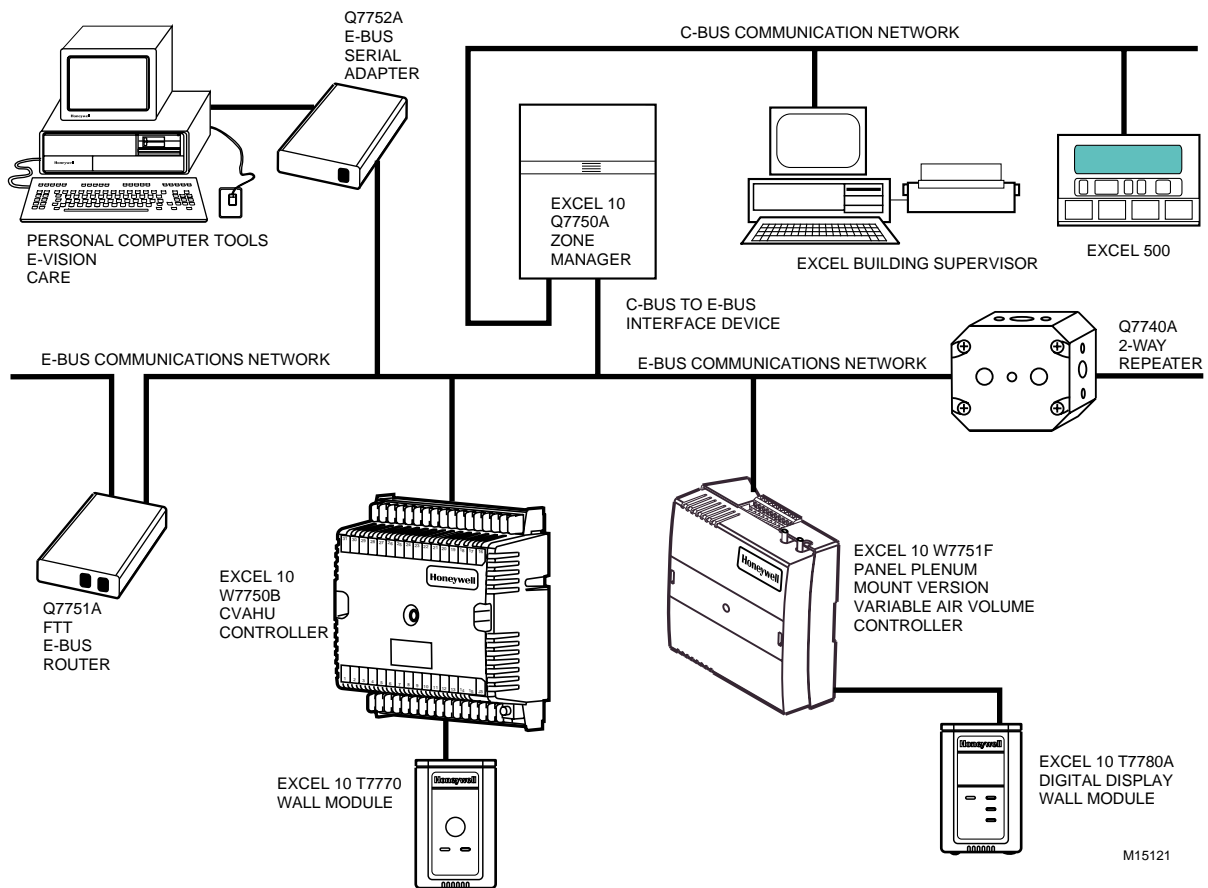

Fig. 1. Typical system overview.

## Control Application

W7750 systems in commercial buildings typically incorporate a packaged air handler system that delivers a constant volume of air at preconditioned temperatures to the zone being served. Each zone is usually serviced by a separate AHU; however, sometimes two or more AHUs service the same zone. Note that the W7750 is not designed to control Variable Air Volume (VAV) air handlers or Multi-Zone air

handlers, where one air handler simultaneously controls the space temperature in many zones.

The W7750 can control staged or modulating heating and cooling coils, mixed air economizer dampers, and the system fan. Control of heat pump units, where the compressor(s) is used for both cooling and heating, is also provided. The zone the W7750 services can use a T7770 or a DDWM for space temperature sensing and an E-Bus network access for users. Fig. 2 shows a typical W7750 control application.

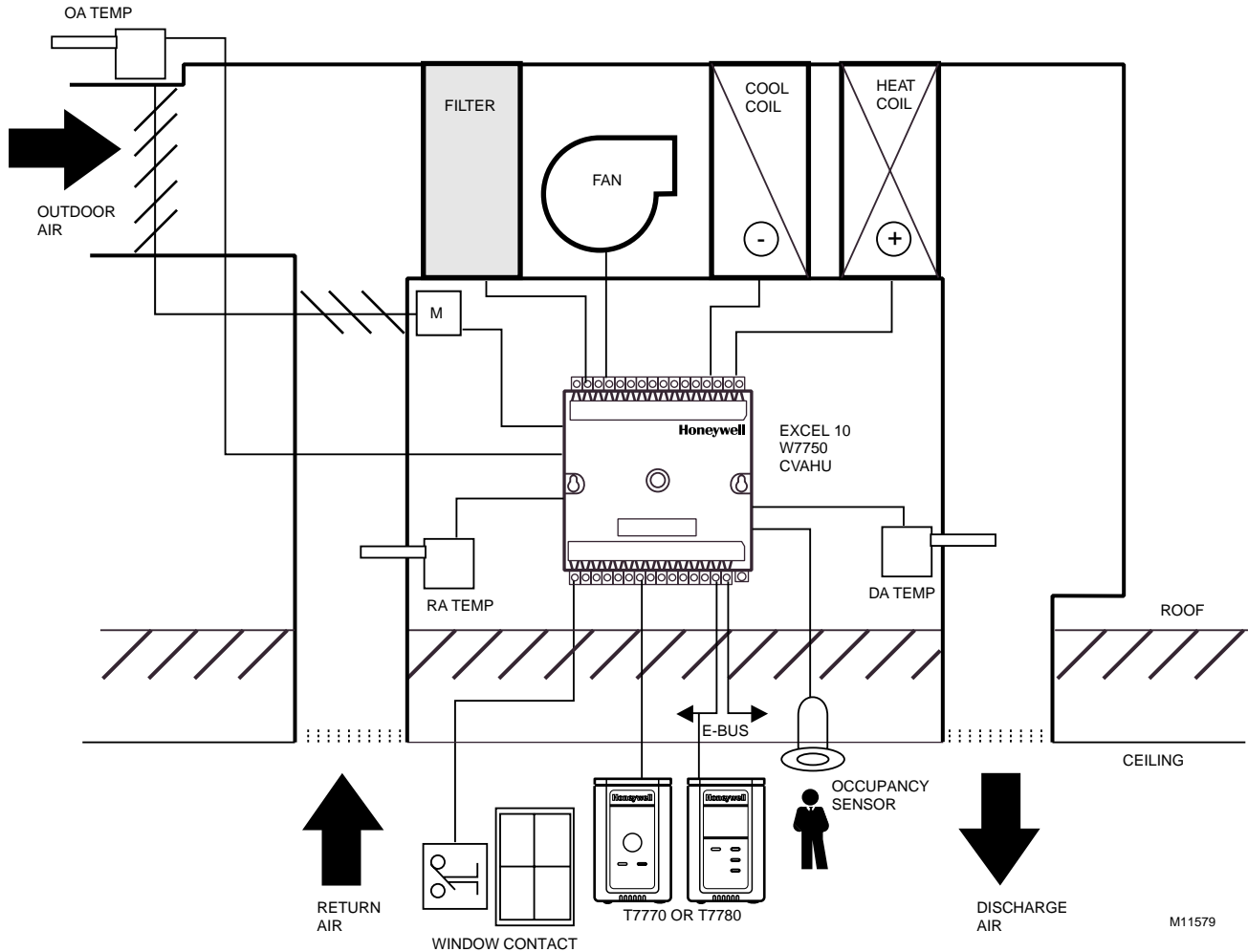

Fig. 2. Typical W7750 control application.

## Control Provided

The W7750 Controller is designed to control a single air handler to maintain the units space temperature at the current setpoint. Heating and cooling control is provided for either staged or modulating equipment. Up to four stages of mechanical cooling and up to four stages of heating are allowed. Modulating outputs can be either *floating type* such as a Series 60 control, or Pulse Width Modulated (PWM) control.

The economizer dampers can be controlled directly with floating or PWM outputs, or indirectly using a digital output as an enable/disable signal to a packaged economizer

controller. The economizer enable function, which decides when to allow outdoor air to be used for free cooling, can be configured to one of ten strategies based on the inputs. For more details, see Appendix B—Sequences of Operation. When the economizer position is controlled from the W7750, the minimum position setting (for ventilation requirements) can be adjusted based on indoor air quality (IAQ) needs in the space. IAQ monitoring is provided through either a CO<sub>2</sub> sensor or a digital input from a space-mounted IAQ limit switch.

For heat pump configurations, up to four compressors can be controlled, along with up to four stages of auxiliary heat, and a heat/cool change over valve. Including the supply fan, the

combination of these items may not exceed eight outputs if a W7750B is used, or six outputs for a W7750A.

Like the W7751 VAV Box Controller, the W7750 Controller can monitor a space-mounted occupancy sensor, and a door/window contact. These inputs affect the operational mode of the controller (see Table 5 for a list of all possible modes of operation).

The W7750 Controller allows other controllers in the system to use the physical inputs and outputs. A digital input and an analog input can be configured to read switch states and voltage sensor values, respectively, and send them out over the E-Bus network. Another device, such as the Q7750A Zone Manager, can use these values in custom control strategies. Additionally, two of the W7750 digital outputs are available for control program use. These outputs only respond to signals sent over the network, and are not controlled by the W7750 internal control algorithms.

## Products Covered

This System Engineering Guide describes how to apply the Excel 10 family of W7750 CVAHU Controllers and related accessories to typical applications. The specific devices covered include:

- W7750A,B Controllers.
- T7770A through D Wall Modules.
- T7780A DDWM.
- Q7750A Excel 10 Zone Manager.
- Q7751A,B Router (FTT to FTT and TPT to FTT).
- Q7752A Serial Interface.
- Q7740A,B Repeaters (2-way and 4-way).
- 209541B FTT Termination Module.

## Organization of Manual

This manual is divided into three basic parts: the Introduction, the Application Steps, and the Appendices that provide supporting information. The Introduction and Application Steps 1 through 5 provide the information needed to make accurate material ordering decisions. Application Step 6 and the Appendices include configuration engineering that can be started using Excel E-Vision PC Software after the devices and accessories are ordered. Application Step 7 is troubleshooting.

The organization of the manual assumes a project is being engineered from start to finish. If an operator is adding to, or is changing an existing system, the Table of Contents can provide the relevant information.

## Applicable Literature

The following list of documents contains information related to the Excel 10 W7750 CVAHU Controller and the EXCEL 5000® OPEN™ SYSTEM in general.

Form No.	Title
74-2076C	Excel 10 Technical Literature Collation
74-2956	Excel 10 W7750A,B Controller Specification Data
74-2697	Excel 10 T7770A,B,C,D,E,F,G Wall Module Specification Data
74-2955	T7780A Digital Display Wall Module Specification Data
74-2950	Excel 10 Q7750A, Zone Manager Specification Data
74-2952	Excel 10 Q7751A,B Router Specification Data
74-2954	Excel 10 Q7752A Serial Interface Specification Data
74-2858	Excel 10 Q7740A,B FTT Repeaters Specification Data
74-2951	Excel 10 Q7750A Zone Manager Checkout and Test Manual
95-7521	Excel 10 W7750A,B Controller Installation Instructions
95-7538	Excel 10 T7770A,B,C,D,E,F,G Wall Module Installation Instructions
95-7509	Excel 10 Q7750A Zone Manager Installation Instructions
95-7510	Excel 10 Q7751A,B Router Installation Instructions
95-7511	Excel 10 Q7752A Serial Interface Installation Instructions
95-7516	Excel 10 SLTA Connector Cable Installation Instructions
95-7555	Excel 10 Q7740A,B FTT Repeaters Installation Instructions
95-7554	Excel 10 209541B Termination Module Installation Instructions
74-2588	Excel E-Vision User's Guide
74-5587	CARE User's Manual
74-1392	CARE Excel 10 Zone Manager User's Guide
74-5577	CARE Icon Guide
74-2039	XBS User's Manual
74-5018	XBS Application Guide

## Product Names

The W7750 Controller is available in two models:

- **W7750A** Constant Volume AHU Controller - W7750A Version.
- **W7750B** Constant Volume AHU Controller - W7750B Version.

The T7770 Wall Module is available in four models. The T7770 Wall Modules will work with all Excel 5000 and Excel 10 Controllers (except the W7751A,C,E,G):

- **T7770A1xxx** Wall Module with nonlinearized 20 Kohm NTC sensor only.
- **T7770A2xxx** Wall Module with nonlinearized 20 Kohm NTC sensor and E-Bus network jack.
- **T7770B1xxx** Wall Module with nonlinearized 20 Kohm NTC sensor, 10 Kohm setpoint, and E-Bus network jack.
- **T7770C1xxx** Wall Module with nonlinearized 20 Kohm NTC sensor, 10 Kohm setpoint, bypass button and LED, and E-Bus network jack.
- **T7770D1xxx** Wall Module with nonlinearized 20 Kohm NTC sensor, bypass button and LED, and E-Bus network jack.

NOTE: The T7770B,C Models are available with a absolute 55 to 85°F (10 to 85°C) or a relative scale plate adjustable in E-Vision to ± 18°F (± 5°C).

The T7780A DDWM is available in one model:

- **T7780A** DDWM displays and provides space temperature, setpoint, Occ/Unocc override, Application

Mode, Fan mode/speed selection, and E-Bus network.

Other products:

- **Q7750A** Excel 10 Zone Manager.
- **Q7751A,B** Bus Router.
- **Q7752A** Serial Adapter.
- **Q7740A,B** FTT Repeaters.
- **209541B** FTT Termination Module.

Refer to Table 11 in Application Step 5. Order Equipment for a complete listing of all available part numbers.

NOTE: The Q7750A Zone Manager is referred to as (E-Link) in internal software and CARE.

## Agency Listings

Table 1 provides information on agency listings for Excel 10 products.

**Table 1. Agency Listings.**

Device	Agency	Comments
<b>W7750A,B Controllers</b>	UL	Tested and listed under UL916 (file number E87741).
	cUL	Listed (E87741).
	CE	General Immunity per European Consortium Standards EN50081-1 (CISPR 22, Class B) and EN 50082-1:1992 (based on Residential, Commercial, and Light Industrial). EN 61000-4-2: IEC 1000-4-2 (IEC 801-2) Electromagnetic Discharge. EN 50140, EN 50204: IEC 1000-4-3 (IEC 801-3) Radiated Electromagnetic Field. EN 61000-4-4: IEC 1000-4-4 (IEC 801-4) Electrical Fast Transient (Burst). Radiated Emissions and Conducted Emissions: EN 55022: 1987 Class B. CISPR-22: 1985.
	FCC	Complies with requirements in FCC Part 15 rules for a Class B Computing Device. Operation in a residential area can cause interference to radio or TV reception and require the operator to take steps necessary to correct the interference.
<b>T7770A through D Wall Modules</b>	UL	(Not applicable.)
	cUL	(Not applicable.)
	FCC	(Not applicable.)
<b>T7780A DDWM</b>	CE	Emissions; EN50081-1 and EN55022 (CISPR 22 Class B), Immunity 50082-1
	UL & cUL	Tested and listed under UL916. S8L9 Energy Management Equipment.
	FCC	Complies with requirements in FCC Part 15 rules for a Class A Computing Device.
<b>Q7750A Excel 10 Zone Manager</b>	UL	Tested and listed under UL916, file number S4804 (QVAX, PAZY).
	CSA	Listing pending.
	FCC	Complies with requirements in FCC Part 15 rules for a Class A Computing Device. Operation in a residential area can cause interference to radio or TV reception and require the operator to take steps necessary to correct the interference.
<b>Q7740A,B FTT Repeaters Q7751A,B Router, Q7752A Serial Adapter</b>	UL	UL1784.
	CSA	Listed.
	FCC	Complies with requirements in FCC Part 15 rules for a Class B Computing Device.

## Abbreviations and Definitions

**AHU**—Air Handling Unit; the central fan system that includes the blower, heating equipment, cooling equipment, ventilation air equipment, and other related equipment.

**CO**—Carbon Monoxide. Occasionally used as a measure of indoor air quality.

**CO<sub>2</sub>**—Carbon Dioxide. Often used as a measure of indoor air quality.

**CARE**—Computer Aided Regulation Engineering; the PC based tool used to configure C-Bus and E-Bus devices.

**C-Bus**—Honeywell proprietary Control Bus for communications between EXCEL 5000® System controllers and components.

**CPU**—Central Processing Unit; an EXCEL 5000® OPEN™ SYSTEM controller module.

**cUL**—Underwriters Laboratories Canada

**CVAHU**—Constant Volume AHU; refers to a type of air handler with a single-speed fan that provides a constant amount of supply air to the space it serves.

**DDF**—Delta Degrees Fahrenheit.

**DDWM**—Digital Display Wall Module.

**D/X**—Direct Expansion; refers to a type of mechanical cooling where refrigerant is (expanded) to its cold state, within a heat-exchanging coil that is mounted in the air stream supplied to the conditioned space.

**E-Bus**—Honeywell implementation of Echelon® LonWorks® network for communication among Excel 10 Controllers.

**E-Bus Segment**—An E-Bus section containing no more than 60 Excel 10s. Two segments can be joined together using a router.

**Echelon®**—The company that developed the LON® bus and the Neuron® chips used to communicate on the E-Bus.

**Economizer**—Refers to the mixed-air dampers that regulate the quantity of outdoor air that enters the building. In cool outdoor conditions, fresh air can be used to supplement the mechanical cooling equipment. Because this action saves energy, the dampers are often referred to as *economizer dampers*.

**EMI**—Electromagnetic Interference; electrical noise that can cause problems with communications signals.

**E-Link**—Refers to the Q7750A Zone Manager. This name is used in internal software and in CARE software.

**EMS**—Energy Management System; refers to the controllers and algorithms responsible for calculating optimum operational parameters for maximum energy savings in the building.

**EEPROM**—Electrically Erasable Programmable Read Only Memory; the variable storage area for saving user

setpoint values and factory calibration information.

**Enthalpy**—The energy content of air measured in BTUs per pound (KiloJoules per Kilogram).

**EPROM**—Erasable Programmable Read Only Memory; the firmware that contains the control algorithms for the Excel 10 Controller.

**Excel 10 Zone Manager**—A controller that is used to interface between the C-Bus and the E-Bus. The Excel 10 Zone Manager also has the functionality of an Excel 100 Controller, but has no physical I/O points.

**NOTE:** The Q7750A Zone Manager can be referred to as E-Link in the internal software, CARE.

**E-Vision**—User interface software used with devices that operate via the FTT E-Bus communications protocol.

**Firmware**—Software stored in a nonvolatile memory medium such as an EPROM.

**Floating Control**—Refers to Series 60 Modulating Control of a valve or damper. Floating Control utilizes one digital output to pulse the actuator open, and another digital output to pulse it closed.

**FTT**—Free Topology Transceiver.

**IAQ**—Indoor Air Quality. Refers to the quality of the air in the conditioned space, as it relates to occupant health and comfort.

**I/O**—Input/Output; the physical sensors and actuators connected to a controller.

**I x R**—I times R or current times resistance; refers to Ohm's Law:  $V = I \times R$ .

**K**—Degrees Kelvin.

**Level IV**—Refers to a classification of digital communication wire. Formerly known as UL Level IV, but *not* equivalent to Category IV cable. If there is any question about wire compatibility, use Honeywell-approved cables (see Step 5 Order Equipment section).

**NEC**—National Electrical Code; the body of standards for safe field-wiring practices.

**NEMA**—National Electrical Manufacturers Association; the standards developed by an organization of companies for safe field wiring practices.

**Node**—A Communications Connection on a network; an Excel 10 Controller is one node on the E-Bus network.

**NV**—Network Variable; an Excel 10 parameter that can be viewed or modified over the E-Bus network.

- PC**—An IBM compatible Personal Computer with 386 or higher processor and capable of running Microsoft® Windows™ Version 3.1.
- Pot**—Potentiometer. A variable resistance electronic component located on the T7770B,C Wall Modules; used to allow user-adjusted setpoints to be input into the Excel 5000 or Excel 10 Controllers.
- PWM**—Pulse Width Modulated output; allows analog modulating control of equipment using a digital output on the controller.
- RTD**—Resistance Temperature Detector; refers to a type of temperature sensor whose resistance output changes according to the temperature change of the sensing element.
- Subnet**—An E-Bus segment that is separated by a router from its Q7750A Zone Manager.
- TOD**—Time-Of-Day; the scheduling of Occupied and Unoccupied times of operation.
- TPT**—Twisted Pair Transceiver.
- VA**—Volt Amperes; a measure of electrical power output or consumption as applies to an ac device.
- Vac**—Voltage alternating current; ac voltage rather than dc voltage.
- VAV**—Variable Air Volume; refers to either a type of air distribution system, or to the W7751 Excel 10 VAV Box Controller that controls a single zone in a variable air volume delivery system.
- VOC**—Volatile Organic Compound; refers to a class of common pollutants sometimes found in buildings. Sources include out-gassing of construction materials, production-line by-products, and general cleaning solvents. A VOC is occasionally used as a measure of indoor air quality.
- W7750**—The model number of the Excel 10 CVAHU Controllers (also see CVAHU).
- W7751**—The model number of the Excel 10 VAV Box Controllers (also see VAV).
- Wall Module**—The Excel 10 Space Temperature Sensor and other optional controller inputs are contained in the T7770 Wall Modules or T7780A DDWM. See Application Step 5. Order Equipment for details on the various models of Wall Modules.
- XBS**—Excel Building Supervisor; a PC based tool for monitoring and changing parameters in C-Bus devices.

## Construction

### Controllers

The Excel 10 W7750 Controller is available in two different models. The W7750A Model, which is a low cost controller made for simple single zone air handlers and heat pump controls. The W7750B Model is intended for more complex applications.

The W7750B Model uses Triacs for its digital outputs, where as the W7750A Model uses dry-contact relays.

All wiring connections to the controller are made at screw terminal blocks. Connection for operator access to the E-Bus is provided by plugging the SLTA connector cable into the E-Bus communications jack.

The W7750A and W7750B Models consist of a single circuit board that is mounted in a sheet metal subbase and protected by a factory snap-on cover. The two controllers have the same physical appearance except for terminals 16 through 20 and different labels next to the wiring terminals (see Fig. 3 or 5). The controllers mount with two screws (see Fig. 4 or 6). Using DIN rail adapters (see Fig. 7) the controllers can also be snapped onto standard EN 50 022 35 mm by 7.5 mm (1-3/8 in. by 5/16 in.) DIN rail. DIN rail is available through local suppliers. If using DIN rail also purchase from Augat Inc. part number 2TK2D DIN rail (adapters) two each for every controller (see Fig. 7). Wires are attached to the screw terminal blocks on both sides of the controller.

A channel in the cover allows the controller status LED to be visible when the cover is in place. There are no field-serviceable parts on the circuit board and, therefore, *it is intended that the cover never be removed.*

The W7750A,B can be mounted in any orientation. Ventilation openings were designed into the cover to allow proper heat dissipation regardless of the mounting orientation. See Fig. 4 and 6.

The input/output and control differences between the two models are summarized in Table 2. The I/O points in Table 2 are the free I/O points that are not reserved for Wall Module use.

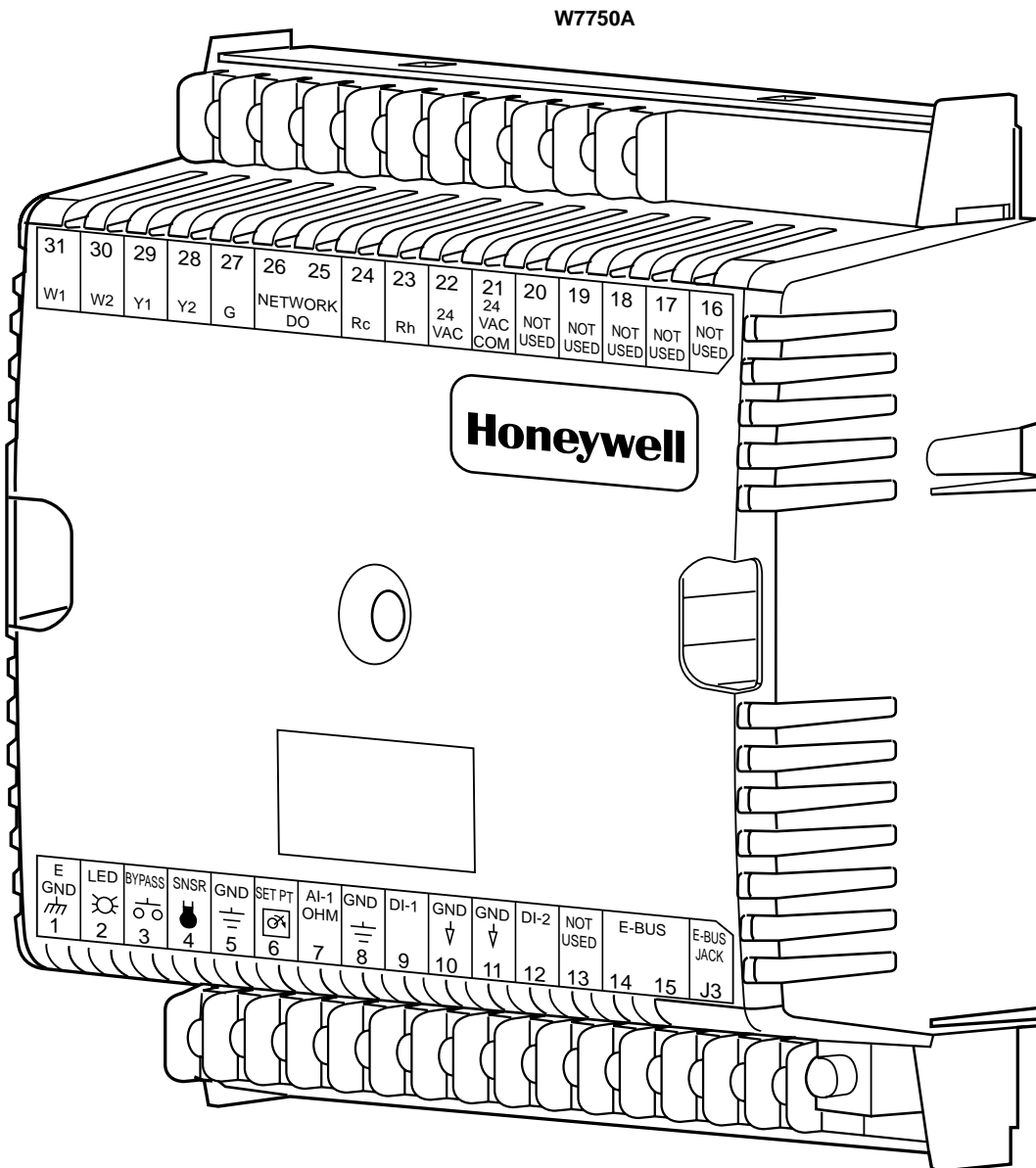
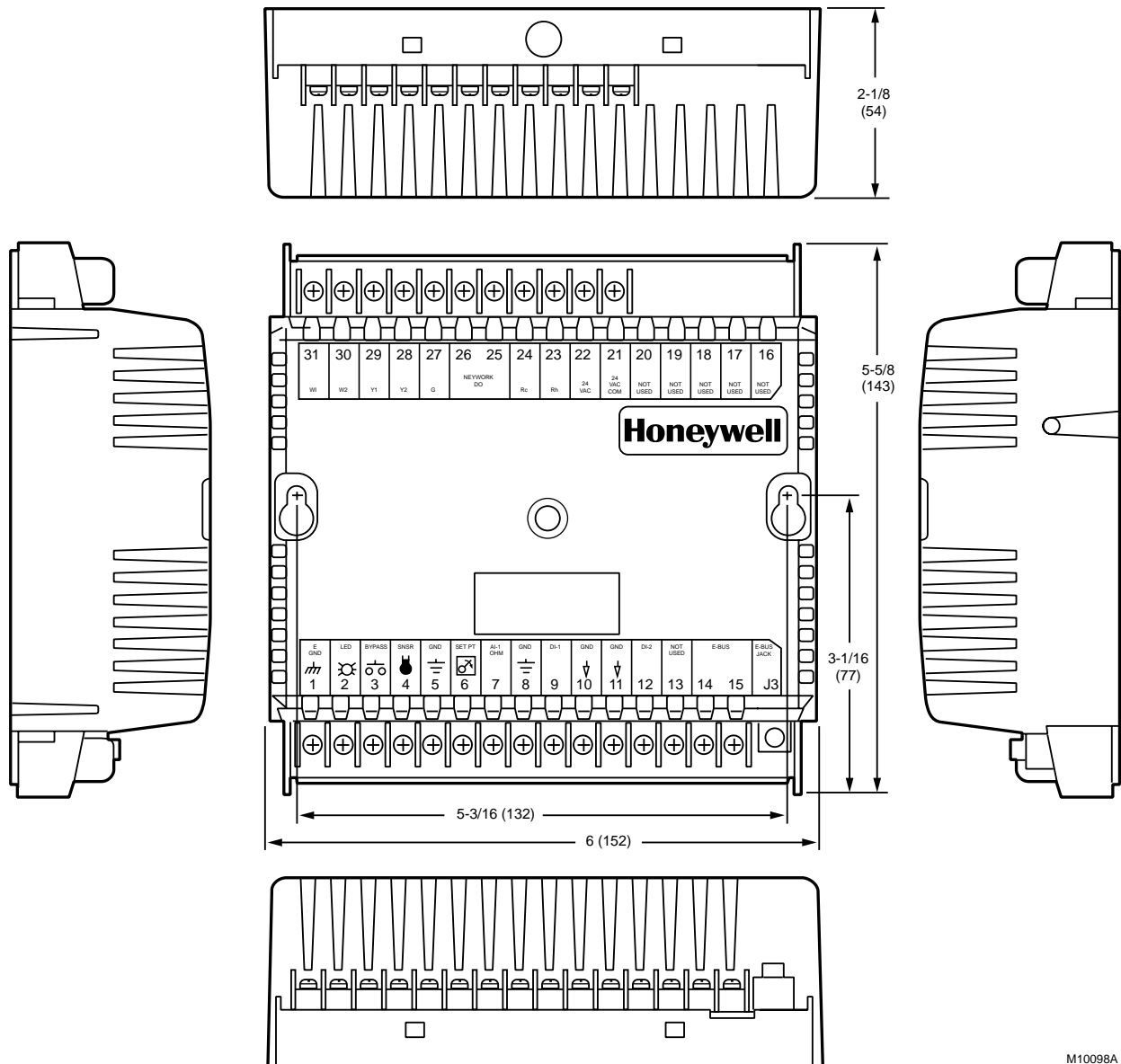

Fig. 3. Excel 10 W7750A Constant Volume AHU Controller.

Table 2. List of Differences in W7750A and W7750B Controllers.

	W7750A Model	W7750B Model
<b>Digital Outputs</b>	6 Relay Outputs	8 Triac Outputs
<b>Digital Inputs</b>	2	4
<b>Wall Module</b>	1*	1*
<b>Analog Inputs</b>	1 (Resistive Input Only)	4 (2 Resistive and 2 Voltage/Current Inputs)
<b>DC Power</b>	None	20 Vdc available to power optional sensors
<b>Floating (Series 60) Control</b>	Economizer Only	Heating, Cooling, and/or Economizer
<b>PWM Control</b>	None	Heating, Cooling, and/or Economizer

\*The T7770 Wall Modules includes I/O points for two analog inputs for the space temperature and the setpoint knob, a digital input for the Bypass pushbutton, and a digital output for the LED Bypass Indicator. These W7750 I/O points are configurable, but are normally used for the Wall Module.



M10098A

Fig. 4. W7750A construction in in. (mm).

#### Performance Specifications

##### Power:

24 Vac with a minimum of 20 Vac and a maximum of 30 Vac at either 50 or 60 Hz. The W7750A,B power consumption is 6 VA maximum at 50 or 60 Hz. The W7750A,B is a NEC Class 2 rated device. This listing imposes limits on the amount of power the product can consume or directly control to a total of 100 VA.

##### Special Note for the W7750B Unit:

The individual Triac outputs incorporate an internal common connection with the input power transformer. The Triacs provide a switched path from the hot side (R) of the transformer through the load to the common of the transformer. The W7750B Controller design *must* use the same power transformer for any loads connected to that controller; see Fig. 28.

Each individual Triac is rated 1A at 30 Vac maximum. Under all operating conditions, the maximum load/source power budget for the W7750B Controller is 100 VA. Actual allowable Triac current is 500 mA MAX.

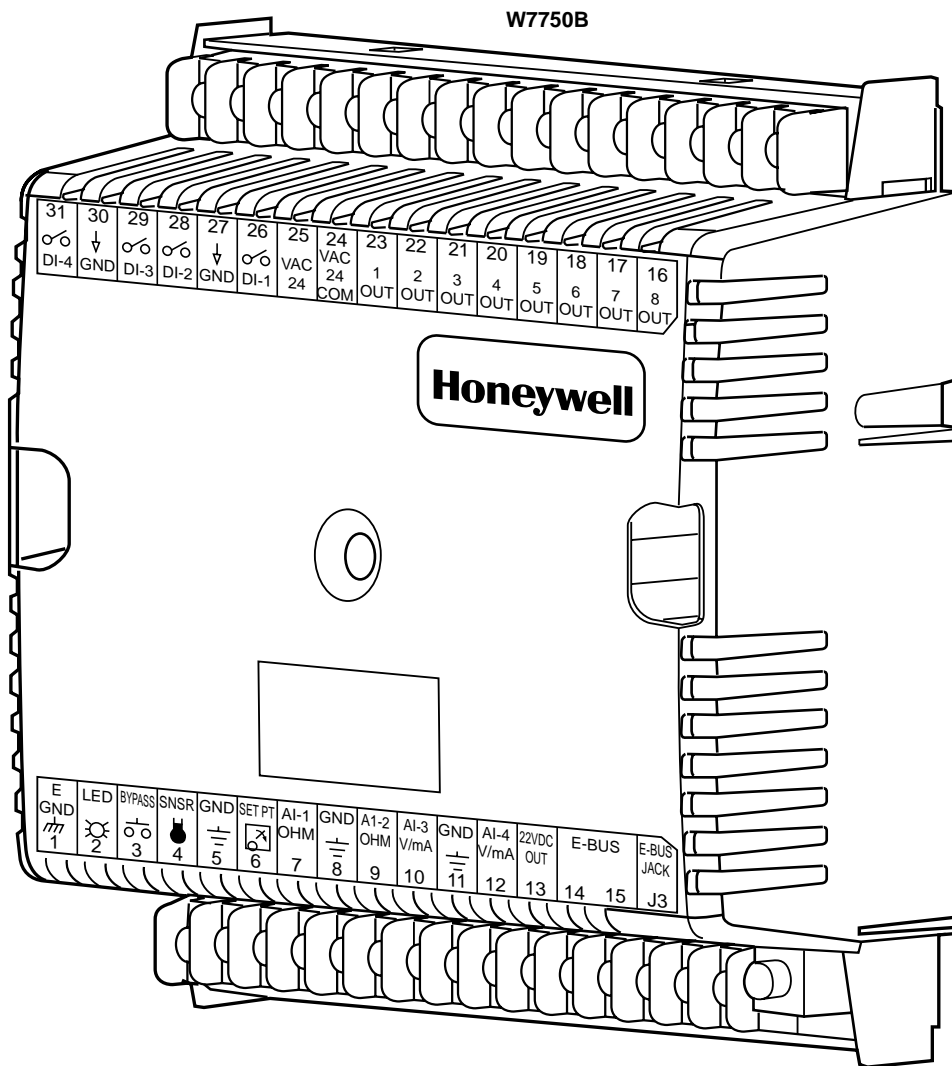

M15118

Fig. 5. Excel 10 W7750B Constant Volume AHU Controller.

**CPU:**

Motorola or Toshiba 3150 Neuron™ processor, containing three eight-bit CPUs. Each Neuron has a unique 48-bit network identification number.

**Memory Capacity:**

64K ROM/PROM (6K reserved for network operations, 58K usable for control algorithm code).  
 512 bytes EEPROM.  
 2K RAM.

**Specified Space Temperature Sensing Range:**

45 to 99°F (7 to 37°C) with an allowable control setpoint range from 50 to 90°F (10 to 32°C) when initiated from the network and 55 to 85°F (13 to 29°C) when configured and connected to T7770 Wall Modules or T7780A DDWM.

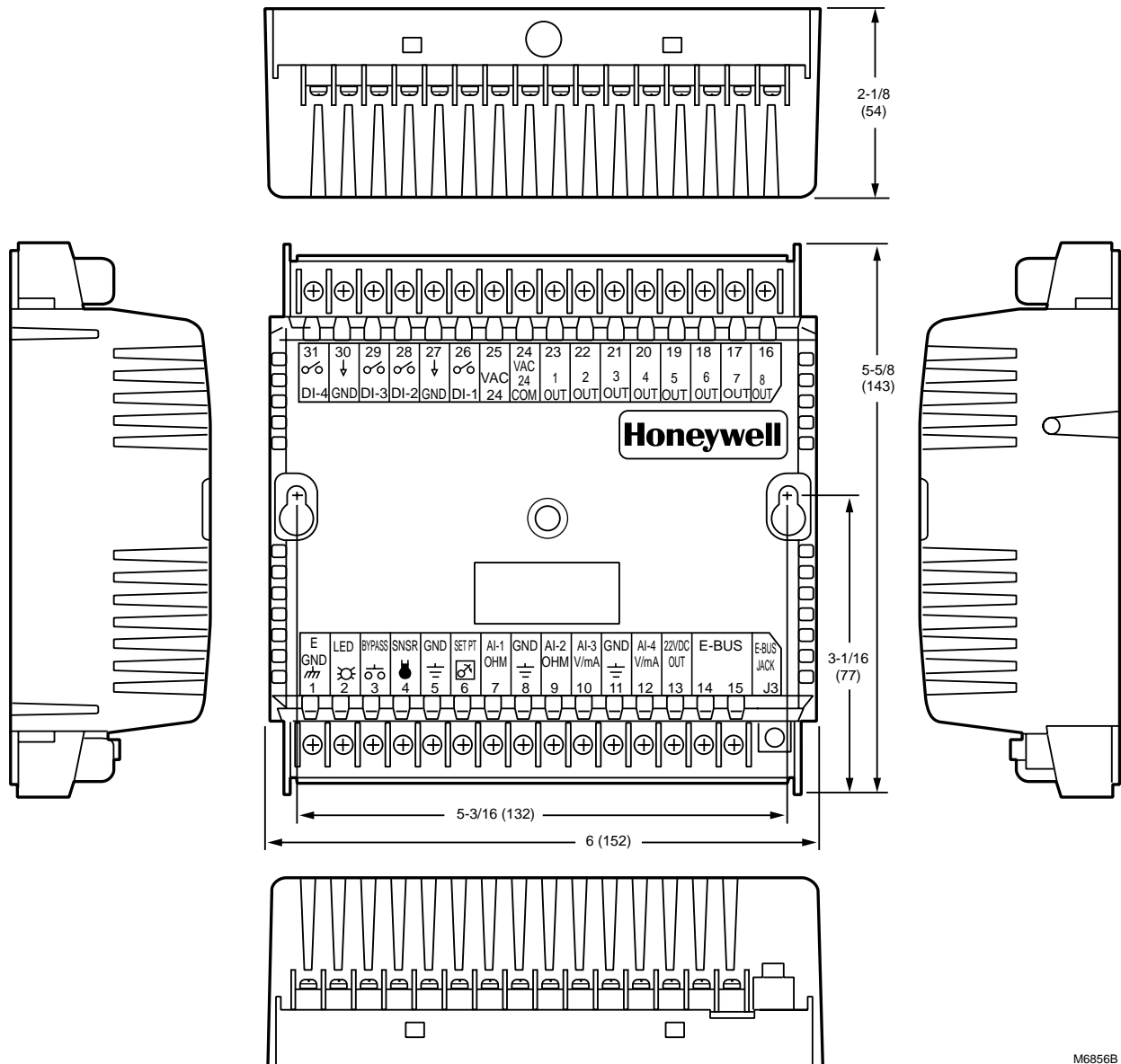

M6856B

Fig. 6. W7750B construction in in. (mm).

**Communications:**

The W7750A,B Controller uses an Free Topology Transceiver (FTT) transformer-coupled communications port running at 78 kilobits per second (kbs). Using the transformer-coupled communications interface offers a much higher degree of common-mode noise rejection while ensuring dc isolation.

Approved cable types for E-Bus communications wiring is Level IV 22 AWG (0.34 mm<sup>2</sup>) plenum or nonplenum rated unshielded, twisted pair, solid conductor wire. For nonplenum areas, use Level IV 22 AWG (0.34 mm<sup>2</sup>) such as US part AK3781 (one pair) or US part AK3782 (two pair). In plenum areas, use plenum-rated Level IV, 22 AWG (0.34 mm<sup>2</sup>) such as US part AK3791 (one pair) or US part AK3792 (two pair). (See Tables 9 and 11 for part numbers.) Contact Echelon® Corp. Technical Support for the recommended vendors of Echelon® approved cables.

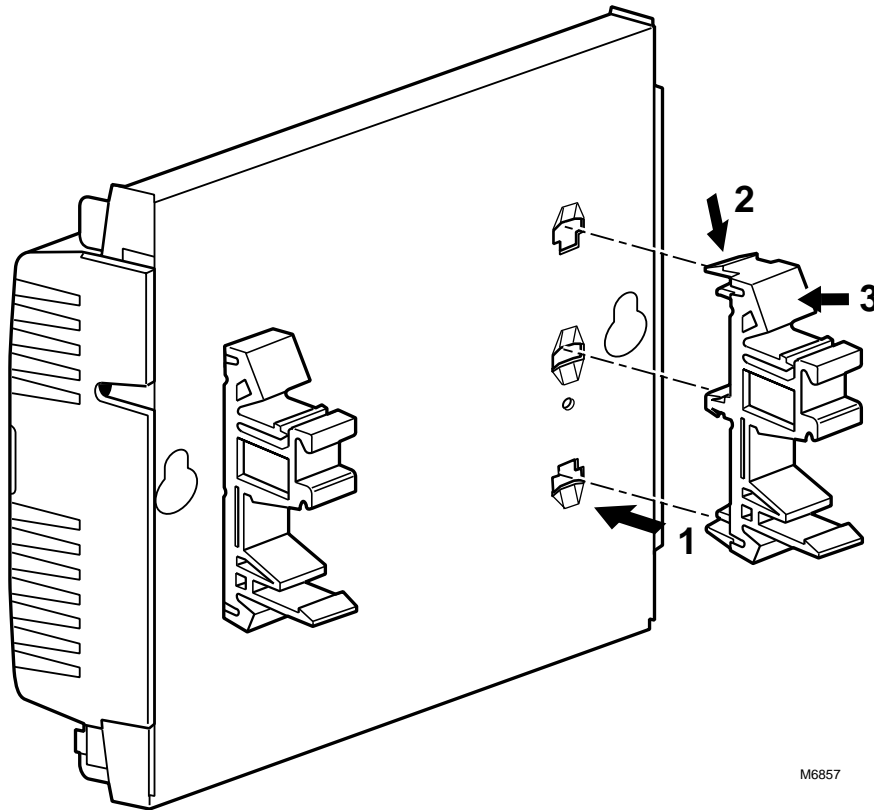

Fig. 7. DIN rail adapters.

The FTT supports polarity insensitive free topology wiring. Freeing the system installer from the need to wire using a bus topology. Star, bus, mixed, and loop wiring are all supported by this architecture. The maximum E-Bus length when using a combination of star, loop, and bus wiring (singly terminated) is 1640 ft (500m) with the maximum node-to-node length of 1312 ft (400m). In the event that the total wire length is exceeded, then a Q7740A 2-Way Repeater or a Q7740B 4-Way Repeater can be used to allow the number of devices to be spread out as well as increasing the length of wire over which they communicate. The maximum number of repeaters per segment is one (on either side of the router). A Q7751A,B E-Bus Router can also be used to effectively double the maximum E-Bus length. The advantage of using the router is that it will segregate traffic to a segment while when using the repeater, all traffic is repeated on each segment. When utilizing a doubly terminated E-Bus structure, use a continuous daisy-chain with no stubs or taps from the main backbone, The maximum E-Bus length is 4593 ft (1400m) with the maximum node-to-node length of 3773 ft (1150m).

FTT networks are very flexible and convenient to install and maintain, but it is imperative to carefully plan the network layout and create and maintain accurate documentation. This will aid in compliance verification and future expansion of the FTT network. This will also keep unknown or inaccurate wire run lengths, node-to-node (device-to-device) distances, node counts, total wire length, inaccurate repeater/router locations, and misplaced or missing terminations minimized. Refer to E-Bus Wiring Guidelines form, 74-2865 for complete description of network topology rules.

#### LonMark® Functional Profile

W7750 Controllers support the LonMark® Functional Profile number 8030 Roof Top Unit Controller, version 1.0 (see Fig. 8).

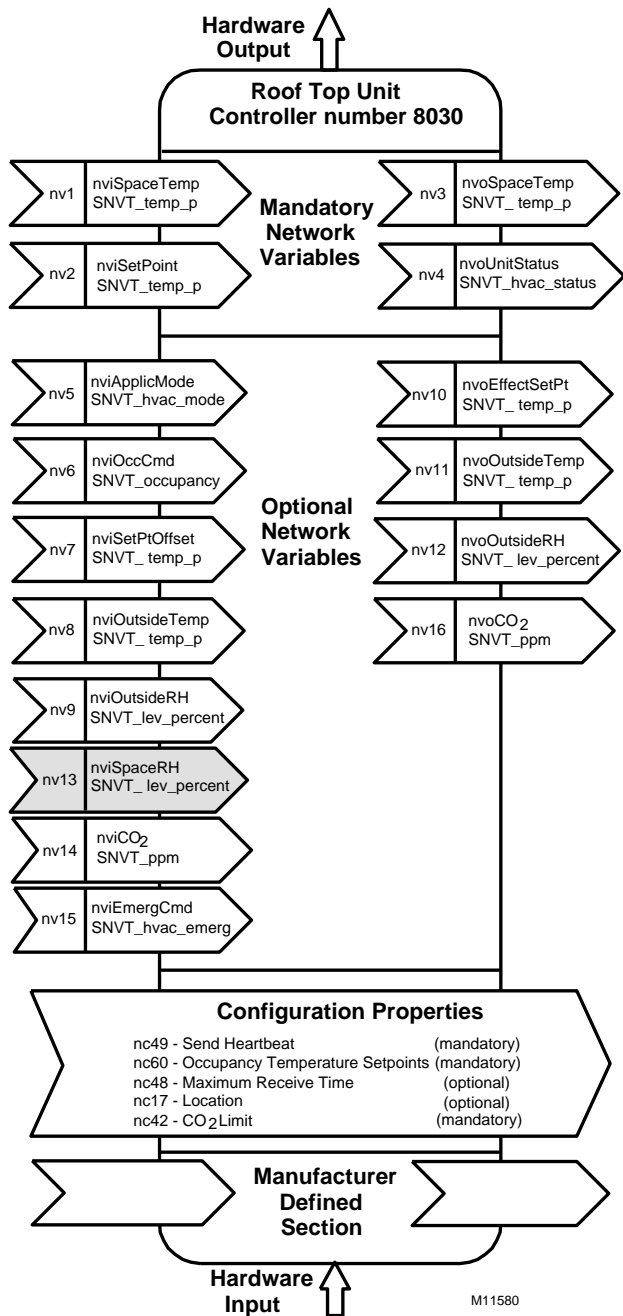

Fig. 8. Functional profile of LonMark® RTU object details (variables not implemented in Excel 10 CVAHU are greyed).

**Environmental:**

Operating Temperature: -40 to 150°F (-40 to 65.5°C).

**Shipping Temperature:**

-40 to 150°F (-40 to 65.5°C).

**Relative Humidity:**

5% to 95% noncondensing.

**Vibration:**

Rated V2 level compliant.

**Inputs/Outputs:**

The W7750A Unit supports the following hardware features:

- Three 20 Kohm NTC (1000 through 150,000 ohm) or PT3000 (250 through 12,000 ohm) resistive analog inputs (one reserved for space temperature and one reserved for the setpoint knob).
- Three dry contact digital inputs (one reserved for the Bypass pushbutton).
- LED digital output (*only* for the wall module LED) 2.5V at 3 mA.
- Six 24 Vac relay digital outputs (1.5A relays rated at 7.5A inrush current).

The W7750B Unit supports the following hardware features:

- Four 20 Kohm NTC (1000 through 150,000 ohm) or PT3000 (250 through 12,000 ohm) resistive analog inputs (one reserved for space temperature and one reserved for the setpoint knob).
- Two 0.2 to 10 VDC or 2 to 20 mA (user selectable) analog inputs.
- Five dry contact digital inputs (one reserved for the Bypass pushbutton).
- Eight 24 Vac Triac digital outputs (500 mA MAX).
- LED digital output (*only* for the wall module LED) 2.5V at 3 mA.
- One 22 Vdc power supply for auxiliary devices with a maximum current of 50 mA.

**Analog Inputs:**

**Space Temperature:**

Type: RTD.  
Supported Sensors: T7770A,B,C,D; T7780A.

**Discharge Air Temperature:**

Type: RTD.  
Supported Sensors: C7100A1015\*, C7770A1006, C7031B1033, C7031C1031, C7031D1062, C7031F1018, C7031J1050, C7031K1017.

**Outdoor Air Temperature:**

Type: RTD.  
Supported Sensors: C7170A1002.

**Return Air Temperature:**

Type: RTD.  
Supported Sensors: C7100A1015\*, C7770A1006, C7031B1033, C7031C1031, C7031D1062, C7031F1018, C7031J1050, C7031K1017.

\*The PT3000 sensor is not recommended for floating control (real time - discharge or return configured as space sensor). The PT3000 sensor is intended for monitoring or differential (staged) control

**Outdoor Air Humidity (W7750B only):**

Type: Voltage/Current.

Supported Sensors: C7600B1000 and C7600B1018 (2 to 10V), C7600C1008 (4 to 20mA).

**Return Air Humidity (W7750B only):**

Type: Voltage/Current.

Supported Sensors: C7600B1000 and C7600B1018 (2 to 10V), C7600C1008 (4 to 20mA).

**Outdoor Air Enthalpy (W7750B only):**

Type: Current.

Supported Sensors: C7400A1004 (4 to 20mA).

**Return Air Enthalpy (W7750B only):**

Type: Current.

Supported Sensors: C7400A1004 (4 to 20mA).

**Air Filter Differential Pressure (W7750B only):**

Type: Voltage.

Supported Sensors: Third party 2 to 10V, 0 to 5 inw (1.25 kPa) differential pressure sensors.

**CO<sub>2</sub> Sensor (W7750B only):**

Type: Voltage.

Supported Sensors: Third party 0 to 10V, 0 to 2000 ppm CO<sub>2</sub> sensors.**Monitor Sensor for network use (W7750B only):**

Type: Voltage.

Supported Sensors: Third party 2 to 10V, 2 to 10 volts displayed.

**Digital Inputs:**

Dry-contact inputs are sensed using a 9 milliamp at 4.8 volts detection circuit. It is very important that the device used contains high quality, noncorroding contacts with resistivity that does not degrade; that is, increase over time. Use noble metal (such as gold or silver), or pimpled or sealed contacts to assure consistent, long-term operation.

Two of the following Digital Inputs (DIs) can be configured when using the W7750A, and four of the following when using the W7750B:

- Fan Status:  
Contact Closed = Fan on
- IAQ Switch:  
Contact Closed = Poor Air Quality
- Time Clock:  
Contact Closed = Occupied Mode; Contact Open = Unoccupied Mode

- Schedule Master:  
Contact Closed = Local time clock is used as master time clock
- Economizer Enable Signal:  
Contact Closed = Economizer Enabled for cooling use
- Smoke Monitor:  
Contact Closed = Smoke Detected
- Dirty Filter:  
Contact Closed = Dirty Filter
- Shutdown Signal:  
Contact Closed = Shut off all equipment
- Occupancy Switch:  
Contact Closed = Room is Occupied; Contact Open = Room is Unoccupied
- Window Monitor:  
Contact Closed = Window is Closed
- Wall Module Bypass Pushbutton:  
Momentary DI (See Appendix B—Sequences of Operation for bypass details.)

**Triac Outputs (W7750B only):****Triac Outputs on the W7750B Model:**

- Power ratings: 20 Vac to 30 Vac at 25 mA MIN to 500 mA MAX current for any voltage.

**CAUTION**

When any device is energized by a Triac, the device must be able to sink a minimum of 25 mA.

NOTE: Triacs sink current to the 24 Vac common (COM terminal on the W7750B Model); see Fig. 28 for wiring example.

**IMPORTANT**

*If non-Honeywell motors, actuators, or transducers are to be used with Excel 10 Controllers, Triac compatibility must be verified (see previous NOTE).*

**Wall Modules**

The T7770 Wall Modules for the Excel 5000 and Excel 10 Controllers are available in a variety of configurations. The models T7770A1006 and T7770C1002 are shown in Fig. 9. The T7770B,D are the same physical size (see Product Names section for differences).



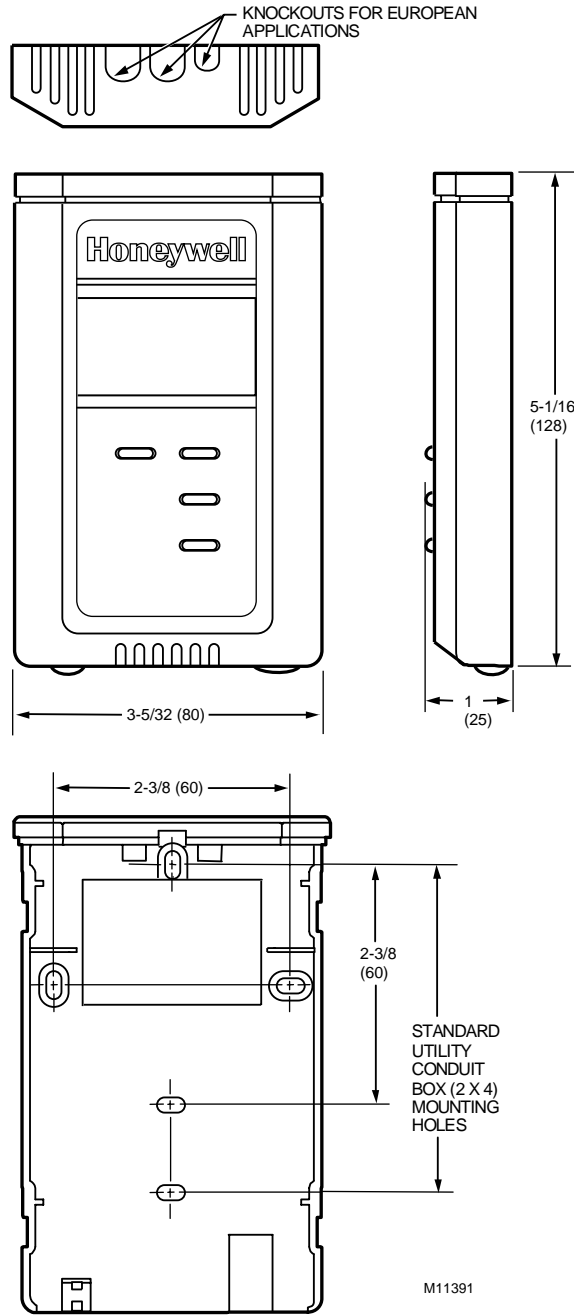

Fig. 10. T7780A construction in in. (mm).

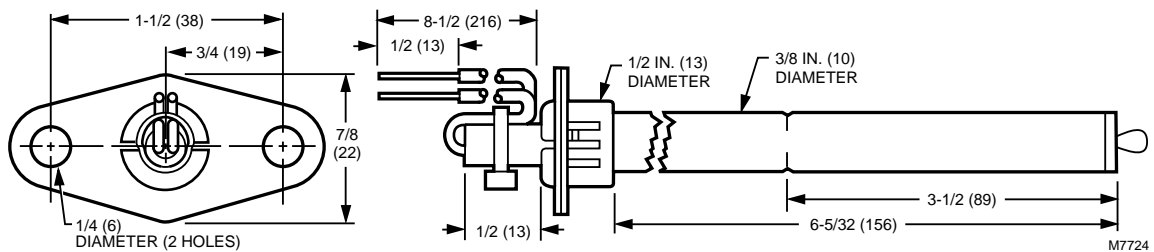

Fig. 11. C7770A construction in in. (mm).

## Configurations

### General

Tables 3 and 4 provide an overview of the Excel 10 W7750 configuration options. All W7750s are assumed to have a supply fan digital output. Additionally, Tables 3 and 4 list the general mechanical equipment options available with the W7750 Controller. See Application Step 6. Configure Controllers, for further information on configurations.



## CAUTION

For floating control, the Excel 10 W7750 Controller is designed to work only with Series 60 valve and damper actuators. Full stroke actuator drive-time must be between 20 and 240 seconds (0.25 to 4.0 minutes).

**Table 3. Common Configuration Options Summary For Both W7750A And W7750B Controllers.**

Option	Possible Configurations Common to Both W7750 Models
<b>Supply Fan Type of Air Handler</b>	1. Mandatory Digital Output.
	2. Conventional.
	3. Heat Pump.
<b>Occupancy Sensor</b>	1. None.
	2. Connected: Contacts closed equals Occupied.
	3. Network (Occ/Unocc signal received via the E-Bus network).
<b>Window Sensor</b>	1. None.
	2. Physically Connected: Contacts closed equals window closed.
	3. Network (Window Open/Closed signal received via the E-Bus).
<b>Wall Module Option</b>	1. Local (direct wired to the controller).
	2. Network (sensor value received via the E-Bus).
<b>Wall Module Type</b> (All four types have an E-Bus access jack)	1. Sensor only.
	2. Sensor and Setpoint adjust.
	3. Sensor, Setpoint adjust and Bypass.
	4. Sensor and Bypass.
<b>Smoke Emergency Initiation</b>	1. None.
	2. Physically Connected: Contacts closed equals smoke detected.
	3. Network (Emergency/Normal signal received via the E-Bus).

**Table 4. Configuration Options Summary For W7750A And W7750B Controllers.**

Option	Possible Configurations for the W7750A Model	Possible Configurations for the W7750B Model
Type of Heating	1. One stage.	1. One stage.
	2. Two stages.	2. Two stages.
	3. Three stages.	3. Three stages.
	4. Four stages.	4. Four stages.
	5. None.	5. Series 60 Modulating electric valve, or pneumatic via transducer.
		6. Pulse Width Modulating electric valve, or pneumatic via transducer.
		7. None.
Type of Cooling	1. One stage.	1. One stage.
	2. Two stages.	2. Two stages.
	3. Three stages.	3. Three stages.
	4. Four stages.	4. Four stages.
	5. None.	5. Series 60 Modulating electric valve, or pneumatic via transducer.
		6. Pulse Width Modulating electric valve, or pneumatic via transducer.
		7. None.
Type of Economizer	1. Digital Output Enable/Disable signal for controlling an external economizer package.	1. Digital Output Enable/Disable signal for controlling an external economizer package.
	2. Series 60 Modulating electric damper motor, or pneumatic via transducer.	2. Series 60 Modulating electric damper motor, or pneumatic via transducer.
	3. None.	3. Pulse Width Modulating electric damper motor, or pneumatic via transducer.
		4. None.
IAQ Option	1. None.	1. None.
	2. Local IAQ Digital Input—directly wired to the controller. (Contacts closed means poor IAQ is detected.)	2. Local IAQ Digital Input—directly wired to the controller. (Contacts closed means poor IAQ is detected.)
	3. Network (IAQ Override signal received via the E-Bus).	3. Network (IAQ Override signal received via the E-Bus).
		4. Local CO <sub>2</sub> Analog Input—directly wired to the controller. (The sensor must be a 0 to 10V device representing 0 to 2000 PPM CO <sub>2</sub> .)
Filter Monitor Option	1. None.	1. None.
	2. Local Dirty Filter Digital Input—directly wired to the controller. (Contacts closed means that the filter is dirty.)	2. Local Dirty Filter Digital Input—directly wired to the controller. (Contacts closed means that the filter is dirty.)
		3. Local Analog Input for Differential Pressure across the Filter (directly wired to the controller). The sensor must be a 2 to 10V device representing 0 to 5 inw (1.25 kPa).

### Allowable Heating and Cooling Equipment Configurations

Each W7750 device can control a variety of different types of mechanical cooling and heating equipment within roof top air handlers. See Fig. 17 through 21 for a conceptual overview of some typical configurations. For specific wiring details, see the Prepare Wiring Diagrams section.

**Staged Heating/Cooling Control**

Staged equipment control is available for up to four stages of heating or four stages of cooling. On the W7750, the stages are activated through digital outputs (Triacs on the W7750B, dry-contact relays on the W7750A), one for each stage, wired to 24 Vac contactors (see Fig. 25 and 28 in Step 4. Prepare Wiring Diagrams section for wiring details). Note that the number of physical Digital Outputs (DOs) on the controller limits the total number of stages that can be controlled. For example, the W7750A Model has six digital outputs, and because one is used for the supply fan, there are five DOs available for any combination of heating and cooling stages (with a maximum of four stages of heating and four stages for cooling). The W7750B Model offers two additional DOs, for a total of eight. Fig. 12 shows a typical application of two stages of heat and two stages of cooling.

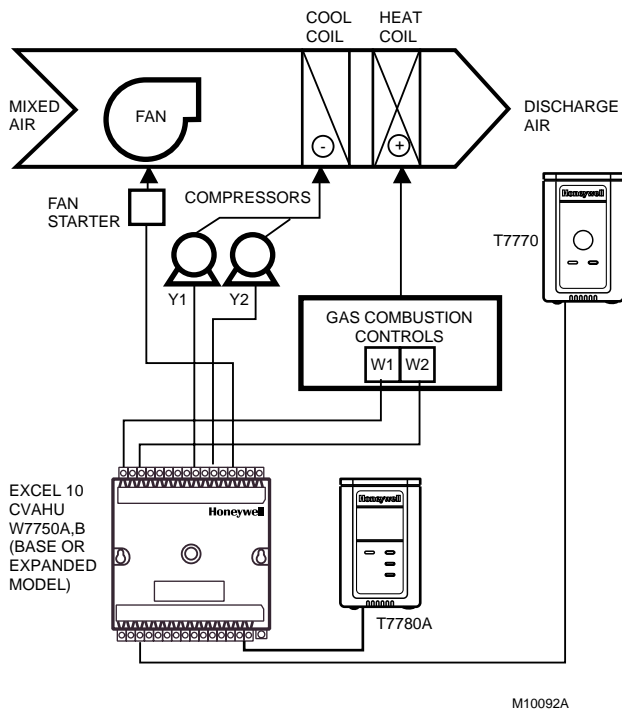
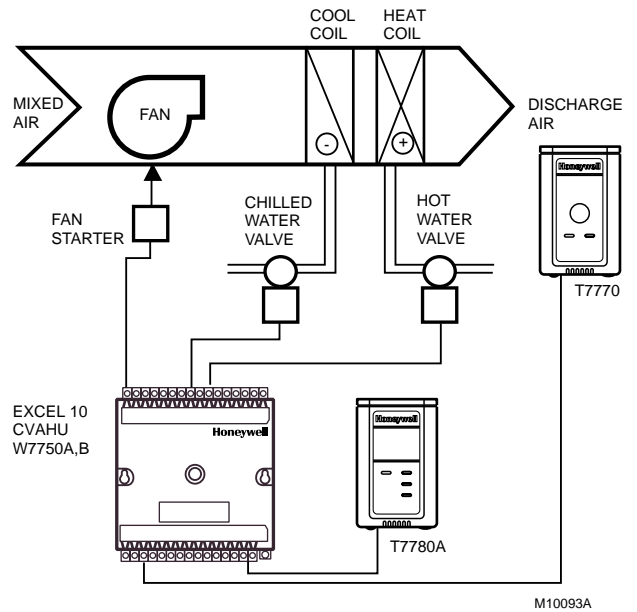

**Fig. 12. Fan with two stages of heating and two stages of cooling.**

**Modulating Heating/Cooling Control**

The W7750 Controller provides modulating equipment control for heating and cooling equipment (and economizer dampers, see Fig. 15) using either Series 60 Floating Control or Pulse Width Modulated (PWM) control, (PWM control is available on the W7750B only). The Series 60 Modulating Control is provided through two Relay digital outputs on the W7750A or two Triac digital outputs on the W7750B, one to pulse the valve actuator open and one to pulse it closed. PWM control positions the actuator based on the length, in seconds, of the pulse from the digital output. For PWM, the controller outputs a pulse whose length consists of two parts, a minimum and a maximum. The minimum pulse time represents the analog value of 0 percent and the maximum pulse length that represents an analog value of 100 percent. If the analog value is greater than 0 percent, an additional

time is added to the minimum pulse time. The length of time added is directly proportional to the magnitude of the analog value. The PWM actuator will begin to use the analog value at the end of the pulse and will continue to use this value until a new pulse is received. Refer to appendix B under PWM Control for an example. Series 60 actuators are generally less expensive than those for PWM, but the trade-off is that PWM requires only a single controller digital output while floating control uses two DOs. Refer to appendix B under Series 60 Modulating Control for an example. Fig. 13 illustrates a system with modulating heating and cooling (see Fig. 25 and 29 in Step 4. Prepare Wiring Diagrams section, for wiring details).

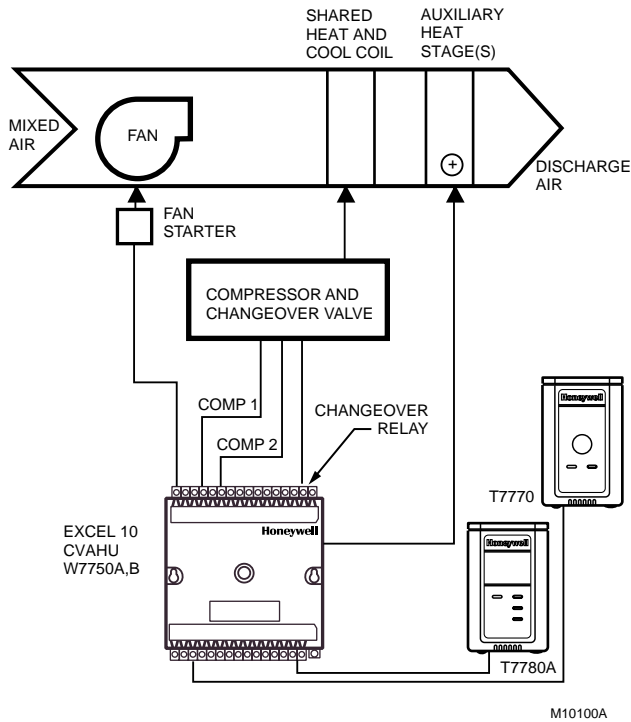

**Fig. 13. Fan, modulating heating and modulating cooling.**

**NOTE:** Pneumatically actuated valves can be controlled using a pneumatic transducer device. See Fig. 16. Also, transducer devices are available from third party vendors to convert PWM outputs to a voltage or current signal if desired.

**Heat Pump Control**

The W7750 Controller handles heat pump applications similarly to staged heating/cooling control. Heat pump applications are supported by providing outputs for up to four compressor stages, a change-over relay for the refrigerant reversing valve, and up to four stages of auxiliary heat. Note that the W7750A Model has six digital outputs, and therefore, with one DO used for the supply fan and one for the change-over relay, there are four outputs available for any combination of compressors and auxiliary heat stages. The W7750B Model offers two additional DOs for a total of eight. Fig. 14 illustrates a typical heat pump system with auxiliary heat (see Fig. 25 and 29 in Step 4. Prepare Wiring Diagrams section for wiring details).



M10100A

Fig. 14. Heat pump with two compressors and auxiliary heat stage(s).

**Economizer Control**

Economizer control is available concurrently with any configuration in the W7750 when DOs are not all used by the heating and cooling equipment. Two types of economizer controls are supported by the W7750 Controller, modulating control and enable/disable control. Modulating control can be either Series 60 Floating Control or PWM control (PWM control is available on the W7750B only). A discharge air temperature sensor is required for modulating economizer damper control. Enable/disable control is provided to emulate the Honeywell T7300 thermostat economizer operation, where a DO tracks the occupancy status of the controller. An external packaged economizer control then modulates the dampers. For modulating control, the economizer is enabled or disabled based on one of ten available strategies (see Appendix B—Sequences of Operation—Economizer Enable/Disable Control section, for further details). Fig. 15 illustrates a system with modulating economizer dampers (see Fig. 27, 29 and 30 in Step 4. Prepare Wiring Diagrams section, for wiring details).

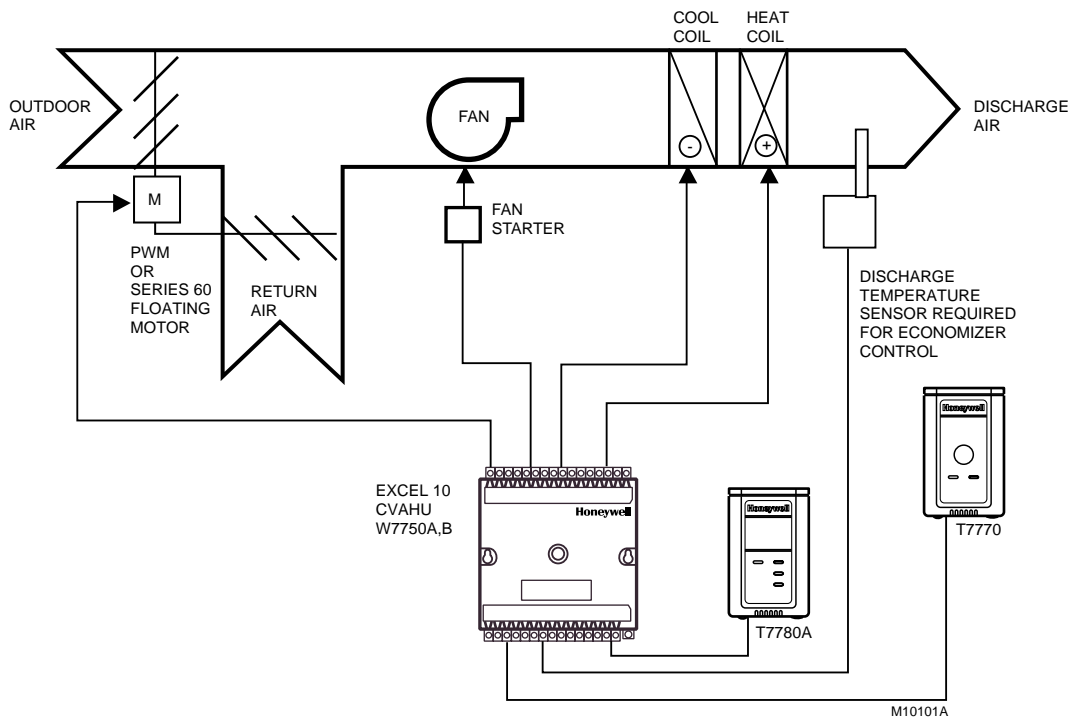

M10101A

Fig. 15. Economizer control.

**Pneumatic Actuator Control**

The W7750B Controller can control pneumatic actuators for any or all of the three modulating outputs provided by the control algorithm (heat, cool and economizer). Control of

pneumatic water/steam valves and damper actuators is provided through a transducer device using either Series 60 Floating Control or PWM DOs. A floating-to-pneumatic, or a PWM-to-pneumatic transducer is required for each output signal. The W7750A Controller can only be configured to use

Series 60 Floating Control for the modulating economizer output and must use staged outputs for heating and cooling control. There are no PWM outputs configurable on the W7750A model.

For projects with existing pneumatically actuated reheat valves, the Excel 10 W7750 Controller output must be converted to a pneumatic signal using a transducer device developed for use with Excel 10 Controllers. The transducer is available through Honeywell, or directly from the manufacturer, Mamac Systems (see Table 11 for ordering information).

Fig. 16 depicts a typical W7750 System with modulating heating valve using a pneumatic valve actuator. Also see Fig. 33 for wiring an MMC325 Pneumatic Transducer to a W7750A,B Controller.

**NOTE:** When choosing the pneumatic pressure range, make sure that the closeoff pressure is 2 to 3 psi greater than that of the spring range. When using a spring range of 5 to 10 psi with 10 psi as the closed position, *do not* use the 0 to 10 psi model of the MMC325 Transducer; use the 0 to 20 psi transducer as the recommended selection.

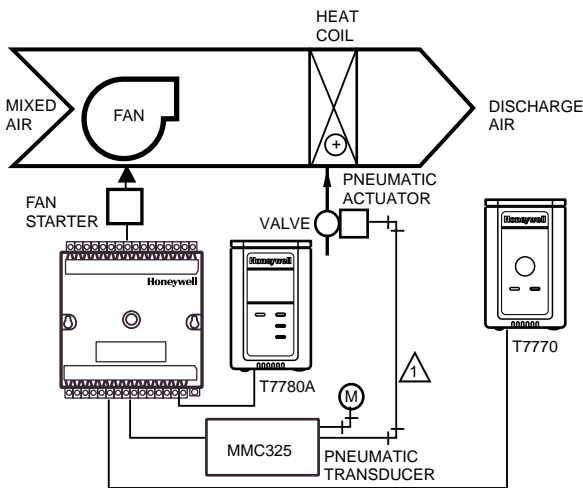

1 PNEUMATIC MAIN OR BRANCH LINE MUST BE 1/4 IN. (6 MM) OR LARGER TUBING. A MINIMUM OF 6 FT (1.8M) OF TUBING IS NEEDED IN A BRANCH LINE.

M10096A

Fig. 16. Modulating heat with pneumatic valve actuator.

### Mixed-Output-Type Control

The W7750B Controller provides control for mixed-output-types of applications such as PWM heating and staged cooling control occurring simultaneously with Series 60 Floating Economizer Damper Control.

### Occupancy Sensor

Excel 10 W7750 Controllers provide a digital input for connection to an occupancy sensor. This is a device, such as a passive infrared motion detector, that contains a dry contact (see following NOTE) closure to indicate whether or not people are present in the space. The Excel 10 W7750 Controller expects a contact closure to indicate the space is Occupied. See Fig. 25 through 32 in Application Step 4, Prepare Wiring Diagrams, for details on wiring connections.

The control algorithm in the Excel 10 Controller uses the occupancy sensor, if configured, to determine the Effective Occupancy (see Table 5) mode of operation. If the Time Of Day (TOD) schedule indicates an Occupied state, and the occupancy sensor contact is closed, the Effective Occupancy mode is Occupied. However, if the TOD schedule indicates an Occupied state and the occupancy sensor contact is open, then the Effective Occupancy mode is STANDBY. The temperature control algorithm is then controlled to the STANDBY Cooling and Heating Setpoints.

If the occupancy sensor is not configured, a local controller can be put in the STANDBY mode only by either a one-to-one association of the occupancy sensor from another Excel 10 Controller to the local controller, or by receiving the STANDBY mode signal via the E-Bus.

**NOTE:** The Excel 10 Controller has limited power available (only 9 mA at 4.8 volts) for checking the digital inputs for contact closures. It is very important that the device used contains high quality, noncorroding contacts with resistivity that does not degrade; that is, increase over time. Use noble metal (such as gold or silver), or pimpled or sealed contacts to assure consistent, long-term operation.

The recommended devices for use with the Excel 10 W7750 Controllers are the EL7628A1007 Ceiling Mounted Infrared or the EL7680A1008 Wall Mounted Wide View Infrared Occupancy Sensors. If ultrasonic sensors are required, the EL7611A1003 and the EL7612A1001 Occupancy Sensors are recommended. An EL76XX Power Supply/Control Unit is required for use with these occupancy sensors. The EL7630A1003 can power up to four sensors, and is multi-tapped for several line voltages. The EL7621A1002 can power three sensors and it connects to 120 Vac line voltage. The EL7621A1010 can also power three sensors but it connects to 277 Vac line voltage.

## Window Open/Closed Digital Input

A digital input is also provided for detecting whether a window in the space was opened. The Excel 10 W7750 Controller can be connected to a dry contact (see the following NOTE and Fig. 25 through 32 in Application Step 4. Prepare Wiring Diagrams, for details) or a set of contacts wired in series (for monitoring multiple windows) to verify that the window(s) are closed. The algorithm expects a contact closure to indicate the window is closed. If an open window is detected, the algorithm changes the mode of operation to FREEZE\_PROTECT, which shuts down the control functions, and watches for low space temperature conditions. The frost protection setpoint is 46.4°F (8°C), and the frost alarm occurs at 42.8°F (6°C).

**NOTE:** (This is the same NOTE as in the Occupancy Sensor section.) The Excel 10 has limited power available (only 9 mA at 4.8 volts) for checking the digital inputs for contact closures. It is very important that the device used contains high quality, noncorroding contacts with resistivity that does not degrade; that is, increase over time. Use noble metal (such as gold or silver), or pimpled or sealed contacts to assure consistent, long-term operation.

## Wall Module Options

As previously discussed, there are four basic varieties of the T7770 Wall Modules and one of the T7780A DDWM (see the Product Names and the Construction sections). Also, a T7770 Wall Modules and T7780A can be shared among two or more W7750s. The control algorithm must be given this wall module information when configuring the W7750 (see Excel E-Vision User's Guide, form 74-2588).

## Dirty Filter Monitor

The air filter in the air handler can be monitored by the W7750 and an alarm issued when the filter media needs replacement. The two methods of monitoring the filter are:

1. Connecting a differential pressure switch to a digital input on the W7750A or W7750B.

2. Wiring a 2-to-10V differential pressure sensor to a voltage input on the W7750B. If the analog input sensor is used, its measured value 0 to 5 inw (0 to 1.25 kPa) is compared to a user-selectable setpoint (FltrPressStPt—valid range: 0 to 5 inw (0 to 1.25 kPa)), and the Dirty Filter alarm is issued when the pressure drop across the filter exceeds the setpoint.

## Indoor Air Quality (IAQ) Override

The Excel 10 W7750 Controller provides IAQ ventilation control using one of two different methods of detecting poor air quality. The first is with an IAQ switch device connected to a digital input on the W7750 Controller, where a contact closure indicates poor air quality, and initiates the IAQ Override mode. The device can detect poor air quality using any desired measure such as CO<sub>2</sub>, VOC, CO, etc. The second method, which is only available on the W7750B, is through an analog input that connects to a CO<sub>2</sub> sensor (0 to 10V). The measured value of CO<sub>2</sub> from this sensor (0 to 2000 PPM) is compared to the setpoint (IAQSetpt). When the CO<sub>2</sub> level is higher than the setpoint, the IAQ Override is initiated.

The effect of initiating the IAQ Override mode is that the economizer dampers are allowed to open above the standard minimum position setting to allow more fresh air to enter the building. See Appendix B—Sequences of Operation, for further control details.

## Smoke Control

The Excel 10 W7750 Controller supports smoke-related control strategies that are initiated either via a network command (DestEmergCmd) or from a local (physically connected) smoke detector digital input. The details of the W7750 smoke-related control operation are described in Appendix B—Sequences of Operation.

## Modes of Operation

The possible modes of operation for the W7750 Controller are listed in Table 5.

**Table 5. Modes Of Operation For The Excel 10 W7750 Controller.**

Mode	Description	Events causing a controller to switch to this mode
<b>Effective Occupancy (User Address: StatusOcc)</b>		
<b>OCCUPIED</b>	Controller is in Occupied mode	Any of the following: Network input (SchedOcc) containing a time-of-day schedule flag from either the Excel 10 Zone Manager or an E-Bus Controller; Time Clock DI, Occupancy Sensor DI; or from Network input (ManMode) for manual override to OCC mode. ManMode has the highest priority, followed by the Time Clock DI, and then SchedOcc.
<b>STANDBY</b>	Controller is in Standby mode	Either: (A) Network input (SchedOcc) containing a time-of-day schedule flag from the Excel 10 Zone Manager or other E-Bus node is STANDBY, or (B) Network input (SchedOcc) is OCCUPIED and the Occupancy Sensor DI is UNOCCUPIED.
<b>UNOCCUPIED</b>	Controller is in Unoccupied mode	Network input (SchedOcc) containing a time-of-day schedule flag from the Excel 10 Zone Manager or E-Bus, or the network input DestManualOcc has a value of UNOCCUPIED.

(continued)

**Table 5. Modes Of Operation For The Excel 10 W7750 Controller (continued).**

Mode	Description	Events causing a controller to switch to this mode
<b>BYPASS OCCUPIED</b>	Controller is in Occupied mode through a Bypass command	This mode is derived from the schedule occupancy (SchedOcc) having a state of UNOCCUPIED and a manual request for occupancy from one of three sources. Two of these are signals originated external to the unit, and received by DestManualOcc and DestBypass. The third source for an occupancy request is from an override button located on a wall module. These three sources are arbitrated in a scheme determined by the configuration parameter (Network Wins or Last-in Wins from OvrPriority).
<b>Override Modes (User Address: StatusOvr)</b>		
<b>OCCUPIED</b>	Controller occupancy mode was overridden to Occupied mode	Network input (DestManualOcc) containing a time-of-day schedule override signal of OCCUPIED from the Excel 10 Zone Manager or other E-Bus device.
<b>STANDBY</b>	Controller occupancy mode was overridden to Standby mode	Network input (DestManualOcc) containing a time-of-day schedule override signal of STANDBY from the Excel 10 Zone Manager or other E-Bus device.
<b>UNOCCUPIED</b>	Controller occupancy mode was overridden to Unoccupied mode	Network input (DestManualOcc) containing a time-of-day schedule override signal of UNOCCUPIED from the Excel 10 Zone Manager or other E-Bus device.
<b>BYPASS</b>	Controller occupancy mode was overridden to Bypass the current Unoccupied mode	DI (Bypass) was pressed, and the Bypass duration timer has not yet expired, or the network input DestManualOcc has a value of BYPASS.
<b>NOT ASSIGNED</b>	No Bypass action	No Override input received.
<b>Operational Modes (User Address: StatusMode)</b>		
<b>START-UP AND WAIT</b>	On power-up, provides a staggered start sequence to evenly apply the load to the electrical system.	This mode occurs on controller power-up, and after downloading to the controller from the configuration tool. Temperature control loops are disabled.
<b>COOLING</b>	The Excel 10 is controlling the Cooling mode.	Space temperature has risen above the current cooling setpoint, or the network input (DestHvacMode) is COOL.
<b>HEATING</b>	The Excel 10 is controlling the Heating mode.	Space temperature has fallen below the current heating setpoint, or the network input (DestHvacMode) is HEAT.
<b>EMERGENCY HEAT</b>	Compressors are disabled and only Auxiliary Heat stages are allowed to operate.	The network input (DestManHvacMode) is EMERG_HEAT.
<b>OFF MODE</b>	The heat/cool control is turned off immediately. The node is not running its normal temperature control.	Network input (DestManMode) containing AHU operational mode information from C-Bus has value of MORNING WARM-UP.
<b>DISABLED MODE</b>	The heat/cool control and frost protection are turned off immediately. The node is not running its normal temperature control.	—
<b>SMOKE EMERGENCY</b>	The node has entered a smoke emergency. The fan and dampers are then set to the conditions configured by SmkCtlMode. The control remains in SMOKE_EMERGENCY until power is cycled or the node receives DestEmergCmd set to EMERG_NORMAL.	Network input (DestEmergCmd) containing smoke control signal from another E-Bus device has value of SMOKE_EMERG.
<b>FREEZE PROTECT</b>	The temperature control is set to HEAT with the setpoint set to the frost limit setpoint 46.4°F (8°C).	The Window digital input detects an open window.

(continued)

**Table 5. Modes Of Operation For The Excel 10 W7750 Controller (continued).**

<b>MANUAL POSITION</b>	The physical outputs are being controlled manually. The temperature control loop is turned off.	Typically this is done by the user through E-Vision or XBS by setting the point DestManMode to MANUAL mode.
<b>FAN ONLY</b>	Control algorithm is disabled, except that the fan is turned on.	The space temperature sensor has failed, or the network input (DestHvacMode) is FAN ONLY.
<b>DISABLED</b>	Control algorithm is shut off.	Network input (ManMode) containing AHU operational mode information from C-Bus has value of DISABLED.

NOTE: During all modes all digital and analog physical inputs are periodically read, the diagnostic output network variables can be polled, the input network variables are received, and the output network variables are sent periodically.

## APPLICATION STEPS

### Overview

The seven application steps shown in Table 6 are planning considerations for engineering an Excel 10 W7750 System. These steps are guidelines intended to aid understanding of the product I/O options, bus arrangement choices, configuration options and the Excel 10 W7750 Controller role in the overall EXCEL 5000® OPEN™ SYSTEM architecture.

**Table 6. Application Steps.**

Step No.	Description
1	Plan The System
2	Determine Other Bus Devices Required
3	Lay Out Communication and Power Wiring
4	Prepare Wiring Diagrams
5	Order Equipment
6	Configure Controllers
7	Troubleshooting

### Step 1. Plan the System

Plan the use of the W7750 Controllers according to the job requirements. Determine the location, functionality and sensor or actuator usage. Verify the sales estimate of the number of W7750 Controllers and T7770 Wall Modules and T7780A DDWMs required for each model type. Also check the number and type of output actuators and other required accessories.

When planning the system layout, consider potential expansion possibilities to allow for future growth. Planning is very important to be prepared for adding HVAC systems and controllers in future projects.

The T7770 Wall Modules can be installed as either hardwired I/O-only devices or additional wiring can be run to them (for the E-Bus network ) to allow a CARE/E-Vision operator terminal to have access to the E-Bus. The application engineer needs to determine how many wall modules, T7770s and T7780s are required. T7780s are

connected to the E-Bus and occupy a node address. All T7780A DDWMs and T7770 Wall Modules, except the T7770A1006 and the T7770A1014, can be connected via the E-Bus network access jack. Also the application engineer needs to know how many T7770s without E-Bus network connections are being installed on the job, and then clearly document which wall modules (if any) have network access. This information is required during installation to ensure that the proper number and type of wires are pulled to the wall modules, and the building operators are informed about where they can plug in to the E-Bus network with a portable operator terminal (see Fig. 17 and 18). Refer to Step 4. Prepare Wiring Diagrams for details, about the about the wiring differences between the two types.

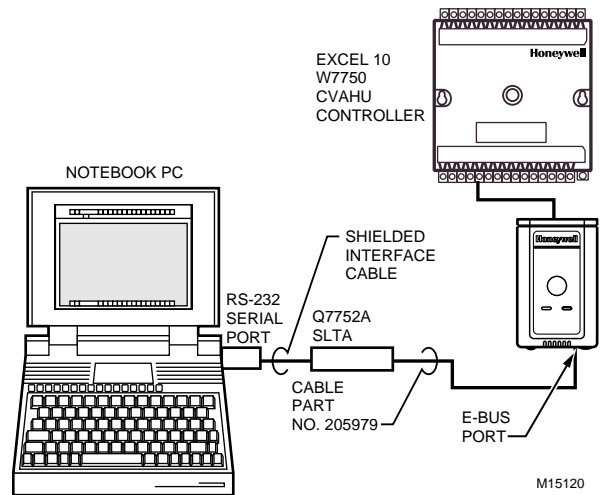

**Fig. 17. Connecting the portable operator terminal to the E-Bus.**

The FTT communication wiring, (E-Bus) between controllers is a free topology scheme that supports star, loop, and/or bus wiring. Refer to the E-Bus Wiring Guidelines form, 74-2865 for complete description of network topology rules. See Application Step 3. Lay Out Communications and Power Wiring, for more information on bus wiring layout, and see Fig. 25 through 32 in Application Step 4. Prepare Wiring Diagrams, for wiring details.

The application engineer must review the Direct Digital Control (DDC) job requirements. This includes the Sequences of Operation for the W7750 units, and for the system as a whole. Usually there are variables that must be passed between the W7750 Controllers and other zone controller(s), or central plant controller(s) that are required for optimum system-wide operation. Typical examples are the

TOD Occ/Unocc signal, the outdoor air temperature, the demand limit control signal, and the smoke control mode signal.

It is important to understand these interrelationships early in the job engineering process to ensure implementing when configuring the controllers. (See Application Step 6. Configure Controllers, for information on the various Excel 10 parameters and on Excel 10 point mapping.)

## Step 2. Determine Other Bus Devices Required

A maximum of 62 nodes can communicate on a single E-Bus segment. Each W7750 (CVAHU) Controller or T7780A DDWM constitutes one node. If more nodes are required, a Q7751A,B Router is necessary. Using a router allows up to

125 nodes, divided between two E-Bus segments. The router accounts for two of these nodes (one node on each side of the router); a Q7750A Excel 10 Zone Manager takes one node and two nodes are available for operator terminal nodes, leaving 120 nodes available for Excel 10 Controllers and T7780A DDWMs. All 120 controllers and T7780A DDWMs are able to talk to each other through the router. A Q7750A Excel 10 Zone Manager is required to connect the E-Bus to the standard EXCEL 5000® System C-Bus. Each Excel 10 Zone Manager can support no more than 120 Excel 10 Controllers and T7780A DDWMs. This limit is set in the Excel 10 Zone Manager database as an absolute maximum.

Each E-Bus segment is set up with two unused nodes to allow for a CARE/E-Vision operator terminal to be connected to the E-Bus. Multiple CARE/E-Vision terminals can be connected to the E-Bus at the same time. Table 7 summarizes the E-Bus segment configuration rules.

**Table 7. E-Bus Configuration Rules And Device Node Numbers.**

<b>One E-Bus Segment Example</b>	<b>Maximum Number of Nodes Equals 62</b>
One Q7750A Excel 10 Zone Manager	1 node
Port for operator terminal access (CARE/E-Vision)	1 node
Maximum number of Excel 10s and T7780A DDWMs	60 nodes (T7780A DDWMs are E-Bus nodes)
<b>Total</b>	<b>62 nodes</b>
<b>Two E-Bus Segments Example</b>	<b>Maximum Number of Nodes Equals 125</b>
One Q7750A Excel 10 Zone Manager	1 node
One Q7751A,B Router	2 nodes (1 in each Bus Segment)
Ports for operator terminal access (two CARE/E-Vision terminals)	2 nodes (1 in each Bus Segment)
Maximum number of Excel 10s and T7780A DDWMs in segment number one	60 nodes (T7780A DDWMs are E-Bus nodes)
Maximum number of Excel 10s and T7780A DDWMs in segment number two	60 nodes (T7780A DDWMs are E-Bus nodes)
<b>Total</b>	<b>125 nodes</b>

Refer to the E-Bus Wiring Guidelines form, 74-2865 for complete description of network topology rules and the maximum wire length limitations. If longer runs are required, a Q7740A 2-Way or Q7740B 4-Way Repeater can be added to extend the length of the E-Bus. A Q7751A,B Router can be added to partition the system into two segments and effectively double the length of the E-Bus. Only one router is allowed with each Excel 10 Zone Manager, and each network segment can have a maximum of one repeater.

In addition, all E-Bus segments require the installation of a 209541B Termination Module for a singly terminated E-Bus or two 209541B Termination Modules for a doubly terminated E-Bus. For more details on E-Bus termination, refer to the E-Bus Wiring Guidelines form, 74-2865, or see Application Step 3. Lay Out Communications and Power Wiring, and the E-Bus Termination Module subsection in Application Step 4.

## Step 3. Lay Out Communications and Power Wiring

### E-Bus Layout

The communications bus, E-Bus, is a 78-kilobit serial link that uses transformer isolation and differential Manchester encoding. Approved cable types for E-Bus communications wiring is Level IV 22 AWG (0.34 mm<sup>2</sup>) plenum or non-plenum rated unshielded, twisted pair, solid conductor wire. For nonplenum areas, use Level IV 22 AWG (0.325 mm<sup>2</sup>), such as US part AK3781 (one pair) or US part AK3782 (two pair). In plenum areas, use plenum-rated Level IV, 22 AWG (0.325 mm<sup>2</sup>) such as US part AK3791 (one pair) or US part AK3792 (two pair). See Tables 9 and 11 for part numbers. Contact Echelon® Corp. Technical Support for the recommended vendors of Echelon® approved cables. The FTT communications bus, E-Bus, supports a polarity insensitive, free topology wiring scheme that supports star, loop, and/or bus wiring.

E-Bus networks can be configured in a variety of ways, so refer to the E-Bus Wiring Guidelines form, 74-2865 for complete description of network topology rules and Table 7. Fig. 18 and 19 depict two typical E-Bus network topologies; One has only one doubly terminated E-Bus segment that has 60 nodes or less, and one showing two singly terminated E-Bus segments that has 120 nodes or less (60 MAX per each segment). The bus configuration is set up using the Network Manager tool from within CARE (see the CARE Excel 10 Zone Manager User's Guide, form 74-1392).

NOTE: For wiring details see the E-Bus Termination Module subsection in Step 4. For wall module wiring, US part AK3782 (non-plenum) or US part AK3792 (plenum) can be used. For an E-Bus that is a doubly terminated daisy-chain, these cables contain two twisted pairs (one for the run down to the wall module, and one for the run back up to the controller) for ease of installation.

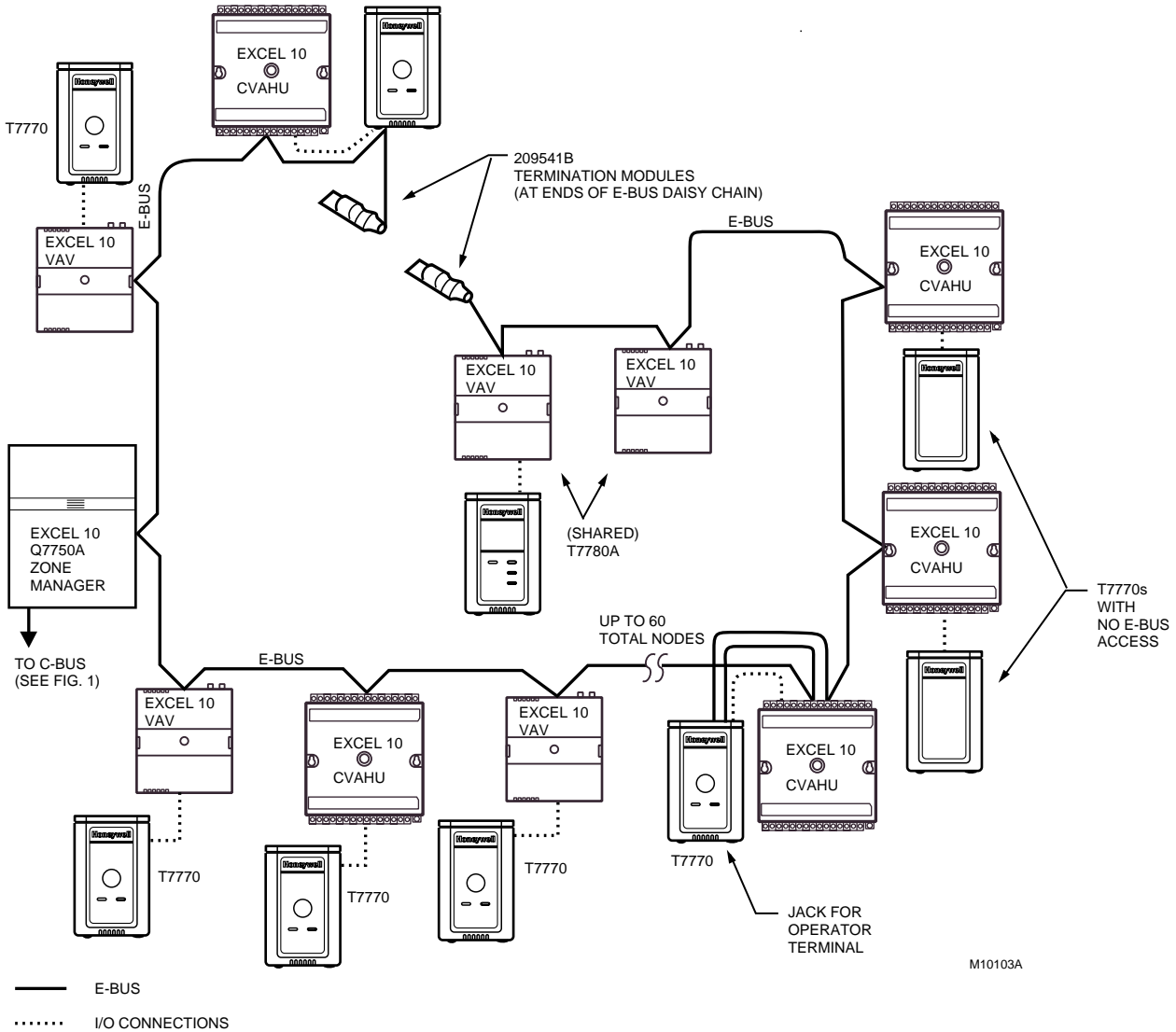

Fig. 18. Wiring layout for one doubly terminated daisy-chain E-Bus segment.

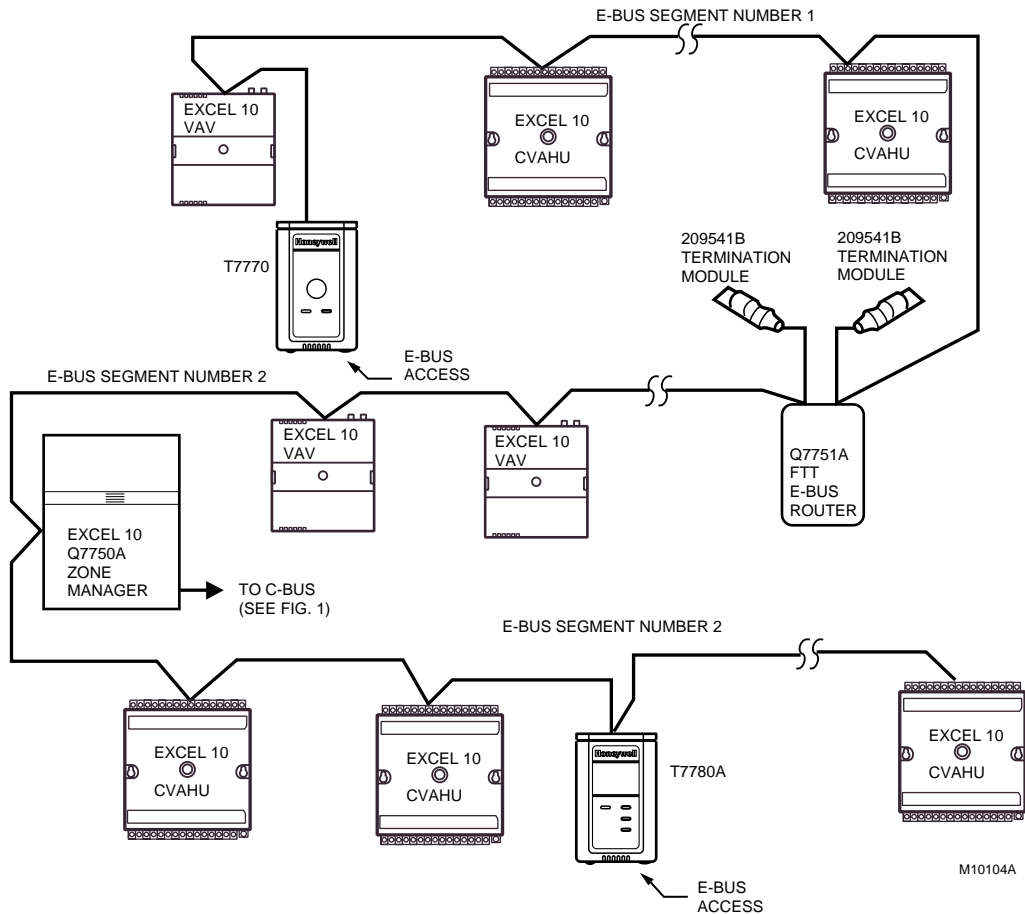

Fig. 19. Wiring layout for two singly terminated E-Bus segments.

NOTE: See the E-Bus Termination Module section for wiring details.

**IMPORTANT**

Notes on communications wiring:

- All field wiring must conform to local codes and ordinances or as specified on installation wiring diagrams.
- Approved cable types for E-Bus communications wiring is Level IV 22 AWG (0.34 mm<sup>2</sup>) plenum or non-plenum rated unshielded, twisted pair, solid conductor wire. For nonplenum areas, use Level IV 22 AWG (0.34 mm<sup>2</sup>), such as US part AK3781 (one pair) or US part AK3782 (two pair). In plenum areas, use plenum-rated Level IV, 22 AWG (0.34 mm<sup>2</sup>) such as US part AK3791 (one pair) or US part AK3792 (two pair). See Tables 9 and 11 for part numbers. Contact Echelon® Corp. Technical Support for the recommended vendors of Echelon® approved cables.
- Unswitched 24 Vac power wiring can be run in the same conduit as the E-Bus cable.
- Do not use different wire types or gauges on the same E-Bus segment. The step change in line impedance characteristics causes unpredictable reflections on the bus. When using different types is unavoidable, use a Q7751A,B Router at the junction.

- In noisy (high EMI) environments, avoid wire runs parallel to noisy power cables, or lines containing lighting dimmer switches, and keep at least 3 in. (76 mm) of separation between noisy lines and the E-Bus cable.
- Make sure that neither of the E-Bus wires is grounded.

**Power Wiring**

A power budget must be calculated for each Excel 10 W7750 Controller to determine the required transformer size for proper operation. A power budget is simply the summing of the maximum power draw ratings (in VA) of all the devices to be controlled by an Excel 10 W7750 Controller. This includes the controller itself, the equipment actuators (ML6161, or other motors) and various contactors and transducers, as appropriate, for the Excel 10 configuration.

**Power Budget Calculation Example**

The following is an example power budget calculation for a typical W7750B Excel 10 W7750 Controller.

Assume a W7750 unit with a fan, two stages of D/X cooling, modulating steam valve for heating, and modulating economizer dampers. The power requirements are:

Device	VA	Information Obtained from
Excel 10 W7750 Controller	6.0	W7750 Specification Data
ML6161 Damper Actuator	2.2	TRADELIN® Catalog
R8242A Contactor for fan	21.0	TRADELIN® Catalog in-rush rating
D/X Stages	0.0	
NOTE: For this example, assume the cooling stage outputs are wired into a compressor control circuit and, therefore, have no impact on the power budget.)		
M6410A Steam Heating Coil Valve	0.7	TRADELIN® Catalog, 0.32A at 24 Vac
TOTAL: 29.9 VA		

The Excel 10 System example requires 29.9 VA of peak power; therefore, a 40 VA AT72D Transformer is able to provide ample power for this controller and its accessories. Alternatively, a 75 VA AT88A Transformer could be used to power two Excel 10 Systems of this type, or a 100 VA AT92A Transformer could be used to power three of these controllers and meet NEC Class 2 restrictions (no greater than 100 VA). See Fig. 21 and 22 for illustrations of power wiring details. See Table 8 for VA ratings of various devices.

**Table 8. VA Ratings For Transformer Sizing.**

Device	Description	VA
W7750A,B	Excel 10 W7750 Controller	6.0
T7780A	DDWM	0.8
ML6161A/B	Damper Actuator, 35 lb-in.	2.2
R8242A	Contactor	21.0
M6410A	Valve Actuator	0.7
MMC325	Pneumatic Transducer	5.0
ML684	Versadrive Valve Actuator	12.0
ML6464	Damper Actuator, 66 lb-in.	3.0
ML6474	Damper Actuator, 132 lb-in.	3.0
ML6185	Damper Actuator SR 50 lb-in.	12.0
ML7984B	PWM Valve Actuator	6.0

For contactors and similar devices, the in-rush power ratings should be used as the worst case values when performing power budget calculations. Also, the application engineer must consider the possible combinations of simultaneously energized outputs and calculate the VA ratings accordingly. The worst case, that uses the largest possible VA load, should be determined when sizing the transformer.

**Line Loss**

Excel 10 Controllers must receive a minimum supply voltage of 20 Vac. If long power or output wire runs are required, a voltage drop due to Ohms Law (I x R) line loss must be considered. This line loss can result in a significant increase in total power required and thereby affect transformer sizing. The following example is an I x R line-loss calculation for a 200 ft (61m) run from the transformer to a W7750 Controller drawing 37 VA using two 18 AWG (1.0 mm<sup>2</sup>) wires.

The formula is:

$$\text{Loss} = [\text{length of round-trip wire run (ft)}] \times [\text{resistance in wire (ohms per ft)}] \times [\text{current in wire (amperes)}]$$

From specification data:

18 AWG twisted pair wire has 6.38 ohms per 1000 feet.

$$\text{Loss} = [(400 \text{ ft}) \times (6.38/1000 \text{ ohms per ft})] \times [(37 \text{ VA})/(24\text{V})] = 4.0 \text{ volts}$$

This means that four volts are going to be lost between the transformer and the controller; therefore, to assure the controller receives at least 20 volts, the transformer must output more than 24 volts. Because all transformer output voltage levels depend on the size of the connected load, a larger transformer outputs a higher voltage than a smaller one for a given load. Fig. 20 shows this voltage load dependence.

In the preceding I x R loss example, even though the controller load is only 37 VA, a standard 40 VA transformer is not sufficient due to the line loss. From Fig. 20, a 40 VA transformer is just under 100 percent loaded (for the 37 VA controller) and, therefore, has a secondary voltage of 22.9 volts. (Use the lower edge of the shaded zone in Fig. 20 that represents the worst case conditions.) When the I x R loss of four volts is subtracted, only 18.9 volts reaches the controller, which is not enough voltage for proper operation.

In this situation, the engineer basically has three alternatives:

1. Use a larger transformer; for example, if an 80 VA model is used, see Fig. 20, an output of 24.4 volts minus the four volt line loss supplies 20.4V to the controller. Although acceptable, the four-volt line-loss in this example is higher than recommended. See the following **IMPORTANT**.
2. Use heavier gauge wire for the power run. 14 AWG (2.0 mm<sup>2</sup>) wire has a resistance of 2.57 ohms per 1000 ft which, using the preceding formula, gives a line-loss of only 1.58 volts (compared with 4.02 volts). This would allow a 40 VA transformer to be used. 14 AWG (2.0 mm<sup>2</sup>) wire is the recommended wire size for 24 Vac wiring.
3. Locate the transformer closer to the controller, thereby reducing the length of the wire run, and the line loss.

The issue of line-loss is also important in the case of the output wiring connected to the Triac digital outputs. The same formula and method are used. The rule to remember is to keep all power and output wire runs as short as practical. When necessary, use heavier gauge wire, a bigger transformer, or install the transformer closer to the controller.

**IMPORTANT**

*No installation should be designed where the line loss is greater than two volts to allow for nominal operation if the primary voltage drops to 102 Vac (120 Vac minus 15 percent).*

To meet the National Electrical Manufacturers Association (NEMA) standards, a transformer must stay within the NEMA limits. The chart in Fig. 20 shows the required limits at various loads.

With 100 percent load, the transformer secondary must supply between 23 and 25 volts to meet the NEMA standard. When a purchased transformer meets the NEMA standard DC20-1986, the transformer voltage-regulating ability can be considered reliable. Compliance with the NEMA standard is voluntary.

The following Honeywell transformers meet this NEMA standard:

Transformer Type	VA Rating
AT20A	20
AT40A	40
AT72D	40
AT87A	50
AK3310 Assembly	100

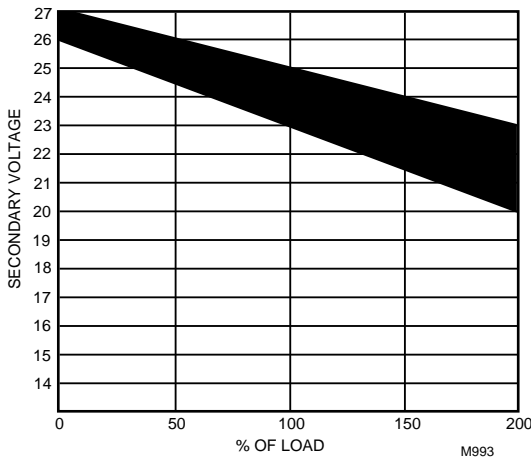

Fig. 20. NEMA class 2 transformer voltage output limits.

Attach earth ground to W7750 Controller terminal 1. See Fig. 21, 22 and 23, 25 through 32.

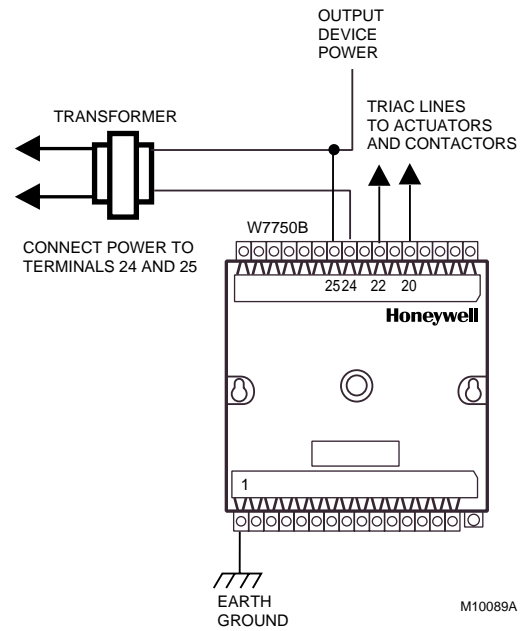

Fig. 21. Power wiring details for one Excel 10 per transformer.

See Fig. 22. for wiring more than one Excel 10 per transformer.

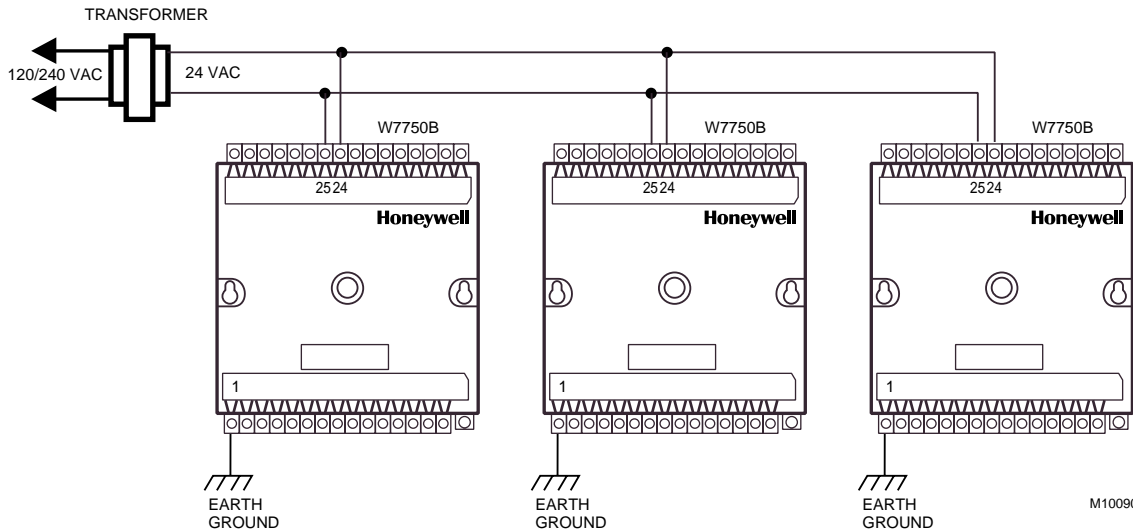
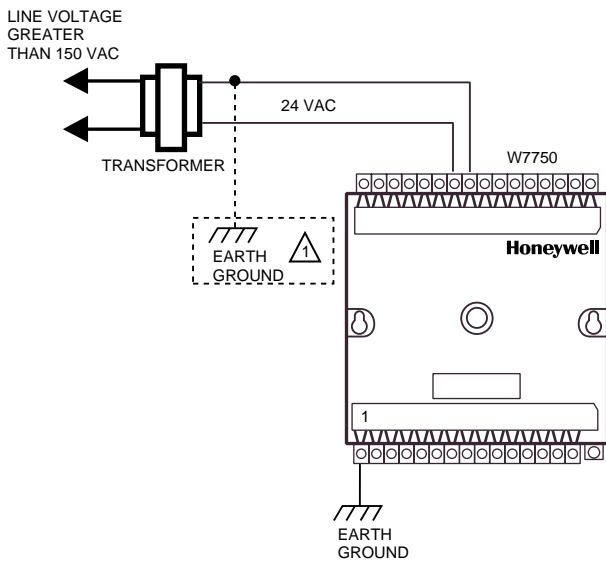

Fig. 22. Power wiring details for two or more Excel 10s per transformer.

**IMPORTANT**

If the W7750 Controller is used on **Heating and Cooling Equipment (UL 1995 US only)** devices and the transformer primary power is more than 150 volts, connect the transformer secondary to earth ground, see Fig. 23.



**⚠** IF THE W7750 CONTROLLER IS USED IN UL 1995 EQUIPMENT AND THE PRIMARY POWER IS MORE THAN 150 VOLTS, GROUND ONE SIDE OF TRANSFORMER SECONDARY.

M10088

Fig. 23. Transformer power wiring details for one Excel 10 used in UL 1995 equipment (US only).

**IMPORTANT**

Notes on power wiring:

- All field wiring must conform to local codes and ordinances or as specified on installation wiring diagrams.

- To maintain NEC Class 2 and UL ratings, the installation must use transformers of 100 VA or less capacity.
- For multiple controllers operating from a single transformer, the same side of the transformer secondary must be connected to the same input terminal in each controller (21 on the W7750A and 24 on the W7750B) and the ground terminals must be connected to a verified earth ground for each controller in the group. See Fig. 22. (Controller configurations are not necessarily limited to three devices per transformer.)
- For the W7750B Controller (which has Triac outputs), all output devices must be powered from the same transformer as the one powering the Excel 10 W7750 Controller.
- Use the heaviest gauge wire available, up to 14 AWG (2.0 mm<sup>2</sup>) with a minimum of 18 AWG (1.0 mm<sup>2</sup>) for all power and earth ground connections.
- To minimize EMI noise, do not run Triac output wires in the same conduit as the input wires or the E-Bus communications wiring.
- Unswitched 24 Vac power wiring can be run in the same conduit as the E-Bus cable.
- Make earth ground connections with the shortest possible wire run using 14 AWG (2.0 mm<sup>2</sup>) wire. A good earth ground is essential for W7750 operation. Ideally, connect the earth ground to the ground bus at a motor control center or circuit breaker panel. However, if the nearest ideal earth ground is inaccessible, consider an alternate source for earth ground. Metal water pipe is generally a good ground, but do not use sprinkler pipe if prohibited by local codes. Attention must be given when duct work, conduit, or rebar are to be considered as ground sources. It is the responsibility of the installer to assure that these structures are tied back to a known earth ground.

## Step 4. Prepare Wiring Diagrams

### General Considerations

The purpose of this step is to assist the application engineer in developing job drawings to meet job specifications. Wiring details are included for the W7750A,B and the T7770 and T7780A DDWM. The drawings detail I/O, power, and E-Bus communication wiring connections.

NOTE: For field wiring, when two or more wires, other than 14 AWG (2.0 mm<sup>2</sup>) are to be attached to the same connector block terminal, be sure to twist them together. Deviation from this rule can result in improper electrical contact. See Fig. 24.

The connector block terminals on the W7750 and on the T7770 and T7780A DDWM accept 14 through 22 AWG (2.0 to 0.34 mm<sup>2</sup>) wire. Table 9 lists wiring types, sizes, and length restrictions for Excel 10 products.

Table 9. Field Wiring Reference Table.

Wire Function	Recommended Minimum Wire Size AWG (mm <sup>2</sup> )	Construction	Specification or Requirement	Vendor Wire Type	Maximum Length ft (m)
<b>E-Bus (Plenum)</b>	22 AWG (0.34 mm <sup>2</sup> )	Twisted pair solid conductor, nonshielded or Echelon® approved cable.	Level IV 140°F (60°C) rating	Honeywell AK3791 (one twisted pair) AK3792 (two twisted pairs)	Refer to E-Bus Wiring Guidelines for maximum length
<b>E-Bus (Non-Plenum)</b>	22 AWG (0.34 mm <sup>2</sup> )	Twisted pair solid conductor, nonshielded or Echelon® approved cable.	Level IV 140°F (60°C) rating	Honeywell AK3781 (one twisted pair) AK3782 (two twisted pairs)	Refer to E-Bus Wiring Guidelines for maximum length
<b>Input Wiring Sensors Contacts</b>	18 to 22 AWG (1.0 to 0.34 mm <sup>2</sup> )	Multiconductor (usually five-wire cable bundle). For runs >200 ft (61m) in noisy EMI areas, use shielded cable.	140°F (60°C) rating	Standard thermostat wire	1000 ft (305m) for 18 AWG 200 ft (61m) for 22 AWG
<b>Output Wiring Actuators Relays</b>	14 AWG (2.0 mm <sup>2</sup> ) (18 AWG (1.0 mm <sup>2</sup> ) acceptable for short runs)	Any pair nonshielded (use heavier wire for longer runs).	NEC Class 2 140°F (60°C) rating	Honeywell AK3702 (18 AWG) AK3712 (16 AWG) AK3754 (14 AWG) or equivalent	Limited by line-loss effects on power consumption. (See Line Loss subsection.)
<b>Power Wiring</b>	14 AWG (2.0 mm <sup>2</sup> )	Any pair nonshielded (use heavier wire for longer runs).	NEC Class 2 140°F (60°C) rating	Honeywell AK3754 (14 AWG) twisted pair AK3909 (14 AWG) single conductor or equivalent	Limited by line-loss effects on power consumption. (See Line Loss subsection.)

### W7750 Controllers

Fig. 25 through 32 illustrate W7750A,B Controller wiring for various configurations. Connections to the wall module terminals (2 through 6) and the communications terminals (14 and 15) are made at terminal blocks. Connection for access to the E-Bus is provided by plugging the connector into the communications jack.

NOTE: If an Excel 10 W7750A,B Controller or Zone Manager is not connected to a good earth ground, the controller internal transient protection circuitry is compromised and the function of protecting the controller from noise and power line spikes cannot be fulfilled. This can result in a damaged circuit board and require replacing the controller.

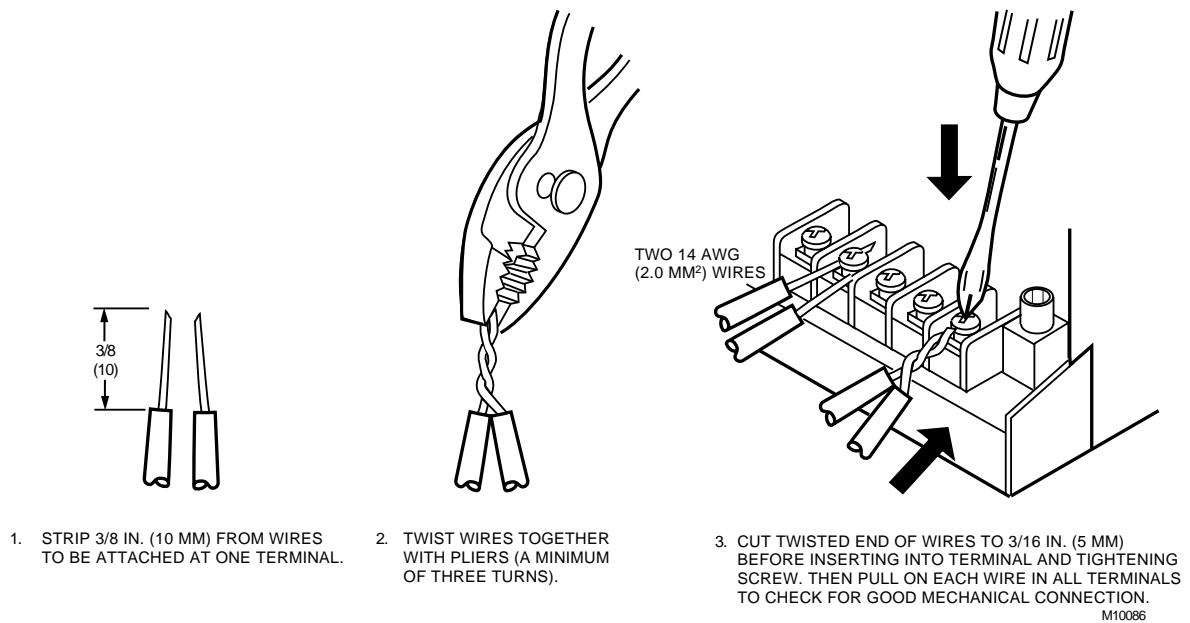

Fig. 24. Attaching two or more wires at terminal blocks.

See Table 10 for a description of the W7750A terminals.

Table 10. W7750A Version I/O Description.

Terminal	Terminal Number	Description
DO6—(W1)	31	Heat 1 (or Reversing Valve for a Heat Pump)
DO5—(W2)	30	Heat 2 (or Aux. Heat for a Heat Pump)
DO4—(Y1)	29	Cool 1 (or Compressor 1 for a Heat Pump)
DO3—(Y2)	28	Cool 2 (or Compressor 2 for a Heat Pump)
DO2—(G)	27	Fan
DO1—NET	26	Network Digital Output
DO1—NET	25	Network Digital Output (connect to terminal number 22 +24Vac)
Rc	24	Control power for relay contacts DO2 (G), DO3 (Y1) and DO4 (Y2)
Rh	23	Control power for relay contacts DO5 (W1) and DO6 (W2)
+24Vac (H)	22	Power for the controller
COM (N)	21	Return for power to controller
E-Bus	14 and 15	Echelon® communications (E-Bus) screw terminals
DI - 2	12	Digital Input 2
DGND	11	Digital Ground
DGND	10	Digital Ground
DI - 1	9	Digital Input 1
AGND	8	Analog ground
AI - 1 OHM	7	Analog Input 1 (used for Discharge Air Temperature Sensor)
SET PT	6	Space temperature setpoint pot
GROUND	5	Wall Module
SENSOR	4	Space temperature sensor
BYPASS	3	Space override button
LED	2	Space LED for indication of manual occupancy status
EARTH GND	1	Earth Ground

**IMPORTANT**

If the W7750A controller is configured by E-Vision, the outputs may be assigned in different order than the defaults. Use the Custom Wiring function of E-Vision to re-assign the outputs to the desired terminals.

The W7750B Version is preconfigured with the same default setup as the W7750A Model; however, some terminals for wiring connections differ on the W7750B Model. See in Fig. 28 for the terminal names on the W7750B Model. The default configuration of the digital output points on the W7750B Model follows:

**Digital Outputs:**

- FREE 1 (OUT 1) DO1—NETWORK DO
- (OUT 2) DO2—SUPPLY FAN START/STOP
- (OUT 3) DO3—COOL\_STAGE\_2
- (OUT 4) DO4—COOL\_STAGE\_1
- (OUT 5) DO5—HEAT\_STAGE\_2
- (OUT 6) DO6—HEAT\_STAGE\_1
- DO7—UNUSED
- DO8—UNUSED

The Wall Module terminals are identical for the W7750A and W7750B Models.

The W7750B Model offers two voltage/current sensor input terminals. When current-type sensors (4 to 20 mA) are configured, the W7750B automatically switches a 249 ohm resistor into the sensing circuit; so no external resistor is required. The W7750A Model does not support voltage or current inputs.

**NOTE:** If using factory defaults, DI-2 input is configured for ScheduleMaster (nvolO.SchedMaster). For a stand-alone unit either connect an external time clock to terminals 9 and 10 or put a jumper on terminals 9 and 10 (using a jumper puts the controller in continuous occupied mode).

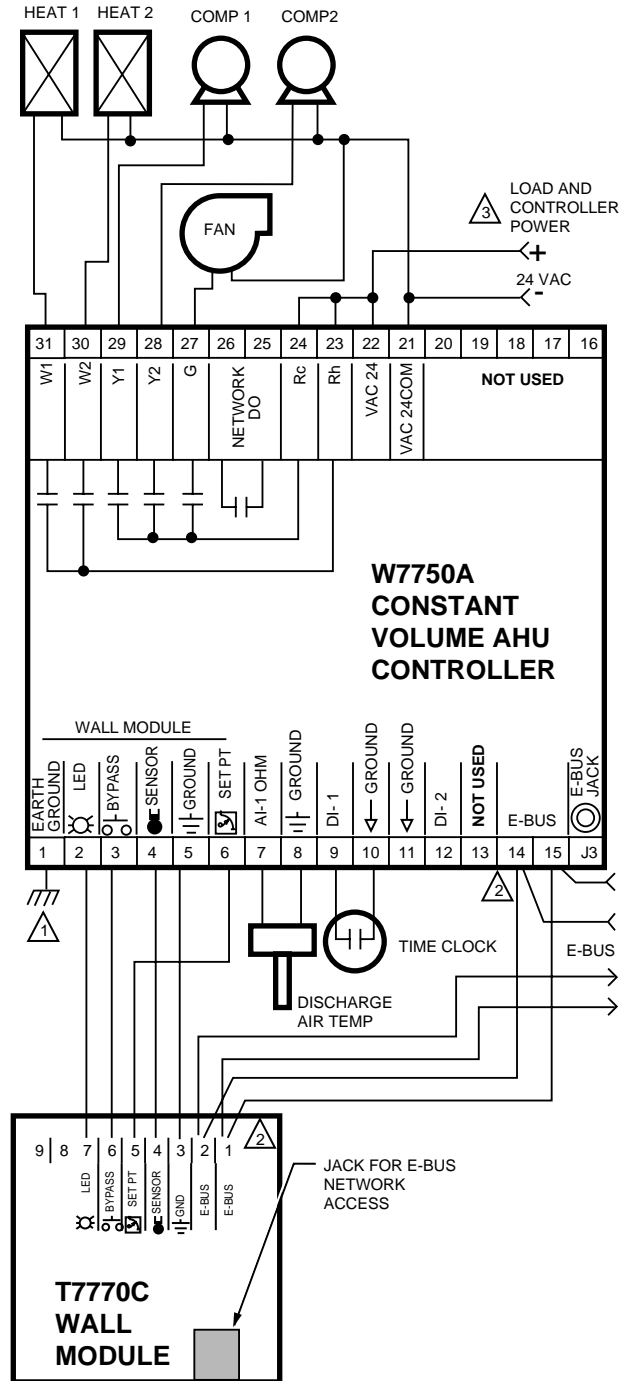

- 1 EARTH GROUND WIRE LENGTH SHOULD BE HELD TO A MINIMUM. USE THE HEAVIEST GAUGE WIRE AVAILABLE, UP TO 14 AWG (2.0 MM<sup>2</sup>) WITH A MINIMUM OF 18 AWG (1.0 MM<sup>2</sup>), FOR EARTH GROUND WIRE.
- 2 TO ASSURE PROPER ELECTRICAL CONTACT, WIRES MUST BE TWISTED TOGETHER BEFORE INSERTION INTO THE TERMINAL BLOCK.
- 3 LOAD POWER WIRE CAN BE CONNECTED TO TERMINAL 22.

M10085B

**Fig. 25. Typical W7750A Controller AHU application wiring diagram. (For more information on note 2, refer to Fig. 24.)**

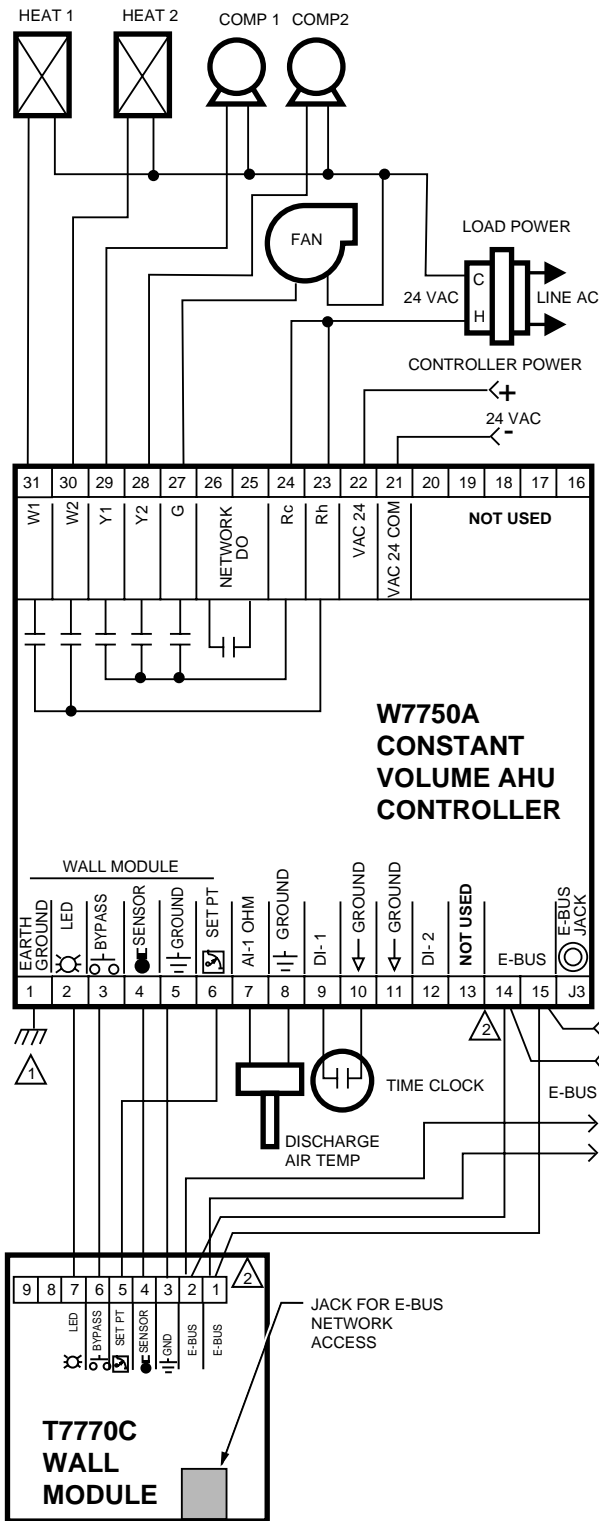

- 1 EARTH GROUND WIRE LENGTH SHOULD BE HELD TO A MINIMUM. USE THE HEAVIEST GAUGE WIRE AVAILABLE, UP TO 14 AWG (2.0 MM<sup>2</sup>) WITH A MINIMUM OF 18 AWG (1.0 MM<sup>2</sup>), FOR EARTH GROUND WIRE.
- 2 TO ASSURE PROPER ELECTRICAL CONTACT, WIRES MUST BE TWISTED TOGETHER BEFORE INSERTION INTO THE TERMINAL BLOCK.

**Fig. 26. Typical W7750A Controller with separate transformer application wiring diagram.**  
(For more information on note 2, refer to Fig. 24.)

M10084B

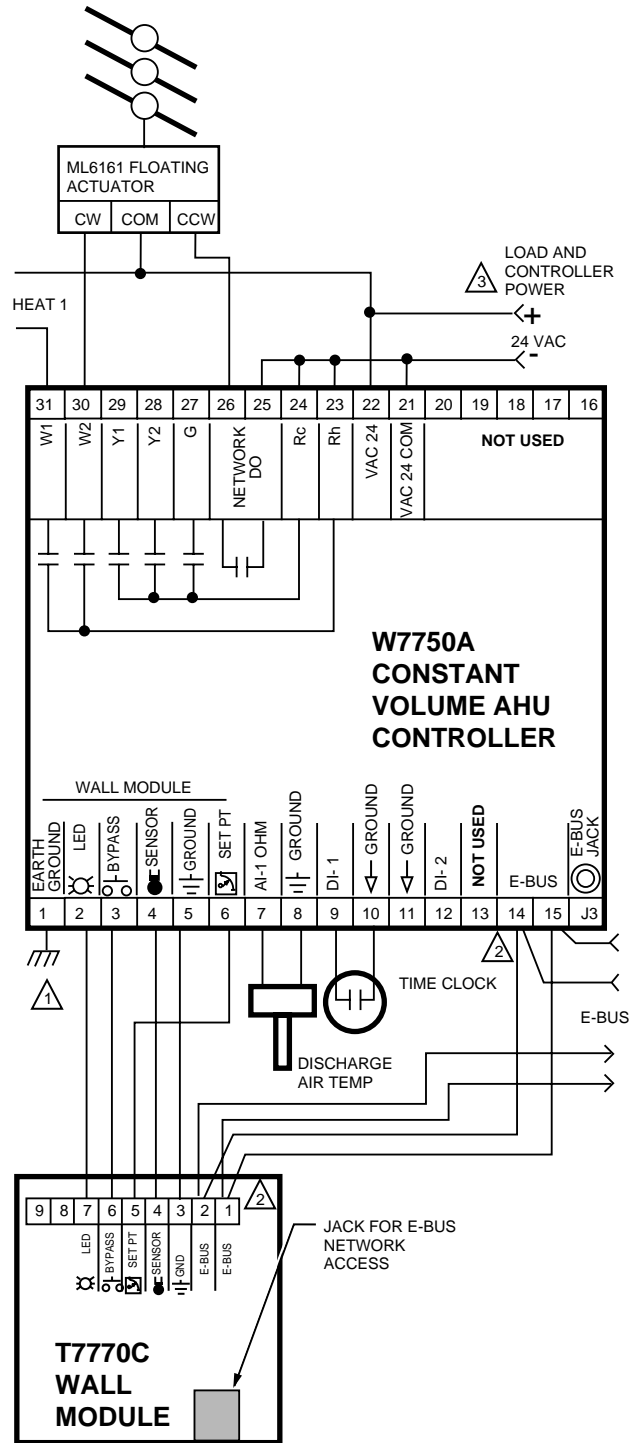

- 1 EARTH GROUND WIRE LENGTH SHOULD BE HELD TO A MINIMUM. USE THE HEAVIEST GAUGE WIRE AVAILABLE, UP TO 14 AWG (2.0 MM<sup>2</sup>) WITH A MINIMUM OF 18 AWG (1.0 MM<sup>2</sup>), FOR EARTH GROUND WIRE.
- 2 TO ASSURE PROPER ELECTRICAL CONTACT, WIRES MUST BE TWISTED TOGETHER BEFORE INSERTION INTO THE TERMINAL BLOCK.
- 3 LOAD POWER WIRE CAN BE CONNECTED TO TERMINAL 22.

**Fig. 27. W7750A Controller floating economizer damper wiring diagram.** (For more information on note 2, refer to Fig. 24.)

M10083B

NOTE: Digital outputs are configurable. The terminal locations for each function are user-selectable.

The Network DO is configured to be economizer float close in this figure and W2 is configured to be economizer float open. Physical output terminal features are done in E-Vision by the custom wiring function.

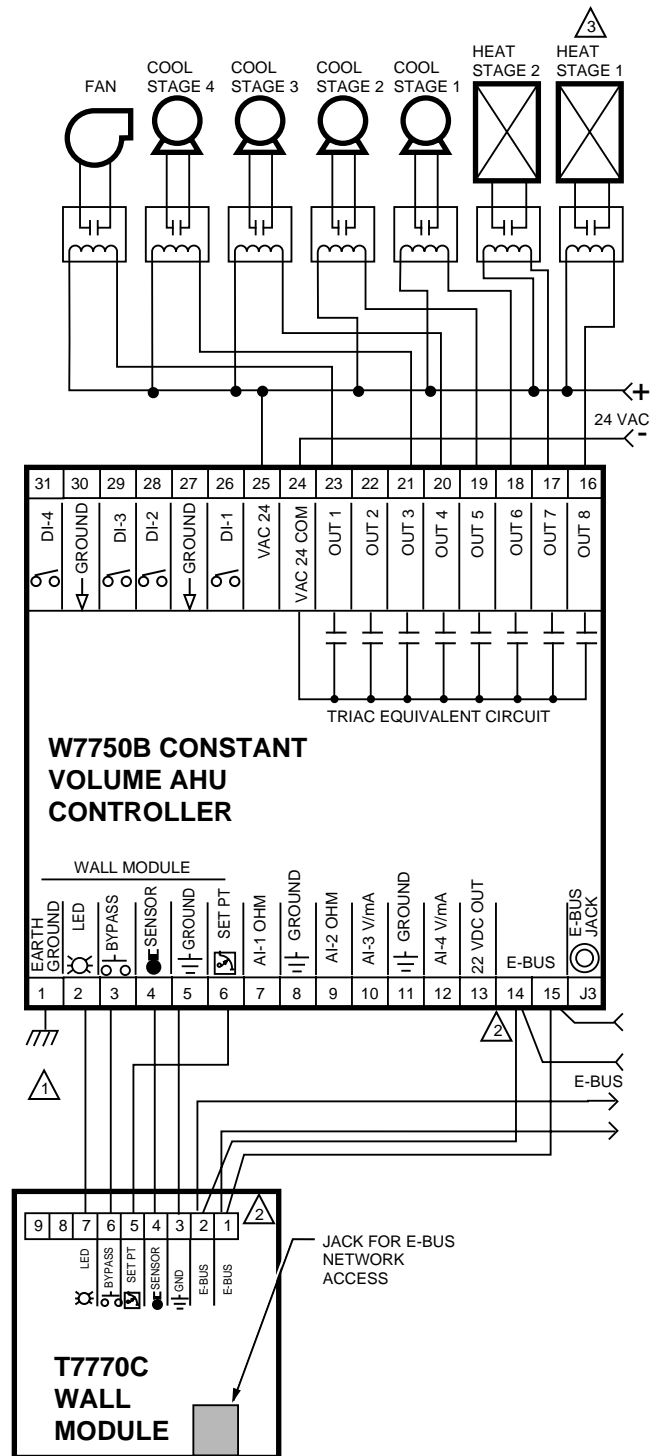

- 1 EARTH GROUND WIRE LENGTH SHOULD BE HELD TO A MINIMUM. USE THE HEAVIEST GAUGE WIRE AVAILABLE, UP TO 14 AWG (2.0 MM<sup>2</sup>) WITH A MINIMUM OF 18 AWG (1.0 MM<sup>2</sup>), FOR EARTH GROUND WIRE.
- 2 TO ASSURE PROPER ELECTRICAL CONTACT, WIRES MUST BE TWISTED TOGETHER BEFORE INSERTION INTO THE TERMINAL BLOCK.
- 3 IF THE HEAT EQUIPMENT IS GAS-FIRED, CONFIGURE THE IGNITER AS HEAT STAGE 1, AND PHYSICALLY CONNECT IT TO OUT 8. THIS OUTPUT HAS BUILT-IN ELECTRICAL NOISE SUPPRESSION TO HANDLE IGNITOR CIRCUITS, WHICH ARE TYPICALLY VERY NOISY.

M10082A

Fig. 28. Typical W7750B Controller with staged heating and cooling wiring diagram. (For more information on note 2, refer to Fig. 24.)

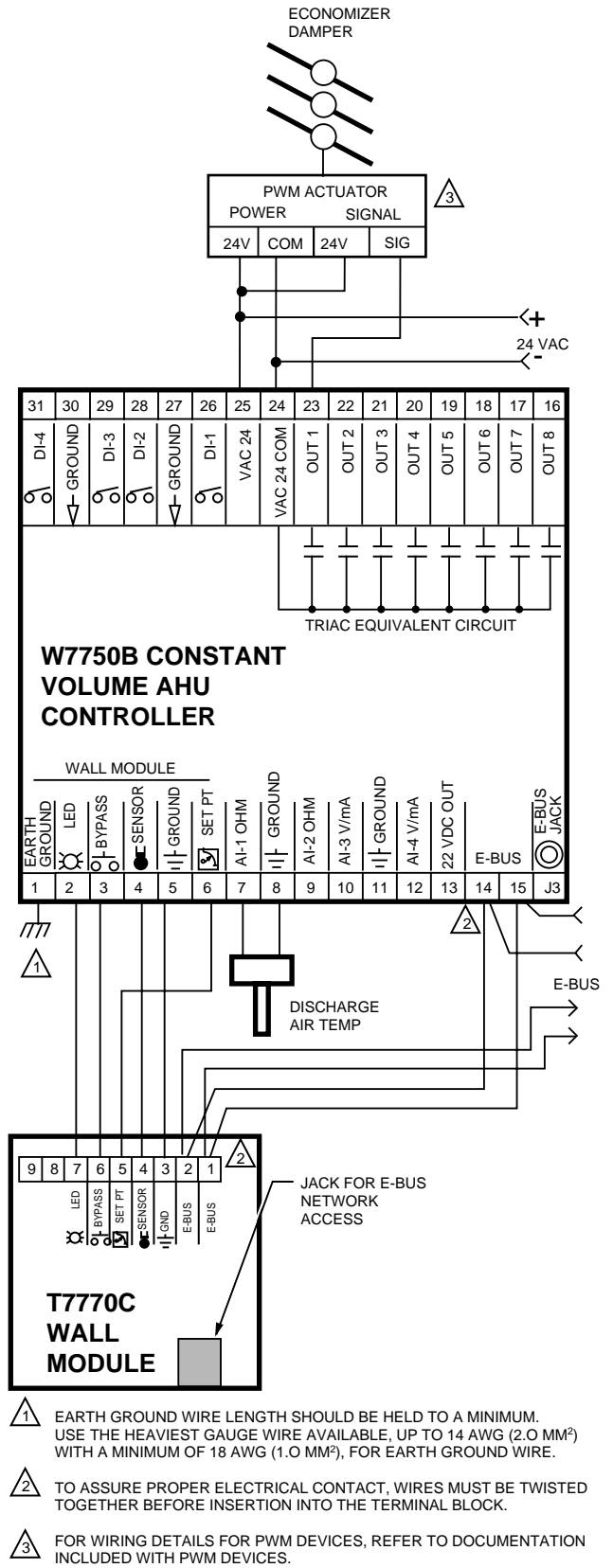
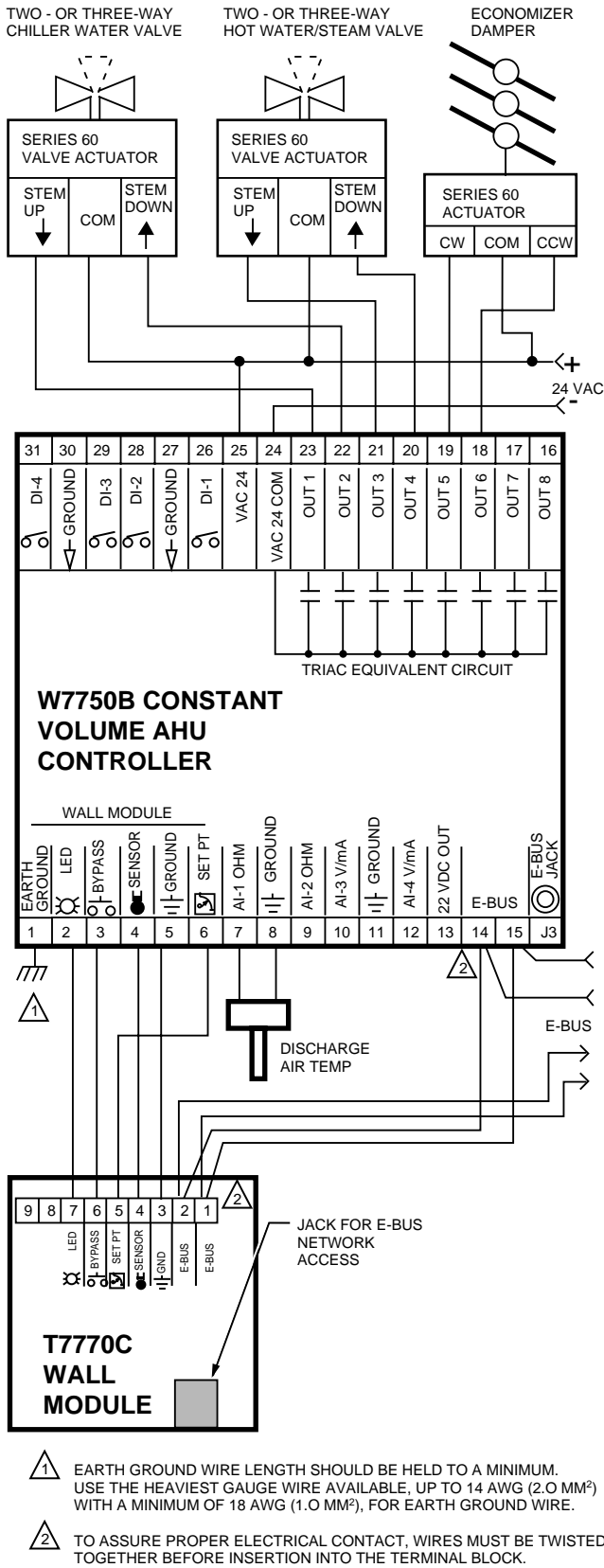

- 1 EARTH GROUND WIRE LENGTH SHOULD BE HELD TO A MINIMUM. USE THE HEAVIEST GAUGE WIRE AVAILABLE, UP TO 14 AWG (2.0 MM<sup>2</sup>) WITH A MINIMUM OF 18 AWG (1.0 MM<sup>2</sup>), FOR EARTH GROUND WIRE.
- 2 TO ASSURE PROPER ELECTRICAL CONTACT, WIRES MUST BE TWISTED TOGETHER BEFORE INSERTION INTO THE TERMINAL BLOCK.
- 3 FOR WIRING DETAILS FOR PWM DEVICES, REFER TO DOCUMENTATION INCLUDED WITH PWM DEVICES.

M10081A

M10080A

Fig. 29. W7750B Controller with floating heating, cooling and economizer wiring diagram. (For more information on note 2, refer to Fig. 24.)

Fig. 30. W7750B Controller PWM damper actuator wiring diagram. (For more information on note 2, refer to Fig. 24.)

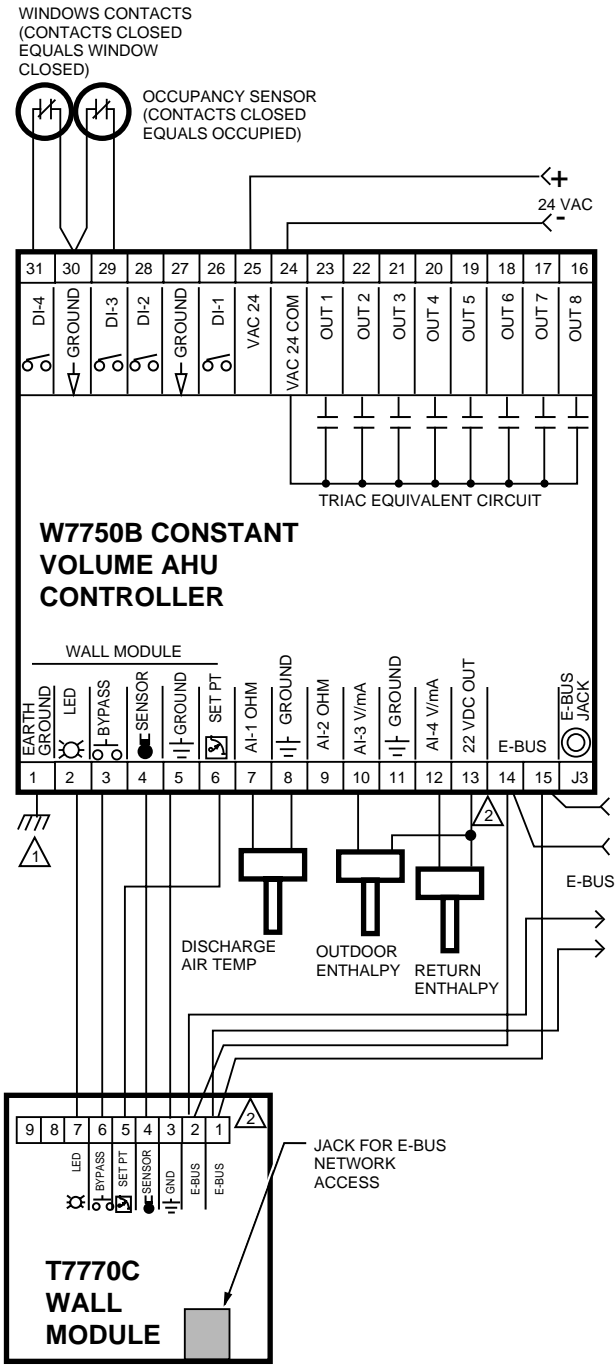

- 1 EARTH GROUND WIRE LENGTH SHOULD BE HELD TO A MINIMUM. USE THE HEAVIEST GAUGE WIRE AVAILABLE, UP TO 14 AWG (2.0 MM<sup>2</sup>) WITH A MINIMUM OF 18 AWG (1.0 MM<sup>2</sup>), FOR EARTH GROUND WIRE.
- 2 TO ASSURE PROPER ELECTRICAL CONTACT, WIRES MUST BE TWISTED TOGETHER BEFORE INSERTION INTO THE TERMINAL BLOCK.

M10079A

Fig. 31. W7750B Controller with C7400A 4 to 20 mA enthalpy sensor wiring diagram. (For more information on note 2, refer to Fig. 24.)

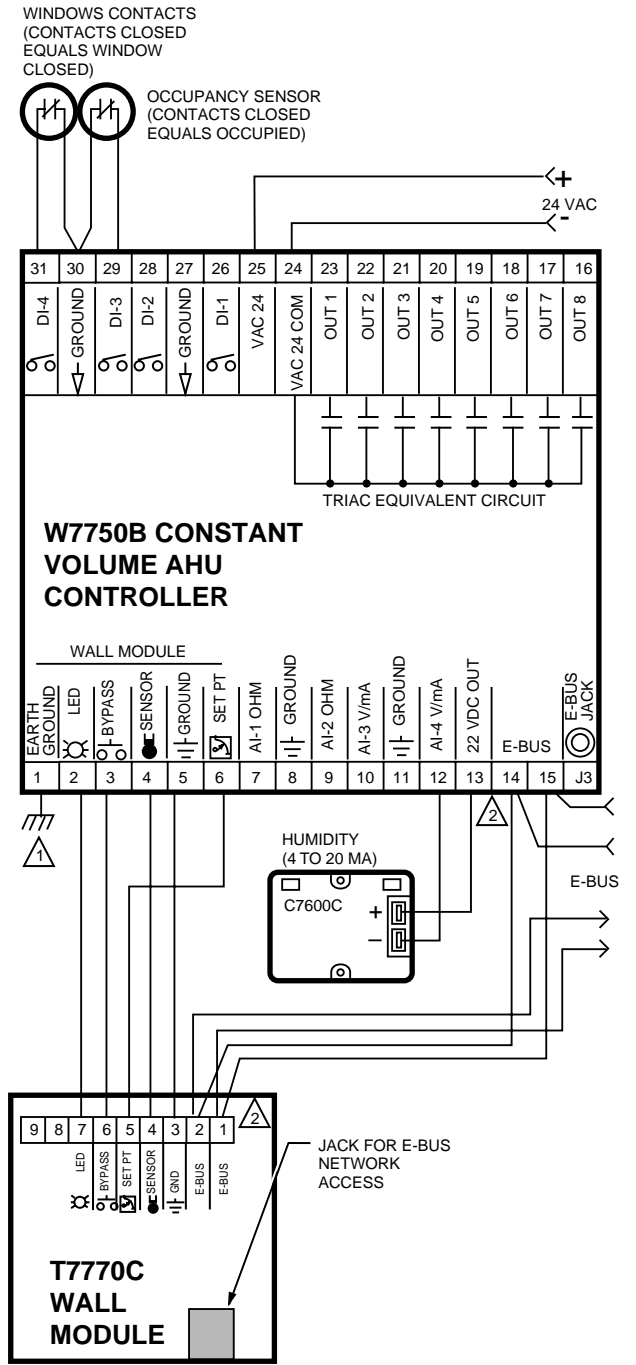

- 1 EARTH GROUND WIRE LENGTH SHOULD BE HELD TO A MINIMUM. USE THE HEAVIEST GAUGE WIRE AVAILABLE, UP TO 14 AWG (2.0 MM<sup>2</sup>) WITH A MINIMUM OF 18 AWG (1.0 MM<sup>2</sup>), FOR EARTH GROUND WIRE.
- 2 TO ASSURE PROPER ELECTRICAL CONTACT, WIRES MUST BE TWISTED TOGETHER BEFORE INSERTION INTO THE TERMINAL BLOCK.

M11619

Fig. 32. W7750B Controller with C7600C 4 to 20 mA solid state humidity sensor wiring diagram. (For more information on note 2, refer to Fig. 24.)

See Fig. 33 to wire a pneumatic transducer to a W7750B.

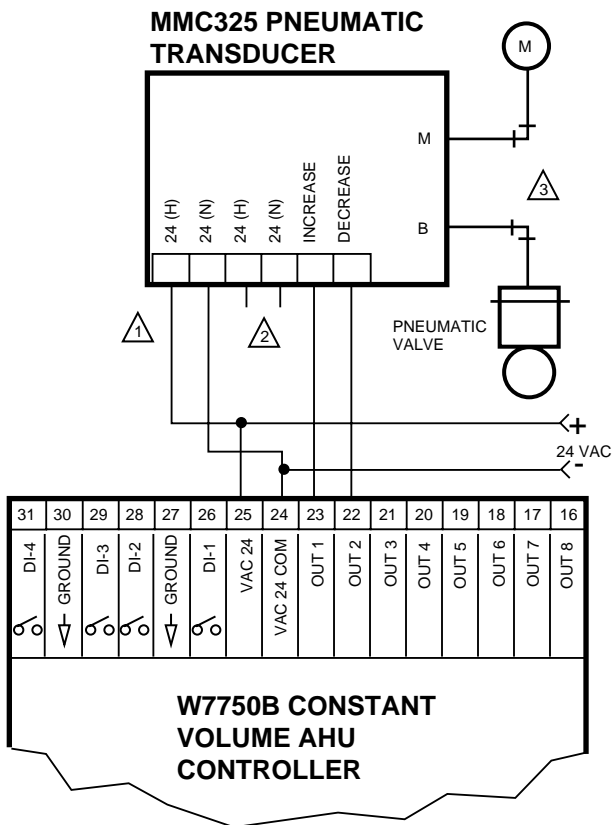

- ⚠ MAKE SURE ALL TRANSFORMER/POWER WIRING IS AS SHOWN; REVERSING TERMINATIONS RESULTS IN EQUIPMENT MALFUNCTION.
- ⚡ OPTIONAL 24 VAC WIRING TO NEXT CONTROLLER.
- ⚠ USE 1/4 IN (6 MM) PNEUMATIC TUBING. MINIMUM BRANCH LINE MUST BE 6 FT. (1.8M) OR LONGER.

M10078B

Fig. 33. Pneumatic transducer to W7750B.

### E-Bus Termination Module

One 209541B Excel 10 FTT Termination Module is required for a singly terminated E-Bus segment. Two 209541B Excel 10 FTT Termination Modules are required for a doubly terminated daisy-chain E-Bus segment (see Fig. 34). Refer to E-Bus Wiring Guidelines form, 74-2865 for termination module placement rules.

For 209541B Excel 10 FTT Termination module placement and wiring options, see Fig. 35.

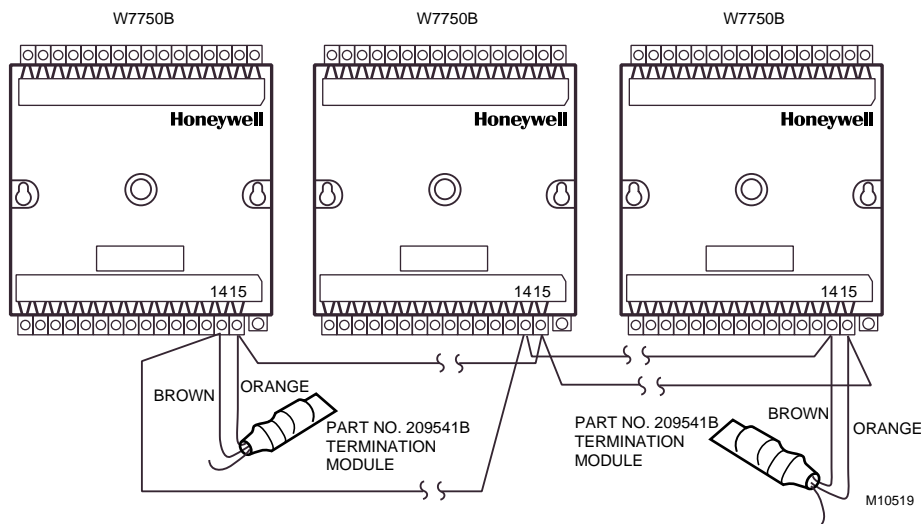
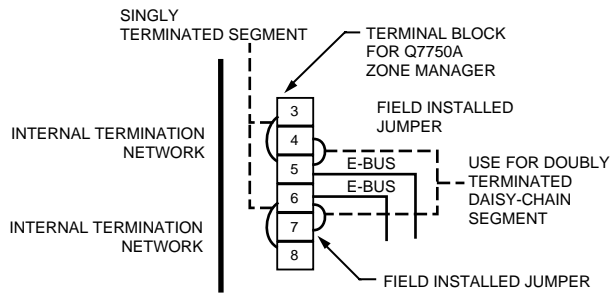
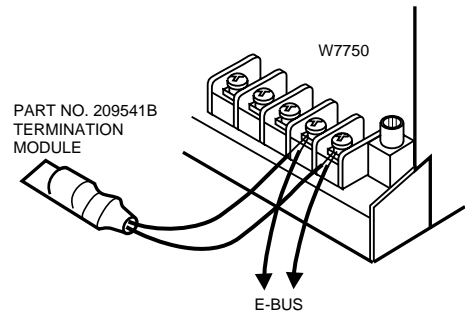

Fig. 34. Typical doubly terminated daisy-chain E-Bus segment termination module wiring diagram.



(A) Enabling Internal Termination Network using jumpers in the Q7750A Zone Manager



(B) Installing E-Bus Termination Module at W7750

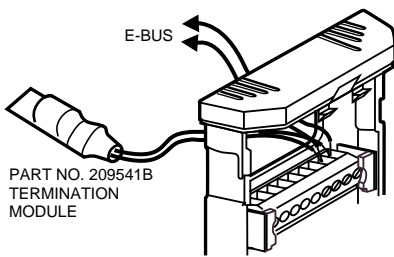

INSERT INTO TERMINALS 1 AND 2 WITH THE E-BUS WIRE. TERMINATION MODULE IS PHYSICALLY LOCATED BEHIND THE T7750 INSIDE THE 2 X 4 OR 60 MM BOX.

(C) E-Bus Termination Module installed at 2 x 4 or 60 mm box-mounted T7750

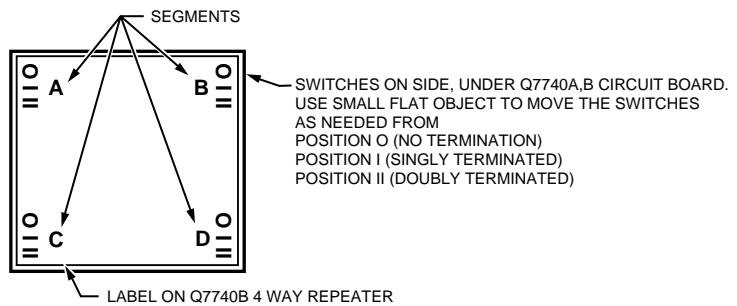

NOTE: Q7740B 4 WAY REPEATER SHOWN, Q7740A 2 WAY REPEATER HAS TWO SWITCHES.

(D) E-Bus Termination network switches in the Q7740A, B Repeaters

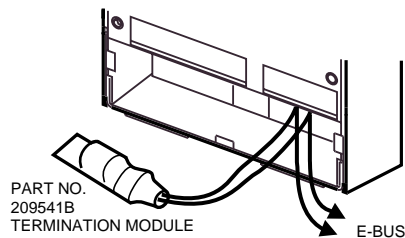

(E) Installing E-Bus Termination Module at W7751H (terminals 11 and 12)

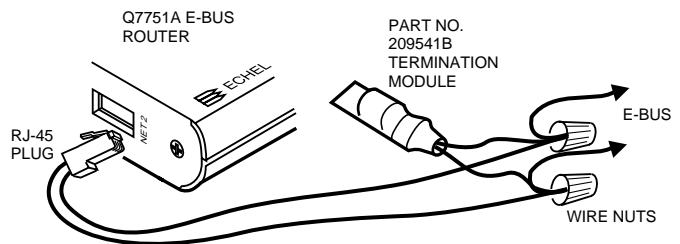

(F) Twist wires and attach wire nuts to RJ-45 Adapter cables, E-Bus segment wires and Termination Module to connect to a Q7751A,B Router

M11618

Fig. 35. E-Bus termination wiring options.

## Step 5. Order Equipment

After compiling a bill of materials through completion of the previous application steps, refer to Table 11 for ordering information. Contact Honeywell for information about Controllers and Wall Modules with no logo.

**Table 11. Excel 10 W7750 Controller Ordering Information.**

Part Number	Product Description	Comments
<b>Excel 10 W7750 Controllers:</b>		
W7750A2005	Constant Volume AHU Controller (W7750A)	Three Analog Inputs, Three Digital Inputs and Six 24 Vac Relay Outputs
W7750B2003	Constant Volume AHU Controller (W7750B)	Six Analog Inputs, Five Digital Inputs and Eight Triac Outputs
<b>T7770 Wall Modules:</b>		
T7770A1006	Sensor with Honeywell Logo	Used with Excel 5000 and Excel 10 Controllers
T7770A1014	Sensor with No Logo	Used with Excel 5000 and Excel 10 Controllers
T7770A2004	Sensor with Network Jack and Honeywell Logo	Used with Excel 5000 and Excel 10 Controllers
T7770A2012	Sensor with Network Jack and No Logo	Used with Excel 5000 and Excel 10 Controllers
T7770B1004	Sensor with Setpoint and Network Jack, Honeywell Logo	Degrees F Absolute
T7770B1046	Sensor with Setpoint and Network Jack, Honeywell Logo	Relative Setpoint
T7770B1012	Sensor with Setpoint and Network Jack, No Logo	Degrees F Absolute
T7770B1020	Sensor with Setpoint and Network Jack, Honeywell Logo	Degrees C Absolute
T7770B1053	Sensor with Setpoint and Network Jack, No Logo	Relative Setpoint
T7770B1038	Sensor with Setpoint and Network Jack, No Logo	Degrees C Absolute
T7770C1002	Sensor with Setpoint, Bypass/LED and Network Jack, Honeywell Logo	Degrees F Absolute
T7770C1044	Sensor with Setpoint, Bypass/LED and Network Jack, Honeywell Logo	Relative Setpoint
T7770C1010	Sensor with Setpoint, Bypass/LED and Network Jack, No Logo	Degrees F Absolute
T7770C1028	Sensor with Setpoint, Bypass/LED and Network Jack, Honeywell Logo	Degrees C Absolute
T7770C1051	Sensor with Setpoint, Bypass/LED and Network Jack, No Logo	Relative Setpoint
T7770C1036	Sensor with Setpoint, Bypass/LED and Network Jack, No Logo	Degrees C Absolute
T7770D1000	Sensor with Bypass/LED and Network Jack, Honeywell Logo	Degrees F Absolute
T7770D1018	Sensor with Bypass/LED and Network Jack, No Logo	Degrees C Absolute
T7780A1004	Sensor, Digital Display Wall Module with Network Jack, Honeywell Logo	Degrees F Absolute (default)
T7780A1012	Sensor, Digital Display Wall Module with Network Jack, No Logo	Degrees F Absolute (default)
<b>Sensors</b>		
C7770A1006	Air Temperature Sensor. 20 Kohm NTC nonlinearized	Duct-mounted sensor that functions as a primary and/or secondary sensor.
C7031J1050	Averaging Discharge/Return Air Temperature Sensor. 20 Kohm NTC	Duct element cord length 12 ft. (3.7m)
C7031B1033	Discharge Air or Hot Water Temperature Sensor. 20 Kohm NTC	Use 112622AA Immersion Well
C7031C1031	Duct Discharge/Return Air Sensor. 20 Kohm	18 in. (457mm) insertion length.

(continued)

**Table 11. Excel 10 W7750 Controller Ordering Information (continued).**

Part Number	Product Description	Comments
C7031D1062	Hot or chilled Water Temperature Sensor. 20 Kohm NTC	—
C7031F1018	Outside Air Temperature Sensor. 20 Kohm NTC	—
C7031K1017	Hot or chilled Water Temperature Sensor. 20 Kohm NTC	Strap-on
C7100A1015	Averaging Discharge/Return Air Temperature Sensor. PT3000	13 in. (330mm) insertion length.
C7170A1002	Outdoor Air Temperature Sensor. PT3000	—
<b>Echelon® Based Components and Parts:</b>		
Q7750A2003	Excel 10 Zone Manager	Free Topology Transceiver (FTT)
Q7751A2002	Router	(FTT)
Q7751B2000	Router	Twisted Pair Transceiver (78 kbs) to FTT
Q7752A2001	Serial Interface	(FTT)
Q7752A2009	Serial Interface (PCMCIA card)	(FTT)
Q7740A1008	Excel 10 2-Way Repeater	Used to extend the length of the E-Bus. Contains built in termination modules.
Q7740B1006	Excel 10 4-Way Repeater	Used to extend the length of the E-Bus. Contains built in termination modules.
XD 505A	Standard C-Bus Communications Submodule	—
XD 508	C-Bus Communications Submodule (1 megabit baud rate)	—
209541B	Termination Module	One or two required per E-Bus segment
205979	Operator Terminal Cable for E-Bus	Serial interface to wall module or controller
<b>Accessories:</b>		
EL7680A1008	Wall Mounted Wide View Infrared Occupancy Sensor	—
EL7628A1007	Ceiling Mounted Infrared Occupancy Sensor	—
EL7611A1003, EL7612A1001	Ultrasonic Occupancy Sensors	—
EL7630A1003, EL7621A1002, EL7621A1010	Power Supply/Control Units for Occupancy sensors	—
C7400A1004	Solid State Enthalpy Sensor (4 to 20 mA)	For outdoor and return air enthalpy
C7600B1000	Solid State Humidity Sensor (2 to 10 V)	For outdoor and return air humidity
C7600C1008	Solid State Humidity Sensor (4 to 20 mA)	For outdoor and return air humidity
C7600C1018	Solid State Humidity Sensor (2 to 10 V)	For outdoor and return air humidity
<b>Accessories:</b>		
MMC325-010, MMC325-020	Pneumatic Retrofit Transducers. Select pressure range: (010) 0 to 10 psi (68.97 kPa) or (020) 0 to 20 psi (137.93 kPa).	Use to control Pneumatic reheat valves
MMCA530	DIN rail adapter for MMC325 Transducers	—
MMCA540	Metal enclosure for MMC325 Transducers	—
ML7984B3000	Valve Actuator Pulse Width Modulation (PWM)	Use with V5011 or V5013 F and G Valves
ML6161B1000	Damper Actuator Series 60	—
M6410A	Valve Actuator Series 60	Use with V5812/V5813 Valves
ML684A1025	Versadrive Valve Actuator with linkage, Series 60	Use with V5011 and V5013 Valves

(continued)

Table 11. Excel 10 W7750 Controller Ordering Information (continued).

Part Number	Product Description	Comments
ML6464A1009	Direct Coupled Actuator, 66 lb-in. torque, Series 60	—
ML6474A1008	Direct Coupled Actuator, 132 lb-in. torque, Series 60	—
ML6185A1000	Direct Coupled Actuator, 50 lb-in. spring return	Series 60
V5812A	Two-way terminal unit water valve; 0.19, 0.29, 0.47, 0.74, 1.2, and 1.9 C <sub>V</sub> 1/2 in. npt (13 mm) or 2.9 and 4.9 C <sub>V</sub> 3/4 in. npt (19 mm)	Use with M6410 Valve Actuator. Closeoff rating for 0.19 to 1.9 C <sub>V</sub> is 65 psi; for 2.9 and 4.9, C <sub>V</sub> is 45 psi. (Coefficient of volume or capacity index C <sub>V</sub> = gallons per minute divided by the square root of the pressure drop across the valve.)
V5813A	Three-way mixing terminal unit hot water valve; 0.19, 0.29, 0.47, 0.74, 1.2, and 1.9 C <sub>V</sub> 1/2 in. npt (13 mm) or 2.9 and 4.9 C <sub>V</sub> 3/4 in. npt (19 mm)	Use with M6410 Valve Actuator. Closeoff rating for 0.19 to 0.74 C <sub>V</sub> is 55 psi; 1.2, and 1.9 C <sub>V</sub> is 22 psi; 2.9 and 4.9 C <sub>V</sub> is 26 psi.
R8242A	Contactor, 24 Vac coil, DPDT	—
AT72D, AT88A, AK3310, etc.	Transformers	—
EN 50 022	DIN rail 35 mm by 7.5 mm (1-3/8 in. by 5/16 in.)	Obtain locally: Each controller requires 5 in.
—	Augat Inc. part number 2TK2D DIN rail (adapter)	Purchase from Augat Inc. two DIN rail adapters for each controller
<b>Cabling:</b>		
—	Serial Interface Cable, male DB-9 to female DB-9 or female DB-25.	Obtain locally from any computer hardware vendor.
Honeywell AK3791 (one twisted pair) AK3792 (two twisted pairs)	E-Bus (plenum): 22 AWG (0.34 mm <sup>2</sup> ) twisted pair solid conductor, nonshielded or Echelon® approved cable.	Level IV 140°F (60°C) rating
Honeywell AK3781 (one twisted pair) AK3782 (two twisted pairs)	E-Bus (nonplenum): 22 AWG (0.34 mm <sup>2</sup> ) twisted pair solid conductor, nonshielded or Echelon® approved cable.	Level IV 140°F (60°C) rating
Honeywell AK3725	Inputs: 18 AWG (1.0 mm <sup>2</sup> ) five wire cable bundle	Standard thermostat wire
Honeywell AK3752 (typical or equivalent)	Outputs/Power: 14 to 18 AWG (2.0 to 1.0 mm <sup>2</sup> )	NEC Class 2 140°F (60°C) rating
Honeywell AK3702 (typical or equivalent)	18 AWG (1.0 mm <sup>2</sup> ) twisted pair	Non-plenum
Honeywell AK3712 (typical or equivalent)	16 AWG (1.3 mm <sup>2</sup> ) twisted pair	Non-plenum
Honeywell AK3754 (typical or equivalent)	14 AWG (2.0 mm <sup>2</sup> ) two conductor	Non-plenum

## Step 6. Configure Controllers

Excel E-Vision PC Software is used to configure W7750 Controllers to match their intended application. The E-Vision User Guide, form number 74-2588 provides details for operating the PC software.

W7750 Controllers are shipped from the factory with a default hardware configuration. On power-up, the controller configuration parameters are set to the default values listed in Table C-1 in Appendix C. The controller can operate normally in this mode (if the equipment and wiring match the default setup), and given valid sensor inputs, the outputs are controlled appropriately to maintain space temperature at the default setpoint. The default I/O arrangement for the W7750A is printed on the terminal labels. Also see the wiring details in Fig. 25 in Step 4, Prepare Wiring Diagrams. The labeled I/O terminals are defined in Table 10.

## Step 7. Troubleshooting

### Troubleshooting Excel 10 Controllers and Wall Modules

In addition to the following information, refer to the Installation Instructions and Checkout and Test manual for each product. Most products have a Checkout and Test section in their Installation Instructions manual. If not, look for a separate Checkout and Test manual. See the Applicable Literature section for form numbers.

### Temperature Sensor and Setpoint Potentiometer Resistance Ranges

The T7770 or T7780A DDWM or the C7770A Air Temperature Sensor has the following specified calibration points, which are plotted in Fig. 36:

Temperature (°F)	Resistance Value (ohms)
98	11755
80	18478
70	24028
60	31525
42	52675

The T7770 Wall Module setpoint potentiometers have the following calibration points:

Temperature (°F)	Resistance Value (ohms)
85	1290
70	5500
55	9846

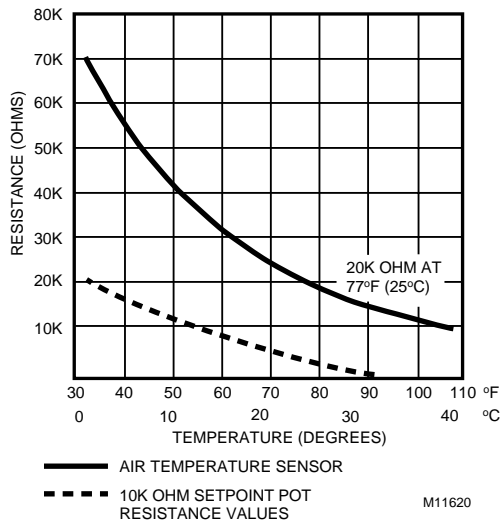

Fig. 36. Temperature sensor resistance plots.

### Alarms

When an Excel 10 has an alarm condition, it reports it to the central node on the E-Bus (typically, the Excel 10 Zone Manager). See Table 12. Information contained in an alarm message is:

- Subnet Number:  
E-Bus subnet that contains the Excel 10 node that has the alarm condition. Subnet 1 is on the Zone Manager side of the router; Subnet 2 is on the other side.
- Node Number:  
Excel 10 node that has the alarm condition (see Network Alarm).
- Alarm Type:  
Specific alarm being issued. An Excel 10 can provide the alarm types listed in Table 12.

Table 12. Excel 10 Alarms.

Name of alarm or error bit	Alarm type number	Meaning of alarm code or error bit
RETURN_TO_NORMAL	128U	Return to no alarm after being in an alarm condition. This code is added numerically to another alarm code to indicate that the alarm condition has returned to normal.
ALARM_NOTIFY_DISABLED	255U	The alarm reporting was turned off by DestManMode. No more alarms are reported until DestManMode turns on alarm reporting or on application restart.
NO_ALARM	0	No alarms presently detected.
INPUT_NV_FAILURE	1	One or more NV inputs have failed in receiving an update within their specified FAILURE_DETECT_TIME.
NODE_DISABLED	2	The control algorithm has stopped because the controller is in DISABLED_MODE, MANUAL or FACTORY_TEST mode. No more alarms are reported when the controller is in the DISABLED_MODE. Alarms continue to be reported if the controller is in the MANUAL or FACTORY_TEST mode.
SENSOR_FAILURE	3	One or more sensors have failed.

(continued)

Table 12. Excel 10 Alarms (continued).

Name of alarm or error bit	Alarm type number	Meaning of alarm code or error bit
FROST_PROTECTION_ALARM	4	The space temperature is below the frost alarm limit 42.8°F (6°C) when the mode is FREEZE_PROTECT. The alarm condition remains until the temperature exceeds the alarm limit plus hysteresis.
INVALID_SET_POINT	5	One of the Setpoints is not in the valid range.
LOSS_OF_AIR_FLOW	6	The Fan Status DI indicates that there is no air flow when the node is commanding the fan to run. The control is shut down and disabled until power is cycled or the node is reset. See NOTE below. The alarm is not issued until FanFailTime seconds have elapsed since the loss-of-flow condition was first reported.
DIRTY_FILTER	7	The pressure drop across the filter exceeds the limit and the filter requires maintenance. The control runs normally.
SMOKE_ALARM	8	The smoke detector has detected smoke and the node has entered an emergency state.
IAQ_OVERRIDE	9	The indoor air quality sensor has detected that the indoor air quality is poorer than the desired standard and additional outdoor air is being brought into the conditioned space.
LOW_LIM_ECON_CLOSE	10	The economizer has to close beyond the minimum position to prevent the discharge air temperature from going below the discharge temperature low limit.

NOTE: The node can be reset by switching the node to MANUAL and then to the normal operating mode.

Also, the Excel 10 variables, *AlarmLogX* where *X* is 1 through 5, that store the last five alarms to occur in the controller, are available. These points can be viewed through XBS or E-Vision.

Certain alarm conditions are suppressed conditionally as follows:

### Broadcasting the Service Message

The Service Message allows a device on the E-Bus to be positively identified. The Service Message contains the controller ID number and, therefore, can be used to confirm the physical location of a particular Excel 10 in a building.

There are two methods of broadcasting the Service Message from an Excel 10 W7750 Controller. One uses a hardware service pin button on the side of the controller (see Fig. 37). The other involves using the PC Configuration tool, as follows.

When an *Assign ID* command is issued from the commissioning tool, the node goes into the SERVICE\_MESSAGE mode for five minutes. In the SERVICE\_MESSAGE mode, pressing the Occupancy Override button on the remote wall module (refer to figure 39 for override button location) causes the Service Message to be broadcast on the network. All other functions are normal in the SERVICE\_MESSAGE mode. Even if an Excel 10 W7750 Controller does not have an Override button connected, it can broadcast the Service Message on the network by temporarily shorting the Controller Bypass Input terminal to the Sensor Ground terminal on the W7750A,B (short terminals 3 and 5).

The commissioning tool is used to perform the ID Assignment task (see the E-Vision User's Guide, form 74-2588).

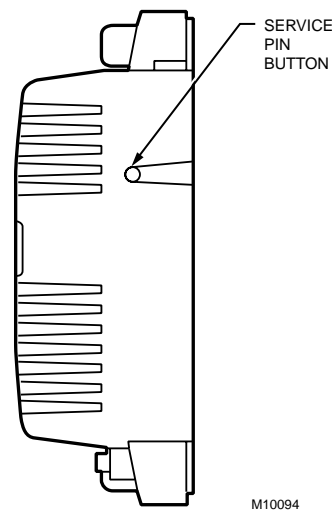

Fig. 37. Location of the Service Pin Button.

### W7750 Controller Status LED

The LED on the front and center of a W7750 Controller provides a visual indication of the status of the device. See Fig. 38. When the W7750 receives power, the LED should appear in one of the following allowable states:

1. Off—no power to the processor.
2. Continuously On—processor is in initialized state.
3. Slow Blink—controlling, normal state.
4. Fast Blink—when the Excel 10 has an alarm condition.

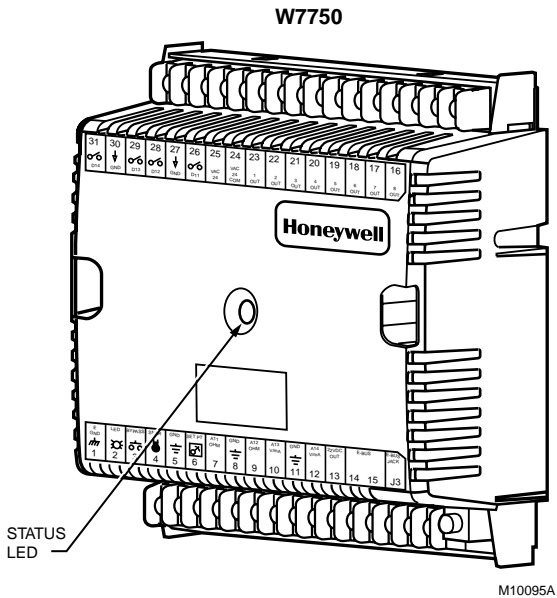

Fig. 38. LED location on W7750.

### T7770C,D Wall Module Bypass Pushbutton and Override LED

Pressing the bypass pushbutton, located on the T7770C,D Wall Modules in Fig. 39, causes the override LED to display the Manual Override mode of the controller. The modes are:

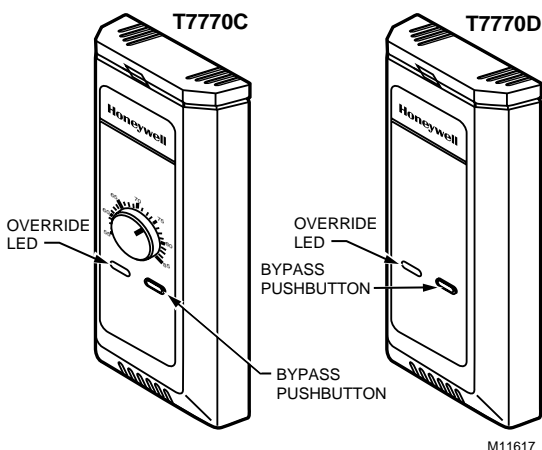

Fig. 39. The T7770C,D Wall Modules LED and Bypass pushbutton locations.

1. LED = Off. No override active.
2. LED = Continuously on. Bypass mode (timed Occupied override).
3. LED = One flash per second. Continuous Unoccupied override.
4. LED = Two flashes per second. Remote only, continuous Occupied override.

### T7780A DDWM Bypass Pushbutton and LCD Display Occupancy Symbols

See Fig. 40 for the T7780A DDWM bypass pushbutton location. The T7780A DDWM has two methods of generating its neuron ID.

1. Pressing the bypass pushbutton whenever a Carat (∇) on the bottom of the LCD display is flashing (Menu Selection Mode).
2. Pressing the bypass pushbutton when the T7780A DDWM is in wink mode (LCD display shows **WINK** when E-Vision sends a Service Message out on the E-Bus).

When the space covered by the T7780A DDWM is in Occupied mode, the sun symbol is shown on the left side of the LCD display. When the space is in Standby mode, the half-sun symbol is shown. When the space is in Unoccupied mode, the moon symbol is shown.

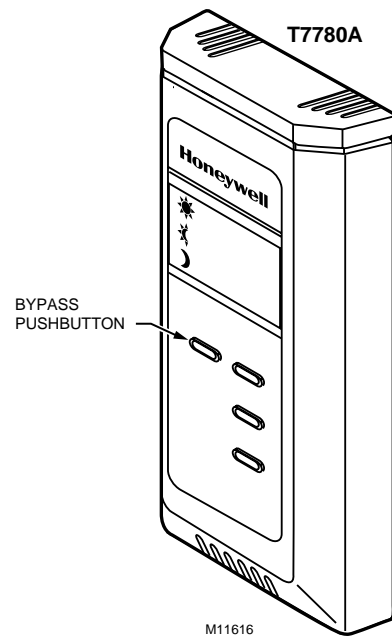

Fig. 40. The T7780A DDWM Bypass pushbutton location.

## APPENDICES

### Appendix A. Using E-Vision to Commission a W7750 Controller.

NOTE: When commissioning a CVAHU W7750 Controller, E-Vision first checks that the actual hardware model is (such as W7750A or W7750B) is the same type which was selected from the Application Selection/Output tab. If the types do not match, the download does not occur and the user-entered values in the Application Selection screens all revert back to default values.

#### Sensor Calibration

The space temperature, the optional resistive and *voltage/current* (W7750B only) inputs can all be calibrated. The wall module setpoint potentiometer *can not* be calibrated.

Perform the sensor calibration by adding an offset value (either positive or negative) to the sensed value using E-Vision menus (see E-Vision user guide, form number 74-2588).

When calibrating voltage/current sensors on the W7750B, the offset amount entered by the user is in volts, regardless of the inputs actual engineering units. See Appendix E for information on how to derive the proper voltage value to enter as an offset during calibration.

#### Setting the Pid Parameters

The W7750 is designed to control a wide variety of mechanical systems in many types of buildings. With this flexibility, it is necessary to verify the stability of the temperature control in each different type of application. Occasionally, the PID parameters require tuning to optimize comfort and smooth equipment operation. This applies to both W7750A and W7750B Controllers.

CVAHU Controllers are configured by E-Vision with default values of PID parameters that are based on the specific mechanical equipment controlled by the W7750. These default values (see Table A-1) are based on past experience with the applications and in most cases do not require further adjustment.

Table A-1. Default PID Parameters.

Equipment Configuration	Default Values Provided by E-Vision								
	Heat Prop. Gain	Heat Integ. Gain	Heat Deriv. Gain	Heat Control Band	Cool Prop. Gain	Cool Integ. Gain	Cool Deriv. Gain	Cool Control Band	Econ Control Band
Single Stage	2	3000	0	0	2	3000	0	0	0
Two Stages	3	2000	0	0	3	2000	0	0	0
Three Stages	4.5	1500	0	0	4.5	1500	0	0	0
Four Stages	6	1000	0	0	6	1000	0	0	0
Series 60 Mod-ulating (Floating)	2	750	0	15	2	750	0	15	15
PWM Modulating	2	900	0	15	2	900	0	15	15

If the PID parameters require adjustment away from these values, Use caution to ensure that equipment problems do not arise (see CAUTION below). If any change to PID control parameters is made, the adjustments should be gradual. After each change, the system should be allowed to stabilize so the effects of the change can be accurately observed. Then further refinements can be made, as needed, until the system is operating as desired.

### CAUTION

If large or frequent changes to PID control parameters are made, it is possible to cause equipment problems such as short cycling compressors (if the stage minimum run times were disabled in User Addresses DisMinCITime or DisMinHtTime). Other problems that can occur include wide swings in space temperature and excessive overdriving of modulating outputs.

If adjustment of PID parameters is required, use the following. In the items that follow, the term, error, refers to the difference between the measured space temperature and the current actual space temperature setpoint.

- The **Proportional Gain** (also called Throttling Range) determines how much impact the error will have on the output signal. Decreasing the Proportional Gain amplifies the effect of the error; that is, for a given error, a small Proportional Gain causes a higher output signal value.
- The **Integral Gain** (also called Integral Time) determines how much impact the error-over-time has on the output signal. Error-over-time has two components making up its value: the amount of time the error exists; and the size of the error. The higher the Integral Gain, the slower the control response. In other words, a decrease in Integral Gain causes a more rapid response in the output signal.

- The **Derivative Gain** (also called Derivative Time) determines how much impact the error rate has on the output signal. The error rate is how fast the error value is changing. It can also be the direction the space temperature is going, either toward or away from the setpoint, and its speed—quickly or slowly. A decrease in Derivative Gain causes a given error rate to have a larger effect on the output signal.
- The **Control Band** is used only for discharge temperature control of modulating outputs, which includes controlling the economizer dampers, and heating and cooling valves using Cascade Control. The Control Band dictates the span through which the discharge temperature must travel to cause the output signal to go from fully closed to fully open. Also, 10 percent of the Control Band value is the size of the *deadband* around the setpoint where no actuator motion occurs. For example, if controlling a cooling valve with Cascade Control enabled and with the discharge temperature within  $0.1 \times \text{DaTempCICtrlBd}$  of the discharge setpoint, there is no change in the current valve position. The smaller the Control Band, the more responsive the control output. A larger Control Band causes more sluggish control. Be careful not to set the Control Band too low and cause large over or under shoots (hunting). This can happen if the space or discharge sensors or wiring are in noisy environments and the value reported to the controller is not stable (such that it bounces). The Control Band is used only in modulating control, and has no purpose when staged control is configured.

## Appendix B. Sequences of Operation.

This Appendix provides the control sequences of operation for both models of the Excel 10 W7750 CVAHU Controller. The W7750A,B Controllers can be configured to control a wide variety of possible equipment arrangements. Table B-1 and B-2 (copied from Tables 3 and 4) summarize the available options. This Appendix provides a more detailed discussion of these options.

**Table B-1. Common Configuration Options Summary For Both W7750A And W7750B Controllers.**

Option	Possible Configurations Common to Both W7750 Models
<b>Supply Fan</b>	1. Mandatory Digital Output
<b>Type of Air Handler</b>	1. Conventional
	2. Heat Pump
<b>Occupancy Sensor</b>	1. None
	2. Connected: Contacts closed equals Occupied.
	3. Network (Occ/Unocc signal received via the E-Bus network).
<b>Window Sensor</b>	1. None
	2. Physically Connected: Contacts closed equals window closed.
	3. Network (Window Open/Closed signal received via the E-Bus).
<b>Wall Module Option</b>	1. Local (direct wired to the controller)
	2. Network (sensor value received via the E-Bus network).
<b>Wall Module Type</b> (All four types have an E-Bus access jack)	1. Sensor only
	2. Sensor and Setpoint adjust
	3. Sensor, Setpoint adjust and Bypass
	4. Sensor and Bypass
<b>Smoke Emergency Initiation</b>	1. None
	2. Physically Connected: Contacts closed equals smoke detected.
	3. Network (Emergency/Normal signal received via the E-Bus).

**Table B-2. Configuration Options Summary For W7750A And W7750B Controllers.**

Option	Possible Configurations for the W7750A Model	Possible Configurations for the W7750B Model
<b>Type of Heating</b>	1. One stage	1. One stage
	2. Two stages	2. Two stages
	3. Three stages	3. Three stages
	4. Four stages	4. Four stages
	5. None	5. Series 60 Modulating electric valve, or pneumatic via transducer.
		6. Pulse Width Modulating electric valve, or pneumatic via transducer.
		7. None
<b>Type of Cooling</b>	1. One stage	1. One stage
	2. Two stages	2. Two stages
	3. Three stages	3. Three stages
	4. Four stages	4. Four stages
	5. None	5. Series 60 Modulating electric valve, or pneumatic via transducer.
		6. Pulse Width Modulating electric valve, or pneumatic via transducer.
		7. None
<b>Type of Economizer</b>	1. Digital Output Enable/Disable signal for enabling an external economizer package.	1. Digital Output Enable/Disable signal for controlling an external economizer package.
	2. Series 60 Modulating electric damper motor, or pneumatic via transducer.	2. Series 60 Modulating electric damper motor, or pneumatic via transducer.
	3. None	3. Pulse Width Modulating electric damper motor, or pneumatic via transducer.
		4. None
<b>IAQ Option</b>	1. None	1. None
	2. Local IAQ Digital Input (directly wired to the controller).	2. Local IAQ Digital Input—directly wired to the controller. (Contacts closed means poor IAQ is detected.)
	3. Network (IAQ Override signal received via the E-Bus network).	3. Network (IAQ Override signal received via the E-Bus network).
		4. Local CO <sub>2</sub> Analog Input—directly wired to the controller. (The sensor must be a 0 to 10V device representing 0 to 2000 ppm CO <sub>2</sub> .)
<b>Filter Monitor Option</b>	1. None	1. None
	2. Local Dirty Filter Digital Input (directly wired to the controller).	2. Local Dirty Filter Digital Input—directly wired to the controller. (Contacts closed means that the filter is dirty.)
		3. Local Analog Input for Differential Pressure across the Filter (directly wired to the controller). The sensor must be a 2 to 10V device representing 0 to 5 inw (1.25 kPa).

**Common Operations**

The Excel 10 W7750 Controller applications have many common operations that are applicable regardless of the type of heating, cooling, or economizer equipment configuration. These operations are available to both the W7750A and the W7750B Versions of the CVAHU

Controller, and the I/O and network configurations for them are summarized in Table B-1.

Available input options are from the wall module and the hard-wired analog and digital inputs. Each application can have only a subset of these devices configured based on the number of physical I/O points available. However, some of the inputs are available over the E-Bus network.

NOTE: Each W7750 Controller *must* have a space temperature sensor input either wired directly to the controller, or shared from another E-Bus device, and must have a digital output configured for controlling the supply fan. In addition, if modulating economizer control is desired, a discharge air temperature sensor *must* be physically connected to the Excel 10 W7750 Controller. A discharge temperature signal *cannot* be brought into the controller through the E-Bus network.

#### Room Temperature Sensor (RmTemp)

This is the room space temperature sensor. This sensor is the T7770 Wall Module or the T7780A DDWM. When it is configured, it provides the temperature input for the W7750 temperature control loop. If it is not configured, it is required that a room temperature sensor value be transmitted from another E-Bus device like the T7780A DDWM. If no valid room temperature value is available to the W7750 Controller, the temperature control algorithm in the controller is disabled, causing the heating, cooling, and economizer control outputs to be turned off. If the W7750 Controller is configured for Continuous Fan (rather than Intermittent Fan (see Fan Operation in this Appendix), and the mode is Occupied when the RmTemp value becomes invalid, the fan continues to run.

#### Remote Setpoint (RmtStptPot)

This is the Setpoint Potentiometer contained in the T7770 Wall Module. (The T7780A DDWM must be in Setpoint to change a controllers setpoint via the E-Bus. Press the up or down arrow keys once or press the enter key twice to get the T7780A DDWM in Setpoint.) When configured, this occupant value is set to calculate the actual cooling or heating Occupied Setpoint. There are two options for how to calculate the actual setpoint to be used by the temperature control algorithm: (Offset) and (Absolute Middle). When SetPtKnob is set to Offset, the Wall Module setpoint knob represents a number from -9° to +9°F (-5° to +5°C) which is added to the software occupied setpoints for the heat and the cool modes (CoolOccSpt and HeatOccSpt). When SetPtKnob is set to Absolute Middle, the setpoint knob becomes the center of the Zero Energy Band (ZEB) between the cooling and heating occupied setpoints. The size of the ZEB is found by taking the difference between the software heating and cooling occupied setpoints; therefore, for Absolute Middle, the actual setpoints are found as follows:

$$\text{ActualCoolSpt} = \text{RmtStptPot} + (\text{CoolOccSpt} - \text{HeatOccSpt}) / 2$$

$$\text{ActualHeatSpt} = \text{RmtStptPot} - (\text{CoolOccSpt} - \text{HeatOccSpt}) / 2$$

During Standby and Unoccupied times, the remote setpoint pot is not referenced, and the software setpoints for those modes are used instead.

#### Setpoint Limits (LoSetptLim and HiSetptLim)

Remote setpoint pot limits are provided by LoSetptLim and HiSetptLim. The occupied setpoints used in the control algorithms are limited by these parameters. When the setpoint knob is configured to be of type Absolute Middle, the lowest actual setpoint allowed is equal to LoSetptLim, and the highest actual setpoint allowed is equal to HiSetptLim. When the setpoint knob is configured to be an Offset type, the lowest actual setpoint allowed is equal to HeatOccSpt -

LoSetptLim, and the highest allowed is equal to CoolOccSpt + HiSetptLim.

#### Bypass Mode (StatusOvrd and StatusLed)

During Unoccupied periods, the facility occupant can request that Occupied temperature control setpoints be observed by depressing the Bypass pushbutton on the wall module.

When activated, the controller remains in Bypass mode until:

1. Bypass Duration Setting has timed out (BypTime), or
2. User again presses the Wall Module pushbutton to switch off Bypass mode, or
3. Occupancy schedule (SchedOcc network input or TimeClkOcc digital input) switches the mode to Occupied.
4. User sets the DestManualOcc network point to Not Assigned.

The LED on the Wall Module (StatusLed) indicates the current bypass mode status (see the T7770C,D Wall Module Override LED section).

#### BypassTime

BypassTime is the time between the pressing of the override button at the wall module (or initiating OC\_BYPASS via nviManOcc) and the return to the original occupancy state. When the bypass state has been activated, the bypass timer is set to BypassTime (default of 180 minutes).

#### OverrideType

OverrideType specifies the behavior of the override button on the wall module. There are three possible states that have the following meanings:

NONE disables the override button.

NORMAL causes the override button to set the OverRide state to OC\_BYPASS for BypassTime (default 180 minutes), when the override button has been pressed for approximately 1 to 4 seconds, or to set the OverRide state to UNOCC when the button has been pressed for approximately 4 to 7 seconds. When the button is pressed longer than approximately 7 seconds, then the OverRide state is set to OC\_NUL (no manual override is active).

BYPASS\_ONLY causes the override button to set the OverRide state to OC\_BYPASS for BypassTime (default 180 minutes), on the first press (1 to 7 seconds). On the next press, the OverRide state is set to OC\_NUL (no manual over ride is active).

#### OverridePriority

OverridePriority configures the override arbitration between nviManOcc, nviBypass.state, and the wall module override button. There are two possible states which have the following meanings:

LAST specifies that the last command received from either the wall module or nviManOcc determines the effective override state.

NET specifies that when nviManOcc is not OC\_NUL, then the effective occupancy is nviManOcc regardless of the wall module override state.

**Cycles per Hour (ubHeatCph and ubCoolCph)**

ubHeatCph specifies the mid-load number of on / off cycles per hour (default is 6), when the mode is HEAT. ubCoolCph specifies the mid-load number of on / off cycles per hour (default is 3), when the mode is COOL. This is to protect the mechanical equipment against short cycling causing excessive wear. In addition the cycle rate specifies the minimum on and off time according to Table B-3.

**T7770C,D or T7780A DDWM Bypass Pushbutton Operation**

The Wall Module Bypass pushbutton, located on both the T7770C,D Wall Modules, see Fig. 39 and the T7780A DDWM, see Fig. 40, can change the controller into various occupancy modes as follows:

If Pushbutton is Held Down for at Least	The But for Not More than	Resulting Mode is
<1 second	1 second	No Override active
1 second	4 seconds	Bypass mode (timed Occupied override)
4 seconds	7 seconds	Continuous Unoccupied override

NOTES: If pushbutton is held down for longer than seven seconds, the controller reverts back to No Override and repeats the cycle above. See Fig. B-0.

Continuous Occupied override mode can only be initiated remotely; that is, over the E-Bus network.

An error condition is displayed as three short blinks and one long blink when the Bypass pushbutton is held down or shorted. The short must be removed to return the controller to proper operation.

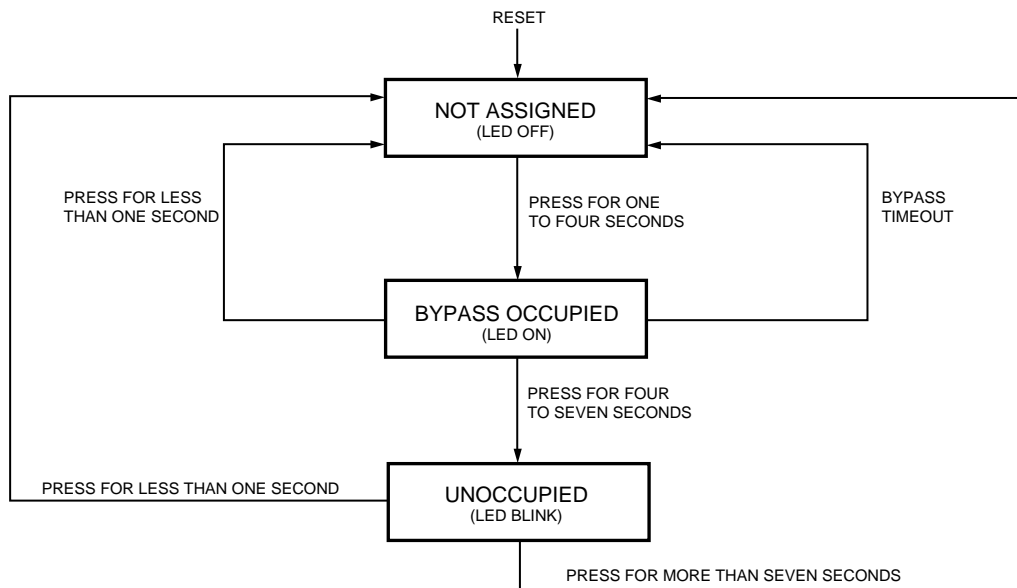

M8483A

**Fig. B-0. LED and Bypass pushbutton operation.**

**Standby Mode (StatusOcySen)**

The digital input for an occupancy sensor (usually a motion detector or possibly a time clock) provides the controller with a means to enter an energy-saving Standby mode whenever people are not in the room. Standby mode occurs when the scheduled occupancy is Occupied, and the occupancy sensor detects no people currently in the room (digital input contacts Closed means people are in the room, and contacts

Open means the room is Unoccupied). When in Standby mode, the Excel 10 W7750 Controller uses the Standby Cooling Setpoint for cooling (CoolStbySpt), or the Standby Heating Setpoint for Heating (HeatStbySpt) as the Actual Space Temperature Setpoint. The occupancy sensor signal can also be a network input from another E-Bus device, so that no physical sensor is required at the receiving W7750 Controller.

**IMPORTANT**

*When the W7750 Controller is in Standby mode, the economizer minimum position setting is not observed. This means the fresh air dampers will go fully closed if there is no call for cooling.*

**Continuous Unoccupied Mode**

This mode is entered when a wall module is configured with a Bypass pushbutton that was pressed for four to seven seconds causing the wall module LED to blink. This mode can also be entered via a network command (ManualOcc set to Unoccupied). If the controller is in this mode, it reverts to the Unoccupied setpoints for temperature control, and the economizer does not observe its minimum position setting. The controller remains in this mode indefinitely until the Bypass pushbutton is pressed to exit the mode or a network command is sent to clear the mode. A configuration parameter is available to disable wall-module initiation of Continuous Unoccupied mode (OvrType).

The three sources of manual override status are:

- DestManualOcc - Has possible states: Occupied, Unoccupied, Bypass, Standby and Not Assigned (not active). This input source has the highest priority in determining manual override status for a Network Wins arbitration scheme, and in the event there is more than one source change at a time in the Last-in Wins arbitration scheme. Here, bypass initiates a self-timed bypass of the control unit and expires upon completion of the defined timed period. The controller then treats the bypass status of this input as Not Assigned until the next change in status.
  - DestBypass - Has possible states: Bypass On, Bypass Off or Not Assigned (not active). This input places the controller in an *untimed* bypass state or turns off the bypass mode. This source is second in priority to DestManualOcc under the same arbitration schemes mentioned above.
  - Override Button - The wall module Override pushbutton can command status of Bypass, Continuous Unoccupied and Not Assigned. This source has the lowest priority status in the above mentioned schemes. The above mention sources of override must be either Not Assigned or Off before the Override pushbutton affects the manual override status in the Network Wins scheme. All actions, in this case, taken from the Override pushbutton are locked out.
- Bypass status is a controller-timed event whose duration is set in BypTime. Upon expiration of the timer, the status returns to Not Assigned. The status of this input can be overridden with the receipt of Not Assigned from DestManualOcc. This, in effect, cancels a timed bypass or a continuous unoccupied mode.
- The Override pushbutton can be configured as Normal (all of the above mentioned states are possible), Bypass Only (Bypass and Not Assigned only) or None (effectively Disabling the Override pushbutton).

**Occupancy Mode and Manual Override Arbitration**

The W7750 has multiple sources for occupancy schedule information and, therefore, it employs an arbitration scheme to determine the current actual mode. Time-of-day (TOD) schedule status comes from two sources, a configured digital input for OccTimeClock or the SchedOcc network input received from a central control. If the digital input source is configured, it has highest priority and determines the Occupancy mode. This digital input is either ON (shorted = occupied), OFF (open = unoccupied), or not active (not configured); otherwise, the status is determined by the SchedOcc input from the network source. The SchedOcc has three possible states, occupied, unoccupied or standby.

Manual Override Status can be derived from three sources and governed by two selectable arbitration schemes. The two schemes are:

Network Wins or Last-in Wins, as set in OvrPriority.

**Time Clock (Occ\_Time\_Clock)**

OccTimeClock is the state of the digital input configured and wired to a time clock. When the digital input is detected to be Closed (Occupied), the scheduled occupancy will be OC\_OCCUPIED. If the detected state of the digital input is Open (Unoccupied), then the scheduled occupancy will be OC\_UNOCCUPIED. If the Occ\_Time\_Clock is not configured, then either the SchedOcc network input received from a central control or the time clock that is broadcast from a Sched\_Master configured W7750, will control the occupied mode.

**Schedule Master (Sched\_Master)**

Sched\_Master is the state of a digital input that is configured and wired to the W7750. If the Sched\_Master input is closed (input shorted), the node is the schedule master and the state of the locally connected time clock will be broadcast out over the E-Bus to the other W7750 controllers. If the Sched\_Master input is open, then the node is not a schedule master and the local time clock will not be sent out over the E-Bus even if the time clock input is configured. However, the SchedOcc network input received from a central control will have a higher priority than the local time clock, and therefore override the local time clock. The W7750 controllers will automatically bind without the need for a configuration tool.

**Setpoint Ramping**

The W7750 Controller incorporates a ramping feature that gradually changes the space setpoints between occupancy modes. This feature is only operational if the network variable inputs SchedOcc, TodEventNext, and Time Until Next Change Of State (TUNCOS) are being used to change the W7750 Occupancy mode. The applicable Setpoints are OaTempMinHtRamp, OaTempMaxHtRamp, MinHtRamp and MaxHtRamp (for HEAT mode operation), and OaTempMinCIRamp, OaTempMaxCIRamp, MinCIRamp and MaxCIRamp (for the COOL mode operation). See Fig. B-1 for a pictorial representation of how these setpoints interact.

During recovery operation, the setpoint changes at a rate in degrees per hour depending on the outdoor air temperature. If there is no outdoor air temperature sensor available, then MinHtRamp is used as the recovery rate.

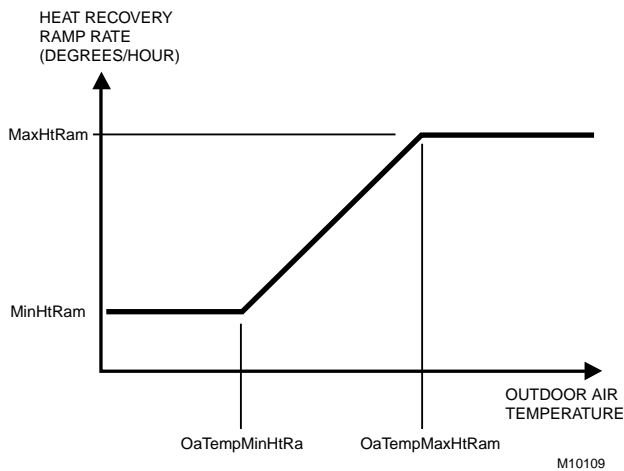

**Fig. B-1. Setpoint ramping parameters with ramp rate calculation.**

**NOTE:** Recovery ramping applies between scheduled heating or cooling setpoint changes from UNOCCUPIED to STANDBY, UNOCCUPIED to OCCUPIED, and STANDBY to OCCUPIED. Scheduled setpoint changes from OCCUPIED to UNOCCUPIED or OCCUPIED to STANDBY do not use a ramped setpoint but instead use a step change in setpoint. Recovery ramps begin before the next scheduled occupancy time and are ramped from the setpoint for the existing scheduled occupancy state to the setpoint for the next occupancy state.

**Recovery Ramping for Heat Pump Systems**

When the node is controlling heat pump equipment, during the recovery ramps, the heating setpoint is split into a heat pump setpoint (for compressors) and an auxiliary heat setpoint (for auxiliary heat stages). The heat pump setpoint is a step change at the recovery time prior to the OCCUPIED time. Recovery time is computed from the configured heat recovery ramp rate. The recovery time is calculated:

$$\text{Recovery time} = (\text{OCC setpoint} - \text{current setpoint}) / \text{ramp rate}$$

See Fig. B-2 for the various setpoints.

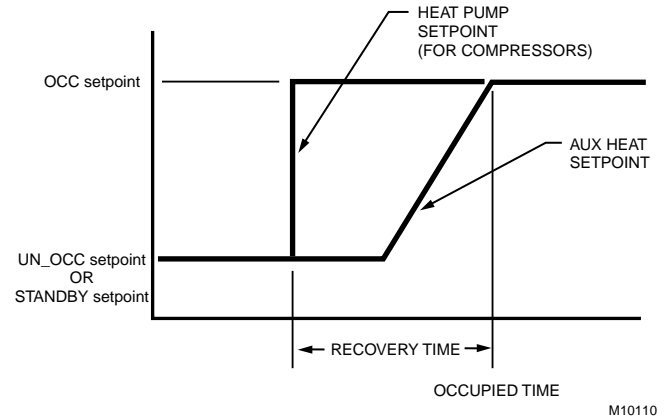

**Fig B-2. Setpoint ramping parameters with setpoint calculation.**

During the COOL recovery period, the setpoint changes at a rate in degrees per hour relative to the outdoor air temperature. If there is no outdoor air temperature sensor available, the MinCIRamp is used as the recovery rate.

See Fig. B-3 for the various setpoints.

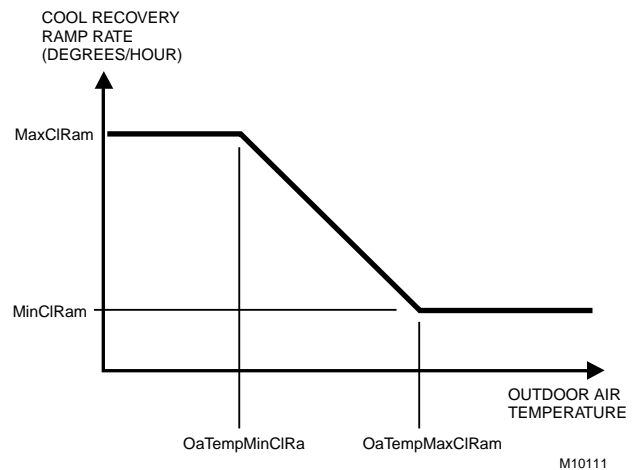

**Fig. B-3. Setpoint ramping parameters with ramp rate calculation.**

NOTES: The setpoint used during the COOL recovery period is similar to the heat mode in Fig. B-1, except the slope of the line reverses for cooling.

Recovery ramping applies between scheduled heating or cooling setpoint changes from UNOCCUPIED to STANDBY, UNOCCUPIED to OCCUPIED, and STANDBY to OCCUPIED. Scheduled setpoint changes from OCCUPIED to UNOCCUPIED or OCCUPIED to STANDBY do not use a ramped setpoint, but instead, use a step change in setpoint. Recovery ramps begin before the next scheduled occupancy time and are ramped from the setpoint for the existing scheduled occupancy state to the setpoint for the next occupancy state.

### Fan Operation

The W7750 supply fan can be controlled in one of two different ways. In Continuous Fan mode, the fan runs whenever the controller is in Occupied mode. When in Standby or Unoccupied modes, the fan cycles on with a call for cooling (or heating if the FanOnHtMode parameter is set). In Intermittent Fan mode, the fan cycles on with a call for cooling (or heating if the FanOnHtMode parameter is set), and cycles off when the space temperature control is satisfied.

The fan control supports an optional (Proof of Air Flow) digital input, that allows monitoring of the supply fans status. If the fan is commanded on, the Proof of Air Flow digital input is checked up to three times to verify that the fan is running *after* an initial delay of FanOnDelay seconds (user-settable). If the fan fails to start the CVAHU must be reset by first cycling CVAHU power. If this does not work, set DestManMode to Manual and then back to Enable. After a reset the application restarts—all outputs switch off and auto control is enabled.

Also, the W7750 Controller provides fan-run-on operation that keeps the fan running for a short time after heating or cooling shuts off. The amount of time that the fan continues to run is set in FanRunOnHeat for heating mode and FanRunOnCool for cooling mode.

### Window Sensor (StatusWndw)

The digital input for a window contact provides the algorithm with a means to disable its temperature control activities if someone has opened a window or door in the room. When a window is detected to be Open (digital input contacts Open equals window open), the normal temperature control is disabled, and the W7750 Controller enters the Freeze Protect mode. Freeze Protect mode sets the space setpoint to 46.4 °F (8°C) and brings on the fan and heat if the space temperature falls below this setpoint. Normal temperature control resumes on window closure. The Window sensor signal can also be a network input from another E-Bus device, so that no physical sensor is required at the receiving W7750 Controller.

### Smoke Control

The Excel 10 W7750 Controller supports three smoke-related control strategies:

1. Emergency Shutdown (all outputs off).

2. Depressurize (fan on, outdoor air damper closed).
3. Pressurize (fan on, outdoor air damper open).

The controller is placed in one of these three control states whenever the W7750 mode becomes SMOKE\_EMERGENCY, which can be initiated via a network command (DestEmergCmd) or from a local (physically connected) smoke detector digital input. When in SMOKE\_EMERGENCY mode, the W7750 Controller uses the control strategy found in SmkCtlMode (one of the three listed above), and the normal temperature control function is disabled. If a W7750 local smoke detector trips, the SrcEmerg network variable (for other E-Bus devices to receive) is set to the Emergency state.

### Demand Limit Control (DLC)

When The E-Bus network receives a high-electrical-demand signal, the controller applies a DlcBumpTemp amount to the current actual space temperature setpoint value. The setpoint is always adjusted in the energy-saving direction. This means that if the W7750 Controller is in Cooling mode, the DLC offset bumps the control point up, and when in Heating mode, bumps the control point down.

### Dirty Filter Monitor

The air filter in the air handler can be monitored by the W7750 and an alarm issued when the filter media needs replacement. The two methods of monitoring the filter are:

1. A differential pressure switch whose contacts are connected to a digital input on the W7750A or W7750B; and
2. A 2-to-10V differential pressure sensor wired to a current input on the W7750B. If the analog input sensor is used, its measured value 0 to 5 inw (0 to 1.25 kPa) is compared to a user-selectable setpoint (FltrPressStPt—valid range: 0 to 5 inw (0 to 1.25 kPa)), and the Dirty Filter alarm is issued when the pressure drop across the filter exceeds the setpoint.

### Start-Up

START\_UP\_WAIT is the first mode after application restart or power-up. During START\_UP\_WAIT, the analog and digital inputs are being read for the first time, no control algorithms are active, and the physical outputs (fan and heat/cooling stages) are in the de-energized position. The node remains in the START\_UP\_WAIT mode for a pseudo-random period (depending on neuron\_id) between 12 and 22 seconds and then transitions to one of the operating modes, depending on the inputs that are read from the physical and network inputs. The pseudo random period prevents multiple controllers from simultaneously starting major electrical loads when power is restored to a building.

NOTES: After a controller download via Care/E-Vision, the delayed reset time is bypassed and the controller starts after a 40-second initialization.

Not all network inputs can be received during the START\_UP\_WAIT period because many network variables are updated at a slower rate; therefore some control decisions can be considered temporarily inappropriate.

## Temperature Control Operations

See Fig. B-4 for a diagram of a typical W7750 Unit.

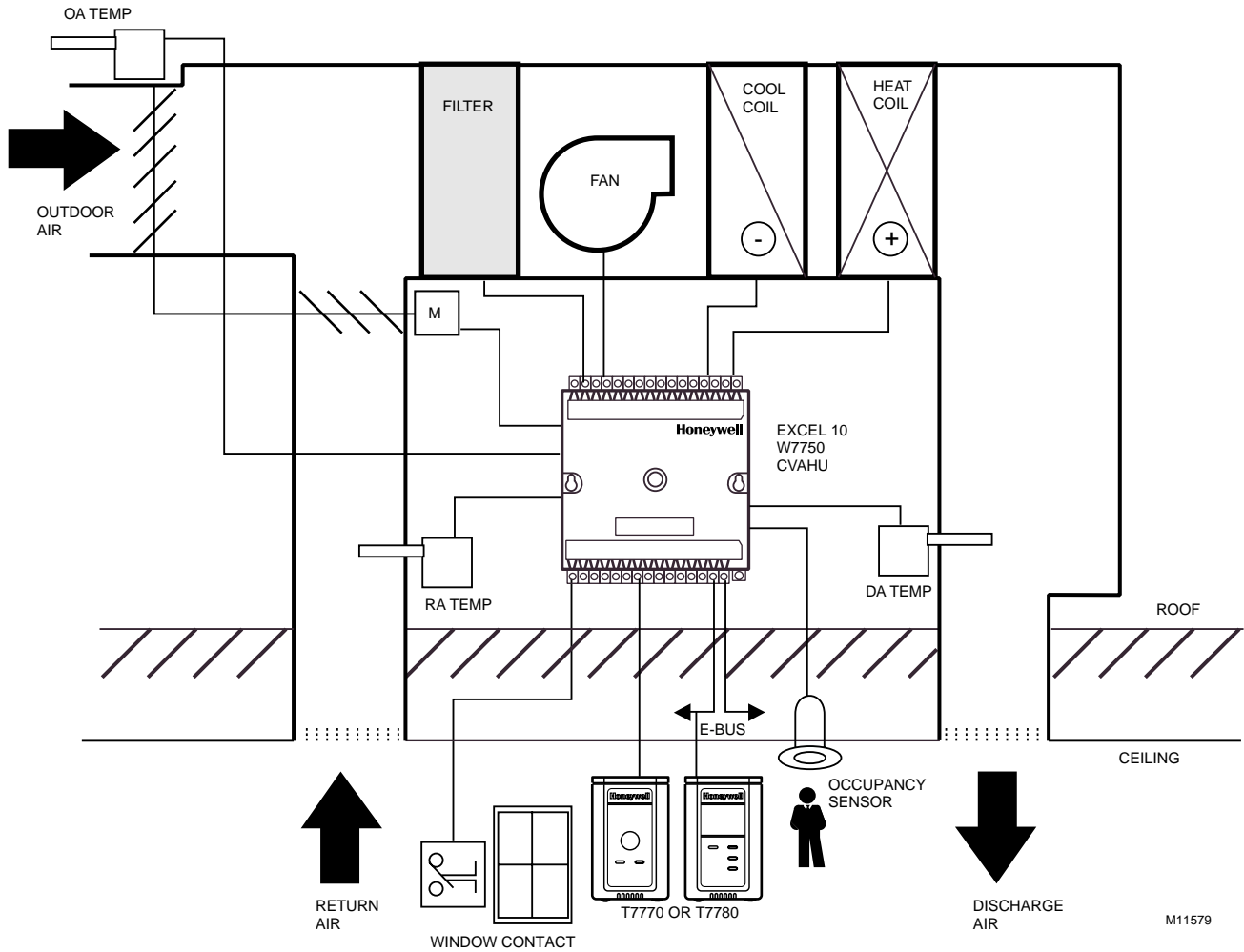

Fig. B-4. Schematic diagram for a typical W7750B Unit.

### Staged Cooling Control

The Excel 10 W7750 Controller supports up to four stages of D/X cooling. As space temperature rises above the current Cooling Setpoint, the controller's mode of operation is switched to the COOL mode. When in the COOL mode, all heating outputs are driven closed or off (with the exception that occurs during IAQ Override Operation, see above), and the staged cooling outputs are enabled for use. When in the COOL mode, the PID cooling control algorithm compares the current space temperature to the EffectiveCoolSetPt, and

calculates a PID error signal. This error signal causes the cooling stage outputs to be cycled as required to drive the space temperature back to the setpoint. Figure B-5 illustrates the relationship between PID error and staged output activity. As the error signal increases and the space temperature is getting farther away from setpoint, or is remaining above setpoint as time elapses, additional stages of cooling are energized until, if PID error reaches 100 percent, all configured stages are on.

NO. STAGES CONFIGURED \ PID ERROR	PID ERROR							
	0%	25%	33%	50%	66%	75%	100%	> 100%
<b>ONE STAGE</b>	CYCLING							ALL STAGES LOCKED ON
<b>TWO STAGES</b>	STAGE 1 CYCLING			STAGE 1 LOCKED ON STAGE 2 CYCLING				ALL STAGES LOCKED ON
<b>THREE STAGES</b>	STAGE 1 CYCLING		STAGE 1 LOCKED ON STAGE 2 CYCLING			STAGE 1,2 LOCKED ON STAGE 3 CYCLING		ALL STAGES LOCKED ON
<b>FOUR STAGES</b>	STAGE 1 CYCLING	STAGE 1 LOCKED ON STAGE 2 CYCLING		STAGE 1,2 LOCKED ON STAGE 3 CYCLING		STAGE 1,2,3 LOCKED ON STAGE 4 CYCLING		ALL STAGES LOCKED ON

M10112

Fig. B-5. Staged output control versus PID Error.

If economizer dampers are configured, and the outdoor air is suitable for free cooling, the economizer operates as the first stage of cooling. For example, if a controller was configured with two stages of mechanical cooling and an economizer, the application should be viewed in Fig. B-5 as a *three-stage* system.

Setpoints for the PID gains allow for unit-by-unit adjustment of the control loop, if required; however, any change from the default values should be minimal.

The PID control algorithm used to control staged cooling is anticipator-driven, and is similar to the algorithm used in the T7300 commercial thermostat. All staging events are subject to a minimum interstage time delay, which is based on the cycles per hour user setting (CoolCycHr). The minimum interstage time delay ranges from 90 seconds (at 12 cycles per hour) to 8.5 minutes (at two cycles per hour), see Table B-3. The user has the option to disable the minimum run timer (DisMinCITimer for cooling). If the minimum run timer is disabled, the interstage time delay is fixed at 20 seconds. The cycling rate is separately selectable for heating and cooling between 2 and 12 cycles per hour (cph).

Table B-3. Interstage Minimum Times

Cycles/Hour Selection	Minimum On/Off Time (Minutes)
2	8.5
3	5.5
4	4.0
5	3.5
6	3.0
7	2.5
8	2.0
9	2.0
10	2.0
11	1.5
12	1.5

**Staged Heating Control**

The Excel 10 W7750 Controller supports up to four stages of heating. As space temperature falls below the current Cooling Setpoint, the controller mode of operation is switched to the HEAT mode. When in the HEAT mode, all cooling outputs are driven closed or off, and the staged heating outputs are enabled for use. When in the HEAT mode, the PID cooling control algorithm compares the current space temperature to the EffectiveHeatSetPt, and calculates a PID error signal. This error signal causes the heating stage outputs to be cycled, as required, to drive the space temperature back to the Setpoint. Fig. B-5 illustrates the relationship between PID error and staged output activity.

As the error signal increases, the space temperature gets further away from the setpoint, or is remaining below the setpoint as time elapses, additional stages of heating are energized until, if PID error reaches 100 percent, all configured stages are on.

The PID control algorithm used to control staged heating is anticipator-driven, and is similar to the algorithm used in the T7300 commercial thermostat. All staging events are subject to a minimum interstage time delay, that is based on the cycles per hour user setting (HeatCycHr). The minimum interstage time delay ranges from 90 seconds (at 12 cycles per hour) to eight minutes (at two cycles per hour). See Table B-3. The user has the option to disable the minimum run timer for heating (DisMinHtTimer). If the minimum run timer is disabled, the interstage time delay is fixed at 20 seconds. The cycling rate is separately selectable for heating and cooling between two and 12 cycles per hour (cph).

Setpoints for the PID gains allow for unit-by-unit adjustment of the control loop, if required; however, any change from the default values should be minimal.

#### Cascade Control of Modulating Cooling/Heating

The Excel 10 W7750 Controller supports modulating cooling and heating valves. These valves can be controlled directly from the space temperature (like the staged control) or, if the CascCtrl flag is set, they are modulated to maintain the discharge air temperature at its setpoint. The discharge air setpoint is calculated based on the space temperature deviation from the space setpoint. This is commonly called cascade control. In the W7750 Controller, cascade control is available for use with Series 60 and PWM modulating heating and cooling, but not for use with staged heating/cooling.

Setpoints for the PID gains and for the control band allow for unit-by-unit adjustment of the control loops, if required; however, any change from the default values should be minimal. Also, the W7750 Controller uses an adaptive algorithm (patent pending) to continuously assess the validity of the calculated discharge setpoint, and adjust it, as needed, to ensure precise, accurate control.

#### Series 60 Modulating Control

Series 60 Control is also commonly referred to as Floating Control. The Excel 10 W7750B Controller can drive Series 60 type actuators to control a modulating cooling valve, a heating valve, and economizer dampers (the W7750A can control a floating economizer damper, but not floating heating or cooling). When floating control is used, the full-stroke motor drive time of the actuator must be entered into the configuration parameter CoolMtrSpd (for cooling), HeatMtrSpd (for heating), or EconMtrSpd (for the economizer dampers).

#### Pulse Width Modulating (PWM) Control

The Excel 10 W7750B Controller can drive a PWM-type actuator to control a modulating cooling valve, a heating valve, and economizer dampers. PWM control positions the actuator based on the length, in seconds, of the pulse from the digital output. The controller outputs a pulse whose length consists of two parts, a minimum and a maximum. The minimum pulse time represents the analog value of zero

percent (also indicates a signal presence) and the maximum pulse length that represents an analog value of 100 percent. If the analog value is greater than zero percent, an additional time is added to the minimum pulse time. The length of time added is directly proportional to the magnitude of the analog value. If PWM control is used, the configuration parameters for the PWM operation must be specified. These are PwmPeriod, PwmZeroScale, and PwmFullScale. These three parameters are shared by all configured PWM outputs; this means the heating, cooling, and economizer actuators must be configured to accept the same style of PWM signal.

**Example:** To find the pulse width of a valve actuator (for example stroke mid position - 50 percent) with the PwmZeroScale = 0.1 seconds, PwmFullScale = 25.5 seconds, and the PwmPeriod = 25.6 seconds. There are 256 increments available, so the number of increments required for 50 percent would be  $(0.5 \times 256)$  or 128. The time for each increment for this industry standard pulse time is 0.1 seconds. The pulse width is the minimum time (0.1 second) + the number of increments (128 times the seconds added  $0.1 \times 128 = 12.9$  seconds). The W7750B controller would command the valve output on for 12.9 seconds every 25.6 seconds to maintain the valve position at 50 percent.

#### Outdoor Air Lockout of Heating/Cooling

A mechanism is provided in the W7750 to disable the heating equipment if the outdoor air temperature rises above the OaTempHtLkOut setpoint. Similarly, the cooling equipment is disabled if the outdoor air temperature falls below the OaTempClkOut setpoint. The algorithm supplies a fixed 2°F (1.1°C) hysteresis with the lock-out control to prevent short cycling of the equipment.

#### Economizer Damper Control

A mixed-air economizer damper package can be controlled to assist mechanical cooling in maintaining the discharge air at setpoint. Therefore, if modulating economizer damper control is desired, a discharge air temperature sensor is required. If the outdoor air is not currently suitable for cooling use (see the Economizer Enable/Disable Control section), the outdoor air damper is held at the user-settable minimum position (EconMinPos) for ventilation purposes.

Because the outdoor air can be used to supplement mechanical cooling, the economizer operates as if it were the first stage of cooling. So, if the outdoor air is suitable for cooling use, the mechanical cooling (either staged or modulating) is held off until the economizer has reached its fully open position. Then, if the discharge temperature continues to be above setpoint, the mechanical cooling is allowed to come on. If the outdoor air is *not* suitable for cooling use, the economizer is set to its minimum position, and mechanical cooling is allowed to come on immediately.

When the controller is in the Heat mode, the economizer is held at the minimum position setting (EconMinPos). The minimum position setting is only used during Occupied mode operation. When in Standby or Unoccupied modes, the outdoor air dampers are allowed to fully close if there is no call for cooling, or if the outside air is not suitable for cooling use.

**Indoor Air Quality (IAQ) Override**

The Excel 10 W7750 Controller supports an IAQ override feature that upon detection of poor air quality in the space, allows the economizer dampers to be opened above the standard minimum position setting to a value set in EconIAQPos. Two different methods of detecting poor air quality are supported. The first is by using an IAQ switch device connected to a digital input on the W7750 Controller, where a contact closure indicates poor air quality and initiates the IAQ override mode. The second, which is only available on the W7750B, is through an analog input that connects to a CO<sub>2</sub> Sensor (0 to 10V). The measured value of CO<sub>2</sub> from this sensor (0 to 2000 ppm) is compared to the setpoint IAQSetpt. When the CO<sub>2</sub> level is higher than the setpoint, the IAQ override is initiated.

When the W7750 Controller is in the COOL mode during an IAQ override, it is possible for the heating outputs to be activated. This can occur if the outdoor air temperature is cold enough to cause the discharge air temperature to drop below the DaTempLoLim setpoint when the dampers open to the EconIAQPos position, and the laqUseHeat flag is set. If this situation occurs, the heating is controlled to maintain the discharge air temperature at 1°F (0.65°C) above the DaTempLoLim setpoint.

**Discharge Air Low Limit Control**

If the discharge air temperature falls below the user-settable discharge air low limit setpoint (DaTempLoLim), an alarm is issued, and the outdoor air damper is driven below the minimum position setting until the discharge temperature is up to the low limit. If necessary, the damper can go completely closed even during Occupied mode operation. As the discharge temperature warms up, the economizer modulates open until the minimum position setting is reached. At this point, the low limit alarm is cleared.

**Economizer Enable/Disable Control**

The W7750 Controller has inputs to determine if the outdoor air is suitable to augment cooling. The economizer dampers can be enabled/disabled for using outdoor air as the first stage of cooling based on one of ten allowable strategies:

1. **Digital Input En/Disable**—contact closure enables economizer.
2. **Outdoor Temperature**—when the outdoor temperature is less than OaEconEnTemp, then the outdoor air is suitable to augment cooling.

3. **Outdoor Enthalpy, Type A**—when the outdoor enthalpy meets the H205 type A requirements, the outdoor air is suitable to augment cooling.
  4. **Outdoor Enthalpy, Type B**—when the outdoor enthalpy meets the H205 type B requirements, the outdoor air is suitable to augment cooling.
  5. **Outdoor Enthalpy, Type C**—when the outdoor enthalpy meets the H205 type C requirements, the outdoor air is suitable to augment cooling.
  6. **Outdoor Enthalpy, Type D**—when the outdoor enthalpy meets the H205 type D requirements, the outdoor air is suitable to augment cooling.
  7. **Differential Temperature**—the difference between outdoor temperature and return air temperature is compared to DiffEconEnTemp to determine whether outdoor air or return air is more suitable for use to augment mechanical cooling.
  8. **Single Calculated Enthalpy**—the calculated outdoor enthalpy in btu/lb is compared to the enthalpy setpoint (OaEnthEn) in btu/lb, and the outdoor temperature is compared to the outdoor temperature limit setpoint (OaEconEnTemp) for a high limit. The compared difference determines whether outdoor air is suitable for use to augment mechanical cooling.
  9. **Differential Enthalpy, Either Sensed or Calculated**—the difference between outdoor enthalpy and return air enthalpy determines whether outdoor air or return air is more suitable to augment mechanical cooling. When enthalpy sensors are configured, they are used for comparing enthalpy. If no enthalpy sensors are available, then enthalpy is calculated using outdoor and return air humidity and temperature sensors. The switching differential is fixed at 1.0 mA for enthalpy sensors, and 0.25 btu/lb for calculated enthalpy.
- NOTE: If no return temperature sensor is configured, space temperature is used to calculate return air enthalpy.
10. **Network Enabled**—the network input (EconInValue) controls the enabling and disabling of the economizer.

**Appendix C. Complete List of Excel 10 W7750 Controller User Addresses.**

Table C-0 lists the applicable Engineering Units for the analog points found in the W7750.

**Table C-0. Engineering Units For Analog Points.**

Measured Item	English Units (Inch-Pound)		Standard International Units (SI)	
	Description	Abbreviation	Description	Abbreviation
<b>Temperature</b>	Degrees Fahrenheit	F	Degrees Celsius	C
<b>Relative Temperature</b>	Delta Degrees Fahrenheit	DDF	Degrees Kelvin	K
<b>Relative Humidity</b>	Percent	%	Percent	%
<b>Air Flow</b>	Cubic Feet per Minute	CFM	Liters per Second of gas	LPS
<b>CO<sub>2</sub> Concentration</b>	Parts Per Million	PPM	Parts Per Million	PPM
<b>Enthalpy</b>	British Thermal Units per Pound of Air	btu/lb	kiloJoules/kilogram	kJ/kg
<b>Differential Pressure</b>	Inches of Water Column	inw	kiloPascal	kPa

Tables C-1 and C-2 list all network variables associated with the W7750 Controller and the default User Address names.

Table C-1 lists the Configuration Parameters, which are the values stored in the controllers EEPROM memory. Table C-2

lists the Network Variable Inputs and Outputs, which are stored in RAM memory. Tables provides point attributes as follows:

Engineering Units—	This field indicates the point valid range and displayed Engineering Unit. For digital points, the valid states and the corresponding enumerated values are shown.
Default—	The value or state of the point on controller start-up.
Shareable—	The point can be set up for data sharing in Command Multiple Points, Read Multiple Points, or Refer Excel 10 Points as either a data source or a destination.
Mappable—	The point can be converted into a C-Bus point use use by C-Bus devices. A mappable point has a one-to-one relationship with a C-Bus User Address.
Direct Access—	The point is accessible through the Subsystem Points mechanism in XBS.
E-Vision Monitor—	These points are viewable within the E-Vision Controller Monitoring on-line screen. PAR refers to control parameters settable in the Application Selection dialog boxes in E-Vision.

Hardware Config—	These are points that involve controller I/O configuration. Any change to HW Config. points causes the W7750 to perform an application reset; therefore, these points can only be modified off-line.
Manual—	These points are used to set the controller outputs when in manual mode. The W7750 is placed in manual mode through a menu selection in the E-Vision Controller Monitor screen.
Fixable—	These input points can be set to a constant value in the E-Vision Controller Monitor screen.

NOTES:

1. Mapped points can be viewed and changed, *if applicable*, on C-Bus devices such as an XI581, XI582 and XI584 and on an XBS central and E-Vision.
2. All Excel 10 points, mappable and calibration, configuration and internal data sharing points, can be viewed and changed, *as allowed*, via Direct Access (DA) mode in the XBS subsystem menu or via XI584.

**Table C-1. User Addresses For W7750 Configuration Parameters.**

(Configuration Parameters are stored in EEPROM - limited to 10,000 writes. Do NOT use as outputs from Control Strategies, Time Programs, or Switching Tables. If these points are changed more than 10,000 times, irreversible hardware failure results)

**Table C-1. Input/Output Points (Left).**

User Address	NvName	Field Name	Engineering Units: English (Metric) or States plus Range	Digital State or Value of State	Default
CORMode	nciloSelect	CorOnMode	COR_ON_HEAT COR_ON_COLL	0 1	COR_ON_COOL
	nciloSelect	ResistiveIn[0]	DISCHARGE_TEMP_PT3000 OUTDOOR_TEMP_PT3000 RETURN_TEMP_PT3000 DISCHARGE_TEMP_20KNTC RETURN_TEMP_20KNTC UNUSED_RAI	0 1 2 3 4 255	UNUSED_RAI
	nciloSelect	ResistiveIn[1]	DISCHARGE_TEMP_PT3000 OUTDOOR_TEMP_PT3000 RETURN_TEMP_PT3000 DISCHARGE_TEMP_20KNTC RETURN_TEMP_20KNTC UNUSED_RAI	0 1 2 3 4 255	UNUSED_RAI
	nciloSelect	VoltageIn[0]	RTN_HUM_C7600C RETURN_ENTHALPY OD_HUM_C7600C OUTDOOR_ENTHALPY FILTER_STATIC_PRESS_DIFF SPACE_CO2 MONITOR_SENSOR1 RTN_HUM_C7600B OD_HUM_C7600B UNUSED_VAI	0 1 2 3 4 5 6 7 8 255	UNUSED_VAI

Table C-1. Input/Output Points (Right).

E-Vision (EV): Calibrate (C), Monitor (M), Parameter (P), Schematic (S) Share (SH), Map (MA), Direct Access (DA) Hardware Configuration (HW), Manual Configuration (MN), Test (TS)							Comments
EV	SH	MA	DA	HW	MN	TS	
P			X				CorOnMode specifies the mode when the Change Over Relay (COR) is energized.
				X			ResistiveIn [0] specifies which logical sensor is assigned to which physical analog input sensor channel according to the enumerated list that is shown in the Engineering Units/States column. ResistiveIn[0] is the only input available in the W7750A controller.
				X			ResistiveIn [1] specifies which logical sensor is assigned to which physical analog input sensor channel according to the enumerated list that is shown in the Engineering Units/States column. ResistiveIn[0] is the only input available in the W7750A controller.
				X			VoltageIn [0] specifies which logical sensor is assigned to which physical analog input sensor channel according to the enumerated list that is shown in the Engineering Units/States column. (Voltage inputs are not available in the W7750A controller.)

(continued)

Table C-1. Input/Output Points (Left Continued).

User Address	NvName	Field Name	Engineering Units: English (Metric) or States plus Range	Digital State or Value of State	Default
	nciloSelect	VoltageIn[1]	RTN_HUM_C7600C RETURN_ENTHALPY OD_HUM_C7600C OUTDOOR_ENTHALPY FILTER_STATIC_PRESS_DIFF SPACE_CO2 MONITOR_SENSOR1 RTN_HUM_C7600B OD_HUM_C7600B UNUSED_VAI	0 1 2 3 4 5 6 7 8 255	UNUSED_VAI
	nciloSelect	DigitalIn[0]	OCC_SENSOR OCC_TIME_CLOCK PROOF_AIR_FLOW ECON_ENABLE IAQ_OVERRIDE SMOKE_MONITOR DIRTY_FILTER SHUT_DOWN WINDOW_OPEN MONITOR SCHED_MASTER UNUSED_DI	2 3 4 5 6 7 8 9 10 11 12 255	OCC_TIME_CLOCK_IN
	nciloSelect	DigitalIn[1]	OCC_SENSOR OCC_TIME_CLOCK PROOF_AIR_FLOW ECON_ENABLE IAQ_OVERRIDE SMOKE_MONITOR DIRTY_FILTER SHUT_DOWN WINDOW_OPEN MONITOR SCHED_MASTER UNUSED_DI	2 3 4 5 6 7 8 9 10 11 12 255	SHCED_MASTER_IN

Table C-1. Input/Output Points (Right Continued).

E-Vision (EV): Calibrate (C), Monitor (M), Parameter (P), Schematic (S) Share (SH), Map (MA), Direct Access (DA) Hardware Configuration (HW), Manual Configuration (MN), Test (TS)							Comments
EV	SH	MA	DA	HW	MN	TS	
				X			VoltageIn [1] specifies which logical sensor is assigned to which physical analog input sensor channel according to the enumerated list that is shown in the Engineering Units/States column. (Voltage inputs are not available in the W7750A controller.)
				X			DigitalIn[0] specifies which logical switch type is connected to the flexible digital input switch channel according to the enumerated list that is shown in the Engineering Units/States column. DigitalIn[0] and DigitalIn[1] are the only inputs available in the W7750A controller. The controller is configured at the factory with this user address configured to OCC_TIME_CLOCK_IN.
				X			DigitalIn[1] specifies which logical switch type is connected to the flexible digital input switch channel according to the enumerated list that is shown in the Engineering Units/States column. DigitalIn[0] and DigitalIn[1] are the only inputs available in the W7750A controller. The controller is configured at the factory with this user address configured to SCHED_MASTER_IN.

(continued)

Table C-1. Input/Output Points (Left Continued).

User Address	NvName	Field Name	Engineering Units: English (Metric) or States plus Range	Digital State or Value of State	Default
	nciloSelect	DigitalIn[2]	OCC_SENSOR OCC_TIME_CLOCK PROOF_AIR_FLOW ECON_ENABLE IAQ_OVERRIDE SMOKE_MONITOR DIRTY_FILTER SHUT_DOWN WINDOW_OPEN MONITOR SCHED_MASTER UNUSED_DI	2 3 4 5 6 7 8 9 10 11 12 255	UNUSED_DI
	nciloSelect	DigitalOut[1]	COOL_STAGE_1 COOL_STAGE_2 COOL_STAGE_3 COOL_STAGE_4 HEAT_STAGE_1 HEAT_STAGE_2 HEAT_STAGE_3 HEAT_STAGE_4 CHANGE_OVER_RELAY FAN AUX_ECON OCCUPANCY_STATUS ECON_OPEN ECON_CLOSE COOL_OPEN COOL_CLOSE HEAT_OPEN HEAT_CLOSE HEAT_COOL_STAGE_1 HEAT_COOL_STAGE_2 HEAT_COOL_STAGE_3 HEAT_COOL_STAGE_4 FREE1 FREE2 FREE1_PULSE_ON FREE1_PULSE_OFF ECON_PWM HEAT_PWM COOL_PWM UNUSED_OUT	1 2 3 4 5 6 7 8 9 10 11 12 13 14 15 16 17 18 19 20 21 22 25 26 27 28 29 30 31 255	FAN_OUT

Table C-1. Input/Output Points (Right Continued).

E-Vision (EV): Calibrate (C), Monitor (M), Parameter (P), Schematic (S) Share (SH), Map (MA), Direct Access (DA) Hardware Configuration (HW), Manual Configuration (MN), Test (TS)							Comments
EV	SH	MA	DA	HW	MN	TS	
				X			DigitalIn[2] specifies which logical switch type is connected to the flexible digital input switch channel according to the enumerated list that is shown in the Engineering Units/States column. DigitalIn[0] and DigitalIn[1] are the only inputs available in the W7750A controller.
				X			DigitalOut[1] specifies which logical digital output function is assigned to the digital physical output according to the enumerated list that is shown in the Engineering Units/States column. Only DigitalOut[0] through DigitalOut[5] are available in the W7750A model and only staged outputs can be configured. Floating Economizer is allowed in the W7750A model. (No PWM outputs are allowed in the W7750A model.) The controller is configured at the factory with this user address configured to FAN_OUT.

(continued)

Table C-1. Input/Output Points (Left Continued).

User Address	NvName	Field Name	Engineering Units: English (Metric) or States plus Range	Digital State or Value of State	Default
	nciloSelect	DigitalOut[2]	COOL_STAGE_1 COOL_STAGE_2 COOL_STAGE_3 COOL_STAGE_4 HEAT_STAGE_1 HEAT_STAGE_2 HEAT_STAGE_3 HEAT_STAGE_4 CHANGE_OVER_RELAY FAN AUX_ECON OCCUPANCY_STATUS ECON_OPEN ECON_CLOSE COOL_OPEN COOL_CLOSE HEAT_OPEN HEAT_CLOSE HEAT_COOL_STAGE_1 HEAT_COOL_STAGE_2 HEAT_COOL_STAGE_3 HEAT_COOL_STAGE_4 FREE1 FREE2 FREE1_PULSE_ON FREE1_PULSE_OFF ECON_PWM HEAT_PWM COOL_PWM UNUSED_OUT	1 2 3 4 5 6 7 8 9 10 11 12 13 14 15 16 17 18 19 20 21 22 25 26 27 28 29 30 31 255	COOL_STAGE_2

Table C-1. Input/Output Points (Right Continued).

E-Vision (EV): Calibrate (C), Monitor (M), Parameter (P), Schematic (S) Share (SH), Map (MA), Direct Access (DA) Hardware Configuration (HW), Manual Configuration (MN), Test (TS)							Comments
EV	SH	MA	DA	HW	MN	TS	
				X			DigitalOut[2] specifies which logical digital output function is assigned to the digital physical output according to the enumerated list that is shown in the Engineering Units/States column. Only DigitalOut[0] through DigitalOut[5] are available in the W7750A model and only staged outputs can be configured. Floating Economizer is allowed in the W7750A model. (No PWM outputs are allowed in the W7750A model.) The controller is configured at the factory with this user address configured to COOL_STAGE_2.

(continued)

Table C-1. Input/Output Points (Left Continued).

User Address	NvName	Field Name	Engineering Units: English (Metric) or States plus Range	Digital State or Value of State	Default
	nciloSelect	DigitalOut[3]	COOL_STAGE_1 COOL_STAGE_2 COOL_STAGE_3 COOL_STAGE_4 HEAT_STAGE_1 HEAT_STAGE_2 HEAT_STAGE_3 HEAT_STAGE_4 CHANGE_OVER_RELAY FAN AUX_ECON OCCUPANCY_STATUS ECON_OPEN ECON_CLOSE COOL_OPEN COOL_CLOSE HEAT_OPEN HEAT_CLOSE HEAT_COOL_STAGE_1 HEAT_COOL_STAGE_2 HEAT_COOL_STAGE_3 HEAT_COOL_STAGE_4 FREE1 FREE2 FREE1_PULSE_ON FREE1_PULSE_OFF ECON_PWM HEAT_PWM COOL_PWM UNUSED_OUT	1 2 3 4 5 6 7 8 9 10 11 12 13 14 15 16 17 18 19 20 21 22 25 26 27 28 29 30 31 255	COOL_STAGE_1

Table C-1. Input/Output Points (Right Continued).

E-Vision (EV): Calibrate (C), Monitor (M), Parameter (P), Schematic (S) Share (SH), Map (MA), Direct Access (DA) Hardware Configuration (HW), Manual Configuration (MN), Test (TS)							Comments
EV	SH	MA	DA	HW	MN	TS	
				X			DigitalOut[3] specifies which logical digital output function is assigned to the digital physical output according to the enumerated list that is shown in the Engineering Units/States column. Only DigitalOut[0] through DigitalOut[5] are available in the W7750A model and only staged outputs can be configured. Floating Economizer is allowed in the W7750A model. (No PWM outputs are allowed in the W7750A model.) The controller is configured at the factory with this user address configured to COOL_STAGE_1.

(continued)

Table C-1. Input/Output Points (Left Continued).

User Address	NvName	Field Name	Engineering Units: English (Metric) or States plus Range	Digital State or Value of State	Default
	nciloSelect	DigitalOut[4]	COOL_STAGE_1 COOL_STAGE_2 COOL_STAGE_3 COOL_STAGE_4 HEAT_STAGE_1 HEAT_STAGE_2 HEAT_STAGE_3 HEAT_STAGE_4 CHANGE_OVER_RELAY FAN AUX_ECON OCCUPANCY_STATUS ECON_OPEN ECON_CLOSE COOL_OPEN COOL_CLOSE HEAT_OPEN HEAT_CLOSE HEAT_COOL_STAGE_1 HEAT_COOL_STAGE_2 HEAT_COOL_STAGE_3 HEAT_COOL_STAGE_4 FREE1 FREE2 FREE1_PULSE_ON FREE1_PULSE_OFF ECON_PWM HEAT_PWM COOL_PWM UNUSED_OUT	1 2 3 4 5 6 7 8 9 10 11 12 13 14 15 16 17 18 19 20 21 22 25 26 27 28 29 30 31 255	HEAT_STAGE_2

Table C-1. Input/Output Points (Right Continued).

E-Vision (EV): Calibrate (C), Monitor (M), Parameter (P), Schematic (S) Share (SH), Map (MA), Direct Access (DA) Hardware Configuration (HW), Manual Configuration (MN), Test (TS)							Comments
EV	SH	MA	DA	HW	MN	TS	
				X			DigitalOut[4] specifies which logical digital output function is assigned to the digital physical output according to the enumerated list that is shown in the Engineering Units/States column. Only DigitalOut[0] through DigitalOut[5] are available in the W7750A model and only staged outputs can be configured. Floating Economizer is allowed in the W7750A model. (No PWM outputs are allowed in the W7750A model.) The controller is configured at the factory with this HEAT_STAGE_2.

(continued)

Table C-1. Input/Output Points (Left Continued).

User Address	NvName	Field Name	Engineering Units: English (Metric) or States plus Range	Digital State or Value of State	Default
	nciloSelect	DigitalOut[5]	COOL_STAGE_1 COOL_STAGE_2 COOL_STAGE_3 COOL_STAGE_4 HEAT_STAGE_1 HEAT_STAGE_2 HEAT_STAGE_3 HEAT_STAGE_4 CHANGE_OVER_RELAY FAN AUX_ECON OCCUPANCY_STATUS ECON_OPEN ECON_CLOSE COOL_OPEN COOL_CLOSE HEAT_OPEN HEAT_CLOSE HEAT_COOL_STAGE_1 HEAT_COOL_STAGE_2 HEAT_COOL_STAGE_3 HEAT_COOL_STAGE_4 FREE1 FREE2 FREE1_PULSE_ON FREE1_PULSE_OFF ECON_PWM HEAT_PWM COOL_PWM UNUSED_OUT	1 2 3 4 5 6 7 8 9 10 11 12 13 14 15 16 17 18 19 20 21 22 25 26 27 28 29 30 31 255	HEAT_STAGE_1

Table C-1. Input/Output Points (Right Continued).

E-Vision (EV): Calibrate (C), Monitor (M), Parameter (P), Schematic (S) Share (SH), Map (MA), Direct Access (DA) Hardware Configuration (HW), Manual Configuration (MN), Test (TS)							Comments
EV	SH	MA	DA	HW	MN	TS	
				X			DigitalOut[5] specifies which logical digital output function is assigned to the digital physical output according to the enumerated list that is shown in the Engineering Units/States column. Only DigitalOut[0] through DigitalOut[5] are available in the W7750A model and only staged outputs can be configured. Floating Economizer is allowed in the W7750A model. (No PWM outputs are allowed in the W7750A model.) The controller is configured at the factory with this HEAT_STAGE_1.

(continued)

Table C-1. Input/Output Points (Left Continued).

User Address	NvName	Field Name	Engineering Units: English (Metric) or States plus Range	Digital State or Value of State	Default
	nciloSelect	DigitalOut[6]	COOL_STAGE_1 COOL_STAGE_2 COOL_STAGE_3 COOL_STAGE_4 HEAT_STAGE_1 HEAT_STAGE_2 HEAT_STAGE_3 HEAT_STAGE_4 CHANGE_OVER_RELAY FAN AUX_ECON OCCUPANCY_STATUS ECON_OPEN ECON_CLOSE COOL_OPEN COOL_CLOSE HEAT_OPEN HEAT_CLOSE HEAT_COOL_STAGE_1 HEAT_COOL_STAGE_2 HEAT_COOL_STAGE_3 HEAT_COOL_STAGE_4 FREE1 FREE2 FREE1_PULSE_ON FREE1_PULSE_OFF ECON_PWM HEAT_PWM COOL_PWM UNUSED_OUT	1 2 3 4 5 6 7 8 9 10 11 12 13 14 15 16 17 18 19 20 21 22 25 26 27 28 29 30 31 255	UNUSED

Table C-1. Input/Output Points (Right Continued).

E-Vision (EV): Calibrate (C), Monitor (M), Parameter (P), Schematic (S) Share (SH), Map (MA), Direct Access (DA) Hardware Configuration (HW), Manual Configuration (MN), Test (TS)							Comments
EV	SH	MA	DA	HW	MN	TS	
				X			DigitalOut[6] specifies which logical digital output function is assigned to the digital physical output according to the enumerated list that is shown in the Engineering Units/States column. Only DigitalOut[0] through DigitalOut[5] are available in the W7750A model and only staged outputs can be configured. (DigitalOut[6] is not available on the W7750A.) The controller is configured at the factory with this UNUSED.

(continued)

Table C-1. Input/Output Points (Left Continued).

User Address	NvName	Field Name	Engineering Units: English (Metric) or States plus Range	Digital State or Value of State	Default
	nciloSelect	DigitalOut[7]	COOL_STAGE_1 COOL_STAGE_2 COOL_STAGE_3 COOL_STAGE_4 HEAT_STAGE_1 HEAT_STAGE_2 HEAT_STAGE_3 HEAT_STAGE_4 CHANGE_OVER_RELAY FAN AUX_ECON OCCUPANCY_STATUS ECON_OPEN ECON_CLOSE COOL_OPEN COOL_CLOSE HEAT_OPEN HEAT_CLOSE HEAT_COOL_STAGE_1 HEAT_COOL_STAGE_2 HEAT_COOL_STAGE_3 HEAT_COOL_STAGE_4 FREE1 FREE2 FREE1_PULSE_ON FREE1_PULSE_OFF ECON_PWM HEAT_PWM COOL_PWM UNUSED_OUT	1 2 3 4 5 6 7 8 9 10 11 12 13 14 15 16 17 18 19 20 21 22 25 26 27 28 29 30 31 255	UNUSED
	nciloSelect	HtPump	CONV HP	0 1	CONV
	nciloSelect	FiftySixtyHz	SIXTY FIFTY	0 1	SIXTY

Table C-1. Input/Output Points (Right Continued).

E-Vision (EV): Calibrate (C), Monitor (M), Parameter (P), Schematic (S) Share (SH), Map (MA), Direct Access (DA) Hardware Configuration (HW), Manual Configuration (MN), Test (TS)							Comments
EV	SH	MA	DA	HW	MN	TS	
				X			DigitalOut[7] specifies which logical digital output function is assigned to the digital physical output according to the enumerated list that is shown in the Engineering Units/States column. Only DigitalOut[0] through DigitalOut[5] are available in the W7750A model and only staged outputs can be configured. (DigitalOut[7] is not available on the W7750A.) The controller is configured at the factory with this UNUSED.
P			X				HtPump specifies the type of equipment being controlled. When HtPump is 0 (CONV), the node is controlling conventional gas or electric heat. When HtPump is 1 (HP), the node is controlling a heat pump.
P			X				FiftySixtyHz specifies the frequency of the main power input for the controller. Correctly selecting the FiftySixtyHz decreases the noise picked up by analog switch wiring from the power mains. When FiftySixtyHz is 0 (SIXTY is the default), the mains frequency is sixty Hz and when FiftySixtyHz is 1 (FIFTY), the mains frequency is fifty Hz.

(continued)

Table C-1. Input/Output Points (Left Continued).

User Address	NvName	Field Name	Engineering Units: English (Metric) or States plus Range	Digital State or Value of State	Default
	nciloSelect	SpaceSensorType	T7770	0	T7770
RmtStptPot	nvoIO	siSetPointTempS7	Degrees F -9 to 85 Degrees C (-23 to 29)		SI_INVALID
RmTempSensr	nvoIO	siSpaceTempS7	Degrees F 40 to 100 Degrees C (4 to 38)		SI_INVALID
DaTempSensr	nvoIO	siDischargeTempS7	Degrees F 30 to 122 Degrees C (-1 to 50)		SI_INVALID
RaTempSensr	nvoIO	siReturnTempS7	Degrees F 30 to 122 Degrees C (-1 to 50)		SI_INVALID
RaHumSensr	nvoIO	ReturnHumidity	Percentage 10 to 90		SI_INVALID
RaEnthSensr	nvoIO	siReturnEnthalpyS7	mA 4 to 20		SI_INVALID
OaTempSensr	nvoIO	siOutdoorTempS7	Degrees F -40 to 122 Degrees C (-40 to 50)		SI_INVALID
OaHumSensr	nvoIO	OutdoorHumidity	Percentage 10 to 90		SI_INVALID
OaEnthSensr	nvoIO	siOutdoorEnthalpyS7	mA 4 to 20		SI_INVALID
FiltrPressSensr	nvoIO	siFilterPressureS10	inw (kPa) 0 to 5 (0 to 1.25)		SI_INVALID
CO2Sensr	nvoIO	siSpaceCo2S0	PPM 150 to 2000		SI_INVALID
MonitorSensr	nvoIO	siMonitorS10	volts 1 to 10		SI_INVALID

Table C-1. Input/Output Points (Right Continued).

E-Vision (EV): Calibrate (C), Monitor (M), Parameter (P), Schematic (S) Share (SH), Map (MA), Direct Access (DA) Hardware Configuration (HW), Manual Configuration (MN), Test (TS)							Comments
EV	SH	MA	DA	HW	MN	TS	
				X			SpaceSensorType specifies the type of space temperature sensor connected to the node. When SpaceSensorType is 0, a T7770 sensor is connected to the sensor terminals. No other options are currently valid.
M, S		X	X		X		SetPointTemp is the wall module setpoint temperature. When nciConfig.SetPointTemp is ABSOLUTE_COOL or ABSOLUTE_MIDDLE, the reported value is the absolute setpoint temperature. When Config.SetPntKnob is OFFSET, the reported value is the offset (from the current active TempSetPts) temperature. If the input is not configured or has failed, the value is SI_INVALID.
M, S							SpaceTemp is the measured space temperature. If the sensor is not configured or has failed, the value is SI_INVALID. NOTE: The reported temperatures includes the offset correction provided by Config.ResistiveOffsetCal.
							DischargeTemp is the measured discharge air temperature. If the sensor is not configured or has failed, the value is SI_INVALID. Refer to the note on SpaceTemp.
							ReturnTemp is the measured return air temperature. If the sensor is not configured or has failed, the value is SI_INVALID. Refer to the note on SpaceTemp.
							ReturnHumidity is the measured return air humidity. If the sensor is not configured or has failed, the value is UB_INVALID. NOTE: The reported temperatures includes the offset correction provided by Config.VoltageOffsetCal.
							ReturnEnthalpy is the measured return air enthalpy. If the sensor is not configured or has failed, the value is SI_INVALID. Since the C7400 reports comfort due to enthalpy (btu/lb) in milliamps, enthalpy is also reported in milliamps. Refer to the NOTE on ReturnHumidity.
M, S							OutdoorTemp is the measured outdoor air temperature. If the sensor is not configured or has failed, the value is SI_INVALID. Refer to the NOTE on ReturnHumidity.
M, S							OutdoorHumidity is the measured outdoor air humidity. If the sensor is not configured or has failed, the value is UB_INVALID. Refer to the NOTE on ReturnHumidity.
M, S							OutdoorEnthalpy is the measured outdoor air enthalpy. If the sensor is not configured or has failed, the value is SI_INVALID. Since the C7400 reports comfort due to enthalpy (btu/lb) in milliamps, enthalpy is also reported in milliamps. Refer to the NOTE on ReturnHumidity.
							FilterPressure is the measured differential pressure across the return air filter. If the sensor is not configured or has failed, the value is the SI_INVALID. Refer to the NOTE on ReturnHumidity.
							SpaceCo2 is the measured CO2 in the conditioned air space. If the sensor is not configured or has failed, the value is SI_INVALID. Refer to the NOTE on ReturnHumidity.
							Monitor is the voltage applied at the monitor inputs terminals. If the sensor is not configured or has failed, the value is SI_INVALID. Refer to the NOTE on ReturnHumidity.

(continued)

Table C-1. Input/Output Points (Left Continued).

User Address	NvName	Field Name	Engineering Units: English (Metric) or States plus Range	Digital State or Value of State	Default
StatusDO1	nvoIO	ubOut Byte Offset = 24 Bit Offset = 0 (DigitalOut1)	FALSE TRUE	0 1	FALSE
StatusDO2	nvoIO	ubOut Byte Offset = 24 Bit Offset = 1 (DigitalOut2)	FALSE TRUE	0 1	FALSE
StatusDO3	nvoIO	ubOut Byte Offset = 24 Bit Offset = 2 (DigitalOut3)	FALSE TRUE	0 1	FALSE
StatusDO4	nvoIO	ubOut Byte Offset = 24 Bit Offset = 3 (DigitalOut4)	FALSE TRUE	0 1	FALSE
StatusDO5	nvoIO	ubOut Byte Offset = 24 Bit Offset = 4 (DigitalOut5)	FALSE TRUE	0 1	FALSE
StatusDO6	nvoIO	ubOut Byte Offset = 24 Bit Offset = 5 (DigitalOut6)	FALSE TRUE	0 1	FALSE
StatusDO7	nvoIO	ubOut Byte Offset = 24 Bit Offset = 6 (DigitalOut7)	FALSE TRUE	0 1	FALSE
StatusDO8	nvoIO	ubOut Byte Offset = 24 Bit Offset = 7 (DigitalOut8)	FALSE TRUE	0 1	FALSE
StatusDI1	nvoIO	ubDigitalIn Byte Offset = 25 Bit Offset = 7 (DigitalIn1)	FALSE TRUE	0 1	FALSE
StatusDI2	nvoIO	ubDigitalIn Byte Offset = 25 Bit Offset = 6 (DigitalIn2)	FALSE TRUE	0 1	FALSE
StatusDI3	nvoIO	ubDigitalIn Byte Offset = 25 Bit Offset = 5 (DigitalIn3)	FALSE TRUE	0 1	FALSE
StatusDI4	nvoIO	ubDigitalIn Byte Offset = 25 Bit Offset = 4 (DigitalIn4)	FALSE TRUE	0 1	FALSE

Table C-1. Input/Output Points (Right Continued).

E-Vision (EV): Calibrate (C), Monitor (M), Parameter (P), Schematic (S) Share (SH), Map (MA), Direct Access (DA) Hardware Configuration (HW), Manual Configuration (MN), Test (TS)							Comments
EV	SH	MA	DA	HW	MN	TS	
							DigitalOut1 is a byte with a bit for every physical digital output. On is a 1 (TRUE) and off is a 0 (FALSE).
							DigitalOut2 is a byte with a bit for every physical digital output. On is a 1 (TRUE) and off is a 0 (FALSE).
							DigitalOut3 is a byte with a bit for every physical digital output. On is a 1 (TRUE) and off is a 0 (FALSE).
							DigitalOut4 is a byte with a bit for every physical digital output. On is a 1 (TRUE) and off is a 0 (FALSE).
							DigitalOut5 is a byte with a bit for every physical digital output. On is a 1 (TRUE) and off is a 0 (FALSE).
							DigitalOut6 is a byte with a bit for every physical digital output. On is a 1 (TRUE) and off is a 0 (FALSE).
							DigitalOut7 is a byte with a bit for every physical digital output. On is a 1 (TRUE) and off is a 0 (FALSE).
							DigitalOut8 is a byte with a bit for every physical digital output. On is a 1 (TRUE) and off is a 0 (FALSE).
							DigitalIn1 is a byte with a bit for every physical digital input. If the input is shorted to ground, the bit is a zero or FALSE. If the input is open, the bit is one or TRUE.
							DigitalIn2 is a byte with a bit for every physical digital input. If the input is shorted to ground, the bit is a zero or FALSE. If the input is open, the bit is one or TRUE.
							DigitalIn3 is a byte with a bit for every physical digital input. If the input is shorted to ground, the bit is a zero or FALSE. If the input is open, the bit is one or TRUE.
							DigitalIn4 is a byte with a bit for every physical digital input. If the input is shorted to ground, the bit is a zero or FALSE. If the input is open, the bit is one or TRUE.

(continued)

Table C-1. Input/Output Points (Left Continued).

User Address	NvName	Field Name	Engineering Units: English (Metric) or States plus Range	Digital State or Value of State	Default
Model	nvoIO	ubDigitalIn Byte Offset = 25 Bit Offset = 3 (ExtenedModelln)	FALSE TRUE	0 1	FALSE
OvrdsW	nvoIO	OverRide	FALSE TRUE	0 1	FALSE
OccSensr	nvoIO	OccupancySensor	FALSE TRUE	0 1	FALSE
TimeClkSw	nvoIO	OccTimeClock	FALSE TRUE	0 1	FALSE
StatusAirFlow	nvoIO	ProofAirFlow	FALSE TRUE	0 1	FALSE
EconEnSw	nvoIO	EconEnableIn	FALSE TRUE	0 1	FALSE
IaqOvrSw	nvoIO	IaqOverRide	FALSE TRUE	0 1	FALSE
SmokeMonSw	nvoIO	SmokeMonitor	FALSE TRUE	0 1	FALSE
DrtyFilterSw	nvoIO	DirtyFilter	FALSE TRUE	0 1	FALSE
ShutDownSw	nvoIO	ShutDown	FALSE TRUE	0 1	FALSE
WindowSw	nvoIO	WindowOpen	FALSE TRUE	0 1	FALSE
MonitorSw	nvoIO	MonSwitch	FALSE TRUE	0 1	FALSE
ModelSw	nvoIO	Model	FALSE TRUE	0 1	FALSE
	nvoIO	SchedMaster	FALSE TRUE	0 1	FALSE

Table C-1. Input/Output Points (Right Continued).

E-Vision (EV): Calibrate (C), Monitor (M), Parameter (P), Schematic (S) Share (SH), Map (MA), Direct Access (DA) Hardware Configuration (HW), Manual Configuration (MN), Test (TS)							Comments
EV	SH	MA	DA	HW	MN	TS	
			X				ExtenedModelIn is a byte with a bit for every physical digital input. If the input is shorted to ground, the bit is a zero or FALSE. If the input is open, the bit is one or TRUE.
							OverRide indicates the status of the wall module override pushbutton. It is 1 (TRUE) if the button is pressed, and is 0 (FALSE) if it isn't pressed.
M, S							OccupancySensor is the state of the digital input configured and wired to the local occupancy sensor. 1 means that occupancy is being sensed (input circuit shorted) and 0 means that no occupancy is being sensed (input circuit open).
M, S							OccTimeClock is the state of the digital input configured and wired to a time clock. 1 (input shorted) means that the scheduled occupancy is OC_OCCUPIED, and 0 (input open circuited) means that the scheduled occupancy is OC_UNOCCUPIED.
							ProofAirFlow is the state of the digital input configured and wired to the proof of air flow switch. 1 (input shorted) means that air flow is detected and 0 (input open circuited) means that air flow is not detected.
M, S							EconEnableIn is the state of the digital input configured and wired to the outdoor air sensor that determines the suitability of outdoor air for free cooling. 1 (input shorted) means that the outdoor air is suitable for cooling, and 0 (input open) means that the outdoor air is not suitable for cooling.
M, S							IaqOverRide is the state of the digital input configured and wired to the indoor air quality sensor. 1 (input shorted) means that the indoor air quality is poor, and 0 (input open) means that the indoor air quality is acceptable. This input is used to cause the economizer to open to a predetermined position when poor indoor air quality is detected.
M, S							SmokeMonitor is the state of the digital input configured and wired to the indoor smoke sensor. 1 (input shorted) means that smoke is detected, and 0 (input open) means that no smoke is detected.
M, S							DirtyFilter is the state of the digital input configured and wired to the dirty filter sensor. 1 (input shorted) means that filter is dirty, and 0 (input open) means that the filter is not dirty.
							ShutDown is the state of the digital input configured and wired to the shut down switch. 1 (input shorted) means that equipment should be shut down, and 0 (input open) means that the equipment should be running.
M, S							WindowOpen is the state of the digital input configured and wired to a window open sensor switch. 1 (input open circuit) means that the window is open, and 0 (input shorted) means that the window is closed.
							MonSwitch is the state of the digital input configured and wired to a general purpose monitor switch. 1 (input shorted) means that switch is closed, and 0 (input open) means that the switch is open.
			X				Model indicates the Model of the node. One of the digital inputs is connected to a printed wiring board trace to let the embedded software know what kind of hardware is present. If Model is 1 (input held high), the hardware is the W7750B Model. If Model is 0 (input shorted to ground), the hardware is the W7750A Model.
M			X				If ScheduleMaster is 1 (input shorted), the node is the schedule master and the locally connected time clock will be sent via TimeClk to other nodes on the network. If ScheduleMaster is 0, (input open), the node is not a schedule master and nvoTimeClk will not be sent on the network even if the time clock input is configured. If the ScheduleMaster input is not configured by Select, TimeClk reports the state of the locally connected time clock.

Table C-2. Control Parameters (Left).

User Address	NvName	Field Name	Engineering Units: English (Metric) or States plus Range	Digital State or Value of State	Default
DaTempLoLim	nciAux1SetPt	siLowLimitDischAirTempS7	Degrees F 0 to 60 Degrees C (-1 to 16)		45
DaTempHiLim	nciAux1SetPt	siMaxDisAirTempHeatS7	Degrees F 65 to 135 (18 to 57)		100
DlcBumpTemp	nciAux1SetPt	siDlcBumpTempS7	Degrees F 0 to +10 (-18 to -12)		3
OaTempHtLkOut	nciAux1SetPt	ubOdHtLockOutTempS0	Degrees F 0 to 90 (-18 to 32)		70
MaxHtRamp	nciAux1SetPt	ubMaxHtRampS0	Degrees F/Hr 0 to 20 Degrees C/Hr (0 to 11)		8
MinHtRamp	nciAux1SetPt	ubMinHtRampS0	Degrees F/Hr 0 to 20 Degrees C/Hr (0 to 11)		3
OaTempMaxHtRp	nciAux1SetPt	ubOdTempMaxHtRampS0	Degrees F 0 to 100 Degrees C (-18 to 38)		40
OaTempMinHtRp	nciAux1SetPt	ubOdTempMinHtRampS0	Degrees F 0 to 100 Degrees C (-18 to 38)		0

Table C-2. Control Parameters (Right).

E-Vision (EV): Calibrate (C), Monitor (M), Parameter (P), Schematic (S) Share (SH), Map (MA), Direct Access (DA) Hardware Configuration (HW), Manual Configuration (MN), Test (TS)							Comments
EV	SH	MA	DA	HW	MN	TS	
P		X	X				When the discharge air temperature falls below LowLimitDischAirTemp, the outdoor air dampers are closed to a position that corrects the low temperature problem. If mechanical cooling is active when the discharge air falls below LowLimitDischAirTemp, the mechanical cooling cycles off after the minimum run times are obeyed to allow the dampers to return open and provide free cooling.
P		X	X				When the mode is HEAT, and the CascadeControl is enabled, the discharge air temperature is controlled to a value not to exceed MaxDisAirTempHeat.
P		X	X				When DlcShed is not 0 then the setpoint is shifted by DlcBumpTemp in the energy saving direction. When DlcShed changes from 1 to 0, the setpoint shift ramps back to 0 over a 30 minute interval.
P		X	X				When the outdoor air temperature is greater than OdHtLockOutTemp, the heating is disabled.
P		X	X				MaxHtRamp is the maximum heat recovery ramp rate in degrees F per hour. This value is used to control the adaptive recovery ramp rate during the HEAT recovery period. The setpoint is changed at a rate in degrees F per hour depending on the outdoor air temperature and the MinHtRamp, OdTempMaxHtRamp, and OdTempMinHtRamp parameters. If there is no outdoor air temperature sensor available, then ubMinHtRamp is used as the recovery rate. NOTE: Recovery ramping applies between scheduled heating or cooling setpoint changes from OC_UNOCCUPIED to OC_STANDBY, OC_UNOCCUPIED to OC_OCCUPIED, and OC_STANDBY to OC_OCCUPIED. Scheduled setpoint changes from OC_OCCUPIED to OC_UNOCCUPIED or OC_OCCUPIED to OC_STANDBY do not use a ramped setpoint but instead use a step change in setpoint. Recovery ramps begin before the next scheduled occupancy time and are ramped from the setpoint for the existing scheduled occupancy state to the setpoint for the next occupancy state.
P		X	X				MinHtRamp is the minimum heat recovery ramp rate in degrees F per hour. This value is used to control the adaptive recovery ramp rate during the HEAT recovery period. The setpoint is changed at a rate in degrees F per hour depending on the outdoor air temperature and the MaxHtRamp, OdTempMaxHtRamp, and OdTempMinHtRamp parameters. If there is no outdoor air temperature sensor available, then MinHtRamp is used as the recovery rate. Refer to the NOTE in the comments column for MaxHtRamp for the conditions that recovery ramping applies to.
P		X	X				OdTempMaxHtRamp is the maximum outdoor air temperature parameter that is used to calculate the heat recovery ramp rate setpoint. This value is used to control the adaptive recovery ramp rate during the HEAT recovery period. The setpoint is changed at a rate in degrees F per hour depending on the outdoor air temperature and the MaxHtRamp, MinHtRamp, and OdTempMinHtRamp parameters. If there is no outdoor air temperature sensor available, then MinHtRamp is used as the recovery rate. Refer to the NOTE in the comments column for MaxHtRamp for what conditions that recovery ramping applies to.
P		X	X				OdTempMinHtRamp is the minimum outdoor air temperature parameter that is used to calculate the heat recovery ramp rate setpoint. This value is used to control the adaptive recovery ramp rate during the HEAT recovery period. The setpoint is changed at a rate in degrees F per hour depending on the outdoor air temperature and the MaxHtRamp, MinHtRamp, and OdTempMaxHtRamp parameters. If there is no outdoor air temperature sensor available, then MinHtRamp is used as the recovery rate. Refer to the NOTE in the comments column for MaxHtRamp for what conditions that recovery ramping applies to.

(continued)

Table C-2. Control Parameters (Left Continued).

User Address	NvName	Field Name	Engineering Units: English (Metric) or States plus Range	Digital State or Value of State	Default
OaTempCILkOut	nciAux1SetPt	ubOdCILkOutTempS0	Degrees F 0 to 90 (-18 to 32)		50
MaxCIRamp	nciAux1SetPt	ubMaxCIRampS0	Degrees F/Hr 0 to 20 Degrees C/Hr (0 to 11)		6
MinCIRamp	nciAux1SetPt	ubMinCIRampS0	Degrees F/Hr 0 to 20 Degrees C/Hr (0 to 11)		2
OaTempMaxCIRp	nciAux1SetPt	ubOdTempMaxCIRampS0	Degrees F 0 to 100 Degrees C (-18 to 38)		70
OaTempMinCIRp	nciAux1SetPt	ubOdTempMinCIRampS0	Degrees F 0 to 100 Degrees C (-18 to 38)		90
OaEconEnTemp	nciAux1SetPt	ubOdEconEnableTempS0	Degrees F 0 to 90 Degrees C (-18 to 32)		70
DiffEconEnTemp	nciAux1SetPt	ubDiffEconEnableTempS0	Degrees F 0 to 90 (-18 to 32)		4
OaEnthEn	nciAux1SetPt	ubOdEnthalpyEnableS2	btu/lb 0 to 65		25
EconMinPos	nciAux1SetPt	ubEconMinPosS0	Percentage 0 to 100		0
EconIAQPos	nciAux1SetPt	ubEconIaqPosS0	Percentage 0 to 100		80

Table C-2. Control Parameters (Right Continued).

E-Vision (EV): Calibrate (C), Monitor (M), Parameter (P), Schematic (S) Share (SH), Map (MA), Direct Access (DA) Hardware Configuration (HW), Manual Configuration (MN), Test (TS)							Comments
EV	SH	MA	DA	HW	MN	TS	
P		X	X				When the outdoor air temperature is less than OdClLockOutTemp, the cooling is disabled.
P		X	X				MaxClRamp is the maximum cool recovery ramp rate in degrees F per hour. This value is used to control the adaptive recovery ramp rate during the COOL recovery period. The setpoint is changed at a rate in degrees F per hour depending on the outdoor air temperature and the MinClRamp, OdTempMaxClRamp, and OdTempMinClRamp parameters. If there is no outdoor air temperature sensor available, then MinClRamp is used as the recovery rate. Refer to the NOTE in the comments column for MaxHtRamp for the conditions that recovery ramping applies to.
P		X	X				MinClRamp is the minimum cool recovery ramp rate in degrees F per hour. This value is used to control the adaptive recovery ramp rate during the COOL recovery period. The setpoint is changed at a rate in degrees F per hour depending on the outdoor air temperature and the MaxClRamp, OdTempMaxClRamp, and OdTempMinClRamp parameters. If there is no outdoor air temperature sensor available, then MinClRamp is used as the recovery rate. Refer to the NOTE in the comments column for MaxHtRamp for the conditions that recovery ramping applies to.
P		X	X				OdTempMaxClRamp is the maximum outdoor air temperature parameter that is used to calculate the cool recovery ramp rate setpoint. This value is used to control the adaptive recovery ramp rate during the COOL recovery period. The setpoint is changed at a rate in degrees F per hour depending on the outdoor air temperature and the MaxClRamp, MinClRamp, and OdTempMinClRamp parameters. If there is no outdoor air temperature sensor available, then MinClRamp is used as the recovery rate. Refer to the NOTE in the comments column for MaxHtRamp for the conditions that recovery ramping applies to.
P		X	X				OdTempMinClRamp is the minimum outdoor air temperature parameter that is used to calculate the cool recovery ramp rate setpoint. This value is used to control the adaptive recovery ramp rate during the COOL recovery period. The setpoint is changed at a rate in degrees F per hour depending on the outdoor air temperature and the MaxClRamp, MinClRamp, and OdTempMaxClRamp parameters. If there is no outdoor air temperature sensor available, then MinClRamp is used as the recovery rate. Refer to the NOTE in the comments column for MaxHtRamp for the conditions that recovery ramping applies to.
P		X	X				If Config.EconEnable is OD_TEMP, and the outdoor temperature is less than OdEconEnableTemp, then outdoor air is judged suitable to augment mechanical cooling. If Config.EconEnable is SINGLE_ENTH and outdoor temperature is less than ubOdEconEnableTemp (high limit), then outdoor air may be judged suitable to augment mechanical cooling depending on the relationship between calculated outdoor enthalpy and OdEnthalpyEnable.
P		X	X				If Config.EconEnable is DIFF_TEMP, and return air temperature minus outdoor air temperature is greater than DiffEconEnableTemp, then outdoor air is judged suitable to augment mechanical cooling.
P		X	X				If Config.EconEnable is SINGLE_ENTH, and calculated outdoor enthalpy is less than OdEnthalpyEnable, and outdoor temperature is less than OdEconEnableTemp, then outdoor air is judged suitable to augment mechanical cooling.
P		X	X				The minimum allowed position of the economizer damper for HEAT and COOL is EconMinPos.
P		X	X				The control overrides the economizer damper to EconIaqPos when poor indoor air quality is detected.

(continued)

Table C-2. Control Parameters (Left Continued).

User Address	NvName	Field Name	Engineering Units: English (Metric) or States plus Range	Digital State or Value of State	Default
IAQSetpt	nciAux1SetPt	siCO2laqLimitS0	PPM 0 to 2000		800
PwmPeriod	nciAux1SetPt	siPwmPeriodS4	Seconds 0 to 2047		100
PwmZeroScale	nciAux1SetPt	siPwm0pcntS4	Seconds 0 to 2047		1
PwmFullScale	nciAux1SetPt	siPwm100pcntS4	Seconds 0 to 2047		99
BypTime	nciAux2SetPt	uiBypassTime	minutes 0 to 1080		180
FiltrPressStPt	nciAux2SetPt	ubFilterPressStPtS5	inw (kPa) 0 to 5 (0 to 1.25)		0.5
StptKnobLowLim	nciAux2SetPt	siLowStPtS7	Degrees F -9 to 90 Degrees C (-23 to 32)		55
StptKnobHiLim	nciAux2SetPt	siHighStPtS7	Degrees F -9 to 90 Degrees C (-23 to 23)		85
GainCoolProp	nciAux2SetPt	ubKpCoolS2	Degrees F 2 to 30 (1 to 30)		5
GainHeatProp	nciAux2SetPt	ubKpHeatS2	Degrees F 2 to 30 (2 to 17)		5
GainCoolInt	nciAux2SetPt	siKiCoolS0	Seconds 0 to 5000		2050
GainHeatInt	nciAux2SetPt	siKiHeatS0	Seconds 0 to 5000		2050
GainCoolDer	nciAux2SetPt	siKdCoolS0	Seconds 0 to 9000		0
GainHeatDer	nciAux2SetPt	siKdHeatS0	Seconds 0 to 9000		0

Table C-2. Control Parameters (Right Continued).

E-Vision (EV): Calibrate (C), Monitor (M), Parameter (P), Schematic (S) Share (SH), Map (MA), Direct Access (DA) Hardware Configuration (HW), Manual Configuration (MN), Test (TS)							Comments
EV	SH	MA	DA	HW	MN	TS	
P		X	X				When an analog CO <sub>2</sub> sensor is configured and the sensed CO <sub>2</sub> is greater than CO2IaqLimit, then poor indoor air quality is detected and Data1.OverRide is set to 1. When the sensed CO <sub>2</sub> is less than CO2IaqLimit, then the indoor air quality is considered acceptable and Data1.IaqOverRide is set to 0. oData1.IaqOverRide is used to set the economizer damper to Aux1SetPt. EconIaqPos and to possibly turn on the heat according to the state of Config.IaqUseHeat.
P		X	X				When pulse width modulation is used, the period of one pulse width modulation cycle is PwmPeriod seconds. The smallest resolution is 0.1 seconds.
P		X	X				When pulse width modulation is used, the period of a pulse for zero percent output (damper or valve at closed position) is siPwm0pcntS4 seconds. The smallest resolution is 0.1 seconds.
P		X	X				When pulse width modulation is used, the period of a pulse for full scale output (damper or valve at open position) is Pwm100pcnt seconds. The smallest resolution is 0.1 seconds.
P		X	X				uiBypassTime is the time between the pressing of the over ride button at the wall module (or initiating OC_BYPASS via ManOcc) and the return to the original occupancy state. When the bypass state has been activated, the bypass timer is set to BypassTime.
P		X	X				If a filter pressure sensor is configured by IoSelect and the filter pressure reported in Data1.FilterPressure exceeds FilterPressStPt, then a DIRTY_FILTER alarm is generated and Data1.DirtyFilter is set to 1.
P		X	X				LowStPt is the lowest value reported for the setpoint knob. Dependent on the configuration of the setpoint knob (see Config.SetPntKnob) this setting is either absolute [degree Fahrenheit (50 to 90)] in case of absolute setpoint knob configuration or relative [delta degree Fahrenheit (-9 to +9)] in case of relative setpoint knob configuration.
P		X	X				HighStPt is the highest value reported for the setpoint knob. Dependent on the configuration of the setpoint knob (see Config.SetPntKnob) this setting is either absolute [degree Fahrenheit (50 to 90)] in case of absolute setpoint knob configuration or relative [delta degree Fahrenheit (-9 to +9)] in case of relative setpoint knob configuration.
P		X	X				This is the throttling range for the proportional portion of the PID loop gain for the cooling control loop.
P		X	X				This is the throttling range for the proportional portion of the PID loop gain for the heating control loop.
P		X	X				This is the integral portion of the PID loop gain for the cooling control loop.
P		X	X				This is the integral portion of the PID loop gain for the heating control loop.
P		X	X				This is the derivative portion of the PID loop gain for the cooling control loop.
P		X	X				This is the derivative portion of the PID loop gain for the heating control loop.

(continued)

Table C-2. Control Parameters (Left Continued).

User Address	NvName	Field Name	Engineering Units: English (Metric) or States plus Range	Digital State or Value of State	Default
DaTempClCtrlBd	nciAux2SetPt	ubDisCbCoolS0	Degrees F 5 to 30 (3 to 17)		20
DaTempHtCtrlBd	nciAux2SetPt	ubDisCbHeatS0	Degrees F 5 to 30 (3 to 17)		20
DaTempEcCtrlBd	nciAux2SetPt	ubDisCbEconS0	Degrees F 5 to 30 (3 to 17)		20

Table C-2. Control Parameters (Right Continued).

E-Vision (EV): Calibrate (C), Monitor (M), Parameter (P), Schematic (S) Share (SH), Map (MA), Direct Access (DA) Hardware Configuration (HW), Manual Configuration (MN), Test (TS)							Comments
EV	SH	MA	DA	HW	MN	TS	
P		X	X				DisCbCool is the throttling range used for the cooling portion of the discharge air temperature cascade control loop.
P		X	X				DisCbHeat is the throttling range used for the heating portion of the discharge air temperature cascade control loop.
P		X	X				DisCbEcon is the throttling range used for the economizer control loop.

Table C-3. Energy Management Points(Left).

User Address	NvName	Field Name	Engineering Units: English (Metric) or States plus Range	Digital State or Value of State	Default
DestDlcShed	nviDlcShed		0 to 1		0
SchedOcc	nviTodEvent	CurrentState	SCHED_OCC SCHED_STDBY SCHED_UNOCC EVENT_ONE EVENT_TWO	0 1 2 3 4	SCHED_OCC
TodEventNext	nviTodEvent	NextState	SCHED_OCC SCHED_STDBY SCHED_UNOCC EVENT_ONE EVENT_TWO	0 1 2 3 4	SCHED_OCC
Tuncos	nviTodEvent	uiTimeToNextState	minutes 0 to 2880		0
	nviBypass	value	0 to 100		0
DestBypass	nviBypass	state	SW_OFF SW_ON SW_NUL	0 1 255	SW_NUL
SrcBypCt	nvoBypass	value	0 to 100		0
SrcBypass	nvoBypass	state	SW_OFF SW_ON SW_NUL	0 1 255	SW_NUL

Table C-3. Energy Management Points(Right).

E-Vision (EV): Calibrate (C), Monitor (M), Parameter (P), Schematic (S) Share (SH), Map (MA), Direct Access (DA) Hardware Configuration (HW), Manual Configuration (MN), Test (TS)							Comments
EV	SH	MA	DA	HW	MN	TS	
M	X	X	X		X		DlcShed is an input from an energy management system. When DlcShed is 0, the temperature control algorithm operates in a normal mode. When DlcShed is non-zero, the setpoint is shifted by Aux1SetPt.DlcBumpTemp in the energy saving direction.
M	X	X	X		X		CurrentState indicates the current scheduled occupancy state to the node. CurrentState is used along with other occupancy inputs to calculate the effective occupancy of the node. The valid states and meaning are as follows: SCHED_OCC means the energy management system is specifying occupied. SCHED_STDBY means the energy management system is specifying that the space is presently between occupied and unoccupied. SCHED_UNOCC means the energy management system is specifying that the space is presently unoccupied. EVENT_ONE, EVENT_TWO, and all unspecified values have the same result as SCHED_OCC.
M			X		X		NextState indicates the next scheduled occupancy state to the node. This information is required by the Excel 10 to perform the optimum start strategy. The space expected effective occupancy will be NextState in uiTimeToNextState minutes. The valid states and meaning are the same as for CurrentState.
M			X		X		TimeToNextState is the time in minutes until the next change of scheduled occupancy state.
							Bypass.value: The bypass state of one node may be shared with the bypass state of another node using nviBypass and nvoBypass. This allows a wall module at one node to be used to over ride the scheduled occupancy of another node. The node with Bypass bound normally does not have a wall module. See the Data1.EffectOcc and Data1.Override for more details. The valid states are as follows: If the state is SW_ON and the value is not zero then the node should bypass the time of day schedule (subject to occupancy arbitration logic). If the state is SW_NUL, the input is not available because it is not bound, the input is no longer being updated by the sender, or OC_BYPASS is no longer being called. This means that the same as SW_OFF. If the state is SW_OFF or other and the value is don't care, the node should not bypass the time of day schedule. If the state is SW_ON and the value is 0, then the node should not bypass the time of day schedule. If the node receives this combination of state and value, then state is set to SW_OFF.
M	X		X		X		Refer to nviBypass.value.
							nvoBypass.value: nvoBypass is the current occupancy state of the node for bypass schedule. The states have the following meanings: If the state is SW_OFF and the value is 0, then Data1.EffectOcc is not OC_BYPASS. If the state is SW_ON and the value is 100 percent, then Data1.EffectOcc is OC_BYPASS.
M	X		X				Refer to nvoBypass.value.

(continued)

Table C-3. Energy Management Points(Left Continued).

User Address	NvName	Field Name	Engineering Units: English (Metric) or States plus Range	Digital State or Value of State	Default
	nviFree1	value	0 to 100		0
DestFree1	nviFree1	state	SW_OFF SW_ON SW_NUL	0 1 255	SW_NUL
	nviFree2	value	0 to 100		0
DestFree2	nviFree2	state	SW_OFF SW_ON SW_NUL	0 1 255	SW_NUL
	nviWSHPEnable	value	0 to 100		0
DestWSHPEnable	nviWSHPEnable	state	SW_OFF SW_ON SW_NUL	0 1 255	SW_NUL
	nviTimeClk	value	0 to 100		0
DestTimeClk	nviTimeClk	state	SW_OFF SW_ON SW_NUL	0 1 255	SW_NUL

Table C-3. Energy Management Points(Right Continued).

E-Vision (EV): Calibrate (C), Monitor (M), Parameter (P), Schematic (S) Share (SH), Map (MA), Direct Access (DA) Hardware Configuration (HW), Manual Configuration (MN), Test (TS)							Comments
EV	SH	MA	DA	HW	MN	TS	
							Free1.value network variable controls the spare or Free digital output for auxiliary functions. nviFree1 controls the FREE1_OUT, FREE1_OUT_PULSE_ON, and FREE1_OUT_PULSE_OFF outputs. The states have the following meaning: If the state is SW_OFF, the corresponding free logical output (and therefore the physical output, if configured) is off. If the state is SW_ON and the value is 0, then the corresponding free logical output (and therefore the physical output, if configured) is off. If the node receives this combination of state and value, then state is set to SW_OFF. If the state is SW_ON and the value is not zero, then the corresponding free logical output (and therefore the physical output, if configured) is on. If the state is SW_NUL or other, then the network variable is not bound, the communications path from the sending node has failed, or the sending node has failed. The corresponding free logical output does not change if the network variable input fails.
M	X		X		X		Refer to Free1.value.
							Free2.value behaves the same as Free 1 value.
M	X		X		X		Refer to Free2.value.
							WSHPEnable.value is used to enable the compressor stages in heat pump applications. Typically nviWSHPEnable is bound to a water flow sensor that detects heating/cooling water supplied to the heat pump. If there is no water flowing the compressor is disabled. If the state is SW_OFF, the compressor is disabled in heat pump applications. If the state is SW_ON and the value is 0, the compressor is disabled in heat pump applications. If the node receives this combination of state and value, then state is set to SW_OFF. If the state is SW_ON and the value is not zero, the compressor is enabled in heat pump applications. If the state is SW_NUL or other, the network variable is not bound and is ignored.
							Refer to WSHPEnable.value.
							nviTimeClk.value: nviTimeClk allows a time clock at one node to be shared with other nodes over the network. nviTimeClk is ORed with the local time clock sensor and the results are placed in Data1.OccTimeClock. TimeClk is received from another node and may have the following values: If the state is SW_OFF, the space is scheduled to be unoccupied. If the state is SW_ON and the value is 0, the space is scheduled to be unoccupied. If the node receives this combination of state and value, then state is set to SW_OFF. If the state is SW_ON and the value is not zero, the space is scheduled to be occupied. If the state is SW_NUL or other and the value is don't care, the network variable is not bound and is ignored.
							Refer to nviTimeClk.value.

(continued)

Table C-3. Energy Management Points(Left Continued).

User Address	NvName	Field Name	Engineering Units: English (Metric) or States plus Range	Digital State or Value of State	Default
SrcTimeClkCt	nvoTimeClk	value	0 to 100		0
SrcTimeClk	nvoTimeClk	state	SW_OFF SW_ON SW_NUL	0 1 255	SW_NUL

Table C-3. Energy Management Points(Right Continued).

E-Vision (EV): Calibrate (C), Monitor (M), Parameter (P), Schematic (S) Share (SH), Map (MA), Direct Access (DA) Hardware Configuration (HW), Manual Configuration (MN), Test (TS)							Comments
EV	SH	MA	DA	HW	MN	TS	
							nvoTimeClk reports the current state of the physical time clock input. The output values have the following meanings: If the state is SW_OFF and the value is 0, the time clock input is configured and the input is open circuit. If SCHEDULE_MASTER_IN is configured, then the schedule master input must be shorted to ground to reach this state. If the state is SW_ON and the value is 100 percent, the time clock input is configured and the input is a closed circuit. If SCHEDULE_MASTER_IN is configured, then the schedule master input must be shorted to ground to reach this state. If the state is SW_NUL and the value is 0, the time clock input is not configured by Select or the SCHEDULE_MASTER_IN physical input is configured and the input is open (nvoIO.ScheduleMaster = 0).
							Refer to nvoTimeClk.value.

Table C-4. Status Points (Left).

User Address	NvName	Field Name	Engineering Units: English (Metric) or States plus Range	Digital State or Value of State	Default
	nroPgmVer	id[			RTU1
	nroPgmVer	major_ver			1
	nroPgmVer	minor_ver			0
	nroPgmVer	bug_ver			0
	nroPgmVer	node_type			1
SrcEmerg	nvoEmerg		EMERG_NORMAL EMERG_PRESSURIZE EMERG_DEPRESSURIZE EMERG_PURGE EMERG_SHUTDOWN EMERG_NUL	0 1 2 3 4 255	EMERG_NORMAL
	nvoAlarm	subnet	1 to 255		0
	nvoAlarm	node	0 to 127		0
	nvoAlarm	type	0 to 255		0

Table C-4. Status Points (Right).

E-Vision (EV): Calibrate (C), Monitor (M), Parameter (P), Schematic (S) Share (SH), Map (MA), Direct Access (DA) Hardware Configuration (HW), Manual Configuration (MN), Test (TS)							Comments
EV	SH	MA	DA	HW	MN	TS	
						ROM	A four byte ASCII string indicating the type of node (model).
						ROM	Software version.
						ROM	Software version.
						ROM	Software version.
						ROM	The NodeType is a numeric identifier that is stored in EPROM that identifies the Excel 10 node type. Whenever a new software version or upgrade is issued, this is reflected in nroPgmVer which typically is read by a network management node to identify the node type. The contents of nroPgmVer contain compatible model type information and is fixed at the time when the node software is compiled.
M	X		X				Emerg is an emergency output reflecting the state of the locally wired smoke detector. If Emerg is EMERG_NORMAL, then no smoke is being detected by the local sensor or that the smoke detector input is not configured. If Emerg is EMERG_PURGE, the locally wired smoke sensor is indicating a smoke condition. EMERG_PRESSURIZE, EMERG_DEPRESSURIZE, and EMERG_SHUTDOWN are not supported by Emerg. If Emerg is not configured then it is set to EMERG_NUL
							subnet is the LonWorks® subnet number (in domain entry 1 of the nodes domain table) to which the node is assigned.
							node is the LonWorks® node number (in domain entry 1 of the nodes domain table) assigned to the node.
							type is the alarm type being issued. When an alarm condition is no longer TRUE, type is set to the sum of the alarm conditions numeric value and the RETURN_TO_NORMAL numeric value. The type also is recorded in AlarmLog. When a new alarm is detected, just the corresponding numeric value for the alarm is reported. Refer to Table 12 (Excel 10 Alarms) in the System Engineering Guide for all the error conditions that may be reported.

(continued)

Table C-4. Status Points (Left Continued).

User Address	NvName	Field Name	Engineering Units: English (Metric) or States plus Range	Digital State or Value of State	Default
StatusAlmTyp	nvoAlarmStatus	alarm_bit[0] Byte Offset = 0 Bit Offset = 0 (InputNVFailAlrm)	FALSE TRUE	0 1	FALSE
	nvoAlarmStatus	alarm_bit[0] Byte Offset = 0 Bit Offset = 1 (NodeDisableAlrm)	FALSE TRUE	0 1	FALSE
	nvoAlarmStatus	alarm_bit[0] Byte Offset = 0 Bit Offset = 2 (SensorFailAlrm)	FALSE TRUE	0 1	FALSE
	nvoAlarmStatus	alarm_bit[0] Byte Offset = 0 Bit Offset = 3 (FrostProtectAlrm)	FALSE TRUE	0 1	FALSE
	nvoAlarmStatus	alarm_bit[0] Byte Offset = 0 Bit Offset = 4 (InvalidSetPtAlrm)	FALSE TRUE	0 1	FALSE
	nvoAlarmStatus	alarm_bit[0] Byte Offset = 0 Bit Offset = 5 (LossAirFlowAlrm)	FALSE TRUE	0 1	FALSE
	nvoAlarmStatus	alarm_bit[0] Byte Offset = 0 Bit Offset = 6 (DirtyFilterAlrm)	FALSE TRUE	0 1	FALSE
	nvoAlarmStatus	alarm_bit[0] Byte Offset = 0 Bit Offset = 7 (SmokeAlrm)	FALSE TRUE	0 1	FALSE
	nvoAlarmStatus	alarm_bit[1] Byte Offset = 1 Bit Offset = 0 (IaqOverRideAlrm)	FALSE TRUE	0 1	FALSE

Table C-4. Status Points (Right Continued).

E-Vision (EV): Calibrate (C), Monitor (M), Parameter (P), Schematic (S) Share (SH), Map (MA), Direct Access (DA) Hardware Configuration (HW), Manual Configuration (MN), Test (TS)							Comments
EV	SH	MA	DA	HW	MN	TS	
		X	X				alarm_bit[0] Byte Offset = 0 Bit Offset = 0 (InputNVFailAlrm) alarm_bit [ n ] contains a bit for every possible alarm condition. Each alarm type has a corresponding bit in alarm_bit[ n ] (Alarm.type: 1.24, without RETURN_TO_NORMAL).
							alarm_bit[0] Byte Offset = 0 Bit Offset = 1 (NodeDisableAlrm)
							alarm_bit[0] Byte Offset = 0 Bit Offset = 2 (SensorFailAlrm)
							alarm_bit[0] Byte Offset = 0 Bit Offset = 3 (FrostProtectAlrm)
							alarm_bit[0] Byte Offset = 0 Bit Offset = 4 (InvalidSetPtAlrm)
							alarm_bit[0] Byte Offset = 0 Bit Offset = 5 (LossAirFlowAlrm)
							alarm_bit[0] Byte Offset = 0 Bit Offset = 6 (DirtyFilterAlrm)
							alarm_bit[0] Byte Offset = 0 Bit Offset = 7 (SmokeAlrm)
							alarm_bit[1] Byte Offset = 1 Bit Offset = 0 (IaqOverRideAlrm)

(continued)

Table C-4. Status Points (Left Continued).

User Address	NvName	Field Name	Engineering Units: English (Metric) or States plus Range	Digital State or Value of State	Default
AlarmLog1	nvoAlarmLog	type[0] 0 to 255 (AlarmTypeLog0) (AlarmTypeLog1) (AlarmTypeLog2) (AlarmTypeLog3) (AlarmTypeLog4)	NO_ALARM INPUT_NV_FAILURE NODE_DISABLED SENSOR_FAILURE FROST_PROTECTION INVALID_SET_POINT LOSS_OF_AIR_FLOW DIRTY_FILTER SMOKE_ALARM IAQ_OVERRIDE LOW_LIM_ECON_CLOSE rINPUT_NV_FAILURE rNODE_DISABLED rSENSOR_FAILURE rFROST_PROTECTION rINVALID_SET_POINT rLOSS_OF_AIR_FLOW rDIRTY_FILTER rSMOKE_ALARM rIAQ_OVERRIDE rLOW_LIM_ECON_CLOSE ALARM_NOTIFY_DISABLED	0 1 2 3 4 5 6 7 8 9 10 129 130 131 132 133 134 135 136 137 138 255	NO_ALARM
	nvoData1 (nvoCtlDataG1)	FieldNo	UPDATE_ALL_FIELDS MODE_FIELD EFFECT_OCC_FIELD OVERRIDE_FIELD SCHED_OCC_FIELD OCC_TIME_CLOCK_FIELD NET_MAN_OCC_FIELD SEN_OCC_FILED ECON_ENABLE_FIELD PROOF_AIR_FLOW_FIELD CALC_OD_ENTHALPY_FIELD CALC_RA_ENTHALPY_FIELD HEAT_STAGES_ON_FIELD COOL_STAGES_ON_FIELD FREE1_OUT_FIELD FREE2_OUT_FIELD OCC_STATUS_OUT_FIELD FAN_ON_FIELD AUX_ECON_OUT_FIELD ECON_FLOAT_SYNCH_FIELD DLC_SHED_FIELD IAQ_OVERRIDE_FIELD SMOKE_MONITOR_FIELD WINDOW_OPEN_FIELD DIRTY_FILTER_FIELD SHUTDOWN_FIELD MON_SWITCH_FIELD WSHP_ENABLE_FIELD UPDATE_NO_FIELDS	0 1 2 3 4 5 6 7 8 9 10 11 12 13 14 15 16 17 18 19 20 21 22 23 24 25 26 27 127	UPDATE_ALL_FIELDS

Table C-4. Status Points (Right Continued).

E-Vision (EV): Calibrate (C), Monitor (M), Parameter (P), Schematic (S) Share (SH), Map (MA), Direct Access (DA) Hardware Configuration (HW), Manual Configuration (MN), Test (TS)							Comments
EV	SH	MA	DA	HW	MN	TS	
			X				type[0] 0 to 255 (AlarmTypeLog0) (AlarmTypeLog1) (AlarmTypeLog2) (AlarmTypeLog3) (AlarmTypeLog4) A supervisory node may poll the AlarmLog output for a short alarm history. The last five alarm reports sent via nvoAlarm are reported via AlarmLog. When ALARM_NOTIFY_DISABLED is entered into the log, further alarms or return to normals are not entered into the log, until alarm reporting is again enabled. If Alarm is bound and not being acknowledged, the last alarm report entered into AlarmLog is the one that was not acknowledged. See Alarm and AlarmStatus for related subjects. type [ n ] specifies the alarm that was issued via Alarm. See Alarm for the alarm types used in AlarmLog. The newest alarm is reported in type[ 0 ] and the oldest is reported in type[ 4 ]. When a new entry is made to the log, the oldest entry is lost.
							FieldNo: nvoData1 and nvoCtlDataG1 are output network variables indicating the node status. The information contained in these network variables are typically used to display the node status on an operator terminal, used in a trend log, or used in a control process. The information contained in nvoCtlDataG1 and nvoData1 are identical. nvoCtlDataG1 uses the SGPUC mechanism to update the status or values. The fields in nvoData are updated when network variables are polled by the receiver. Then every six seconds the difference between the field in nvoData and nvoCtlDataG is calculated. If the difference is significant the field is updated according to the SGPUC mechanism. FieldNo indicates which other data field in the SGPUC network variable has changed since the last time it was sent on the network according to the SGPUC mechanism. If FieldNo is UPDATE_ALL_FIELDS, then all fields have been updated. If FieldNo is UPDATE_NO_FIELDS, then no fields have been updated recently.

(continued)

Table C-4. Status Points (Left Continued).

User Address	NvName	Field Name	Engineering Units: English (Metric) or States plus Range	Digital State or Value of State	Default
StatusMode	nvoData1 (nvoCtlDataG1)	Mode	START_UP_WAIT HEAT COOL OFF_MODE DISABLED_MODE EMERG_HEAT SMOKE_EMERGENCY FREEZE_PROTECT MANUAL FACTORY_TEST FAN_ONLY	0 1 2 3 4 5 6 7 8 9 10	START_UP_WAIT
StatusOcc	nvoData1 (nvoCtlDataG1)	EffectOcc	OC_OCCUPIED OC_UNOCCUPIED OC_BYPASS OC_STANDBY OC_NUL	0 1 2 3 255	OC_NUL
StatusOvr	nvoData1 (nvoCtlDataG1)	Override	OC_OCCUPIED OC_UNOCCUPIED OC_BYPASS OC_STANDBY OC_NUL	0 1 2 3 255	OC_NUL
StatusSched	nvoData1 (nvoCtlDataG1)	SchedOcc	OC_OCCUPIED OC_UNOCCUPIED OC_BYPASS OC_STANDBY OC_NUL	0 1 2 3 255	OC_NUL

Table C-4. Status Points (Right Continued).

E-Vision (EV): Calibrate (C), Monitor (M), Parameter (P), Schematic (S) Share (SH), Map (MA), Direct Access (DA) Hardware Configuration (HW), Manual Configuration (MN), Test (TS)							Comments
EV	SH	MA	DA	HW	MN	TS	
		X					Mode: The result of the controller determining which mode of operation it currently is in. At each power-up, the controller remains in the Start-Up and Wait mode (a random time from 0 to 20 minutes that is based on the units network number). After that period, the mode changes to initialize actuators that will fully close the damper and valve actuators to insure full travel when under program control. The various other modes are due to normal operation as well as manual and network commands.
		X					EffectOcc: Result of controller supervising the various Occupied controlling inputs and deciding which one to use. See StatusinOcy, SchedOcc, ManualOcc and StatusOvrd.
		X					Override: Is the effective manual override state arbitrated from NetManOcc, the wall module override button and the Bypass Timer.
		X					SchedOcc: SchedOcc is calculated from OccTimeClock and nviTodEvent.CurrentState using the following logic: If nviTodEvent.CurrentState is OC_OCCUPIED and OccTimeClock is ST_NUL, then SchedOcc is OC_OCCUPIED. If nviTodEvent.CurrentState is OC_UNOCCUPIED and OccTimeClock is ST_NUL, then SchedOcc is OC_UNOCCUPIED. If nviTodEvent.CurrentState is OC_STANDBY and OccTimeClock is ST_NUL, then SchedOcc is OC_STANDBY. If nviTodEvent.CurrentState is don't care and OccTimeClock is ST_ON, then SchedOcc is OC_OCCUPIED. If nviTodEvent.CurrentState is don't care and OccTimeClock is ST_OFF, then SchedOcc is OC_UNOCCUPIED. OC_OCCUPIED means the space is scheduled to be occupied. OC_UNOCCUPIED means the space is scheduled to be unoccupied. OC_STANDBY means the space is scheduled to be in a standby state somewhere between OC_OCCUPIED and OC_UNOCCUPIED.

(continued)

Table C-4. Status Points (Left Continued).

User Address	NvName	Field Name	Engineering Units: English (Metric) or States plus Range	Digital State or Value of State	Default
TimeCkckOcc	nvoData1 (nvoCtlDataG1)	OccTimeClock	ST_OFF ST_LOW ST_MED ST_HIGH ST_ON ST_NUL	0 1 2 3 4 255	ST_NUL
StatusManOcc	nvoData1 (nvoCtlDataG1)	NetManOcc	OC_OCCUPIED OC_UNOCCUPIED OC_BYPASS OC_STANDBY OC_NUL	0 1 2 3 255	OC_NUL
StatusOcySen	nvoData1 (nvoCtlDataG1)	SenOcc	OC_OCCUPIED OC_UNOCCUPIED OC_BYPASS OC_STANDBY OC_NUL	0 1 2 3 255	OC_NUL
StatusEconEn	nvoData1 (nvoCtlDataG1)	EconEnable	ST_OFF ST_LOW ST_MED ST_HIGH ST_ON ST_NUL	0 1 2 3 4 255	ST_NUL
SaFanStatus	nvoData1 (nvoCtlDataG1)	ProofAirFlow	ST_OFF ST_LOW ST_MED ST_HIGH ST_ON ST_NUL	0 1 2 3 4 255	ST_NUL

Table C-4. Status Points (Right Continued).

E-Vision (EV): Calibrate (C), Monitor (M), Parameter (P), Schematic (S) Share (SH), Map (MA), Direct Access (DA) Hardware Configuration (HW), Manual Configuration (MN), Test (TS)							Comments
EV	SH	MA	DA	HW	MN	TS	
		X					<p>OccTimeClock: OccTimeClock shows the state of the physical time clock input via nvoIO.OccTimeClock ORed with nviTimeClk. Valid enumerated values are: ST_OFF means OC_UNOCCUPIED when either the time clock input is configured and nvoIO.OccTimeClock is 0 and nviTimeClk is not SW_ON or nviTimeClk.state is SW_OFF and nvoIO.OccTimeClock is not 1. ST_ON means OC_OCCUPIED when either the time clock input is configured and nvoIO.OccTimeClock is 1 or nviTimeClk.state is SW_ON. ST_NUL means that the local time clock input is not configured by nciIOSelect and nviTimeClk.state is SW_NUL. There is no time clock configured or bound to the node.</p>
		X					<p>NetManOcc: NetManOcc reports the network manual occupancy state from nviManOcc. The valid enumerated states are: OC_OCCUPIED indicates occupied OC_UNOCCUPIED indicates not occupied OC_BYPASS indicates that the space is bypass occupied for nciAux2SetPt.uiBypassTime seconds after nviManOcc is first set to OC_BYPASS OC_STANDBY indicates that the space is standby. OC_NUL means that no manual over ride is active.</p>
		X					<p>SenOcc: SenOcc indicates the current state of the sensed occupancy and is calculated from nviSensorOcc and the local occupancy sensor via nvoIO.OccupancySensor. The local sensor and nviSensorOcc are ORed together. If either the local sensor or nviSensorOcc shows occupancy, then SenOcc shows occupancy. The valid enumerated values are: OC_OCCUPIED means that occupancy is sensed by one or more sensor. OC_UNOCCUPIED means that no occupancy is sensed by any sensors. OC_NUL means no local sensor is configured and nviSensorOcc has failed to be received periodically (bound or not bound).</p>
		X					<p>EconEnable: EconEnable indicates the current suitability of outdoor air for use in cooling used by the control process EconEnable is periodically calculated either from the sensor(s) specified by nciConfig.EconEnable or from nviEcon. When nviEcon.state is not SW_NUL, then the local inputs are ignored and nviEcon.state is used instead. See nciConfig.EconEnable. The valid enumerated values are: ST_OFF means the outdoor air is not suitable to augment cooling. ST_ON means the outdoor air is suitable to augment cooling. ST_NUL means no local sensor is selected by nciConfig.EconEnable, or the selected local sensor has failed or has not been configured by nciIOSelect, and that nviEcon.state is SW_NUL. The outdoor air is considered unsuitable for cooling.</p>
		X					<p>ProofAirFlow: ProofAirFlow indicates the current state of the ProofAirFlow switch used by the control process and is read by the local sensor via nvoIO.ProofAirFlow. The valid enumerated values are: ST_OFF means air flow is not detected. ST_ON means air flow is detected. ST_NUL means no air flow switch is configured.</p>

(continued)

Table C-4. Status Points (Left Continued).

User Address	NvName	Field Name	Engineering Units: English (Metric) or States plus Range	Digital State or Value of State	Default
OaEnthCalc	nvoData1 (nvoCtlDataG1)	siCalcODeenthalpyS7	btu/lb 0 to 100		SI_INVALID
RaEnthCalc	nvoData1 (nvoCtlDataG1)	siCalcRAEnthalpyS7	btu/lb 0 to 100		SI_INVALID
HeatStgsOn	nvoData1 (nvoCtlDataG1)	HeatStagesOn	0 to 4		0
CoolStgsOn	nvoData1 (nvoCtlDataG1)	CoolStagesOn	0 to 4		0
Free1Stat	nvoData1 (nvoCtlDataG1)	Free1Out	FALSE TRUE	0 1	FALSE
Free2Stat	nvoData1 (nvoCtlDataG1)	Free2Out	FALSE TRUE	0 1	FALSE
OccStatOut	nvoData1 (nvoCtlDataG1)	OccStatusOut	FALSE TRUE	0 1	FALSE
SaFan	nvoData1 (nvoCtlDataG1)	FanOn	FALSE TRUE	0 1	FALSE
StatusEconOut	nvoData1 (nvoCtlDataG1)	AuxEconOut	FALSE TRUE	0 1	FALSE
	nvoData1 (nvoCtlDataG1)	EconFloatSynch	FALSE TRUE	0 1	FALSE

Table C-4. Status Points (Right Continued).

E-Vision (EV): Calibrate (C), Monitor (M), Parameter (P), Schematic (S) Share (SH), Map (MA), Direct Access (DA) Hardware Configuration (HW), Manual Configuration (MN), Test (TS)							Comments
EV	SH	MA	DA	HW	MN	TS	
		X					siCalcODEnthalpyS7: siCalcODEnthalpyS7 is the calculated outdoor air enthalpy in btu / lb calculated from the siOutdoorTempS7 and ubOutdoorHumidityS1. siCalcODEnthalpyS7 is used to determine the suitability of outside air for cooling when nciConfig.EconEnable is SINGLE_ENTH and both outdoor temperature and humidity sensors are present. siCalcODEnthalpyS7 is compared to the enthalpy setpoint stored in nciAux1SetPts.ubOdEnthalpyEnableS2.
		X					siCalcRAEnthalpyS7: siCalcRAEnthalpyS7 is the calculated return air enthalpy in btu / lb calculated from the siReturnTempS7 and ubReturnHumidityS1. siCalcRAEnthalpyS7 is used to determine the suitability of outside air for cooling when nciConfig.EconEnable is DIFF_ENTH and both outdoor and return (or space) temperature sensors and humidity sensors are present. Sensors may be physically connected to the node or available over the network.
		X					HeatStagesOn: HeatStagesOn indicates how many heating stages are on. If the node is controlling a heat pump, HeatStagesOn indicates how many auxiliary heating stages are turned on.
		X					CoolStagesOn: CoolStagesOn indicates how many compressor stages are on. If the node is controlling a heat pump, compressor stages are turned on for both heating or cooling.
		X					Free1Out: Free1Out indicates the state of FREE1_OUT digital output. 1 means on, and 0 means off.
		X					Free2Out: Free2Out indicates the state of FREE2_OUT digital output. 1 means on, and 0 means off.
		X					OccStatusOut: OccStatusOut indicates the state of the OCCUPANCY_STATUS_OUT digital output. 1 means on (not OC_UNOCCUPIED), and 0 means off (OC_UNOCCUPIED).
		X					FanOn: FanOn indicates the state of the FAN_OUT digital output. 1 means on, and 0 means off.
		X					AuxEconOut: AuxEconOut indicates the state of the AUX_ECON_OUT digital output. 1 means that the packaged economizer is enabled, and 0 means the economizer is disabled. A packaged economizer is always treated as the first stage of cooling when an economizer is configured by nciloSelect.
							EconFloatSynch: EconFloatSynch indicates that the economizer damper motor is being synchronized with the reported economizer position by driving the damper for a period longer than it takes to fully close the damper. The reported economizer position is synchronized whenever an endpoint is reached (full open or full close).and when the elapsed time since the last synchronization is 24 hours.

(continued)

Table C-4. Status Points (Left Continued).

User Address	NvName	Field Name	Engineering Units: English (Metric) or States plus Range	Digital State or Value of State	Default
DlcShed	nvoData1 (nvoCtlDataG1)	DlcShed	FALSE TRUE	0 1	FALSE
StatusIaqOvr	nvoData1 (nvoCtlDataG1)	IaqOverRide	FALSE TRUE	0 1	FALSE
StatusSmoke	nvoData1 (nvoCtlDataG1)	SmokeMonitor	FALSE TRUE	0 1	FALSE
StatusWndw	nvoData1 (nvoCtlDataG1)	WindowOpen	FALSE TRUE	0 1	FALSE
StatusFilter	nvoData1 (nvoCtlDataG1)	DirtyFilter	FALSE TRUE	0 1	FALSE
ShutDown	nvoData1 (nvoCtlDataG1)	ShutDown	FALSE TRUE	0 1	FALSE
MonitorSw	nvoData1 (nvoCtlDataG1)	MonSwitch	FALSE TRUE	0 1	FALSE

Table C-4. Status Points (Right Continued).

E-Vision (EV): Calibrate (C), Monitor (M), Parameter (P), Schematic (S) Share (SH), Map (MA), Direct Access (DA) Hardware Configuration (HW), Manual Configuration (MN), Test (TS)							Comments
EV	SH	MA	DA	HW	MN	TS	
							<p>DlcShed: DlcShed indicates the state of nviDlcShed. When DlcShed is 1, demand limit control set by an energy management node is active. If the effective occupancy is OC_OCCUPIED or OC_STANDBY when demand limit control is active, then the setpoint is shifted by nciAux1SetPt.siDlcBumpTempS7 in the energy saving direction. When DlcShed is 0, demand limit control is inactive. If nviDlcShed fails to be received periodically or nviDlcShed becomes 0, then the setpoint is ramped back to the original setpoint over a 30 minute interval.</p>
		X					<p>laqOverride: When an economizer is configured, laqOverride indicates the current state of the indoor air quality, an is used by the control process to open the economizer damper to let in more outside air. 1 means poor indoor air quality, and 0 means indoor air quality is OK. When laqOverride is 1, the IAQ_OVERRIDE alarm is initiated.</p> <p>laqOverride indicates poor air quality if the analog sensor OR a digital sensor (local or via network) shows poor air quality. Specifically, if nvoData2.siSpaceCo2S0 is not SI_INVALID, and exceeds nciAux1SetPt.siCO2laqLimitS0, then poor air quality is detected. Also if nviIaqOvr.state is SW_ON, then poor air quality is detected. Or if a local digital input is configured as IAQ_OVERRIDE_IN and nvoI.laqOverride is 1 then poor air quality is also detected. When poor air quality is detected, the economizer minimum position is set to nciAux1SetPts.ubEconlaqPosS0, instead of nciAux1SetPts.ubEconMinPosS0. When an economizer is not configured, laqOverride is 0.</p>
		X					<p>SmokeMonitor: SmokeMonitor indicates the current state of the SmokeMonitor input used by the control process and is read from another node via nviEmerg or the local sensor via nvoI.SmokeMonitor. If either nviEmerg is not EMERG_NORMAL or nvoI.SmokeMonitor is 1, then SmokeMonitor is 1 meaning that smoke is detected. Otherwise SmokeMonitor is 0, meaning smoke is not detected. When smoke monitor is 1, the algorithm controls as per the settings found in nciConfig.SmokeControl.</p>
		X					<p>WindowOpen: WindowOpen indicates the current state of the window sensors and is calculated from nviWindow state and the local occupancy sensor via nvoI.WindowOpen. The local sensor and nviWindow are ORed together. If either the local sensor or nviWindow shows that the window is open (nvoI.WindowOpen = 1 or nviWindow.state = SW_ON), then WindowOpen shows that the window is open. 1 means that the window is open and 0 means that the window is closed. When the window is open, the controller mode is switched to FREEZE_PROTECT.</p>
		X					<p>DirtyFilter: DirtyFilter indicates the state of the air filter via the nvoI.DirtyFilter digital input or the nvoData1.siFilterPressureS10 analog input. If nvoData1.siFilterPressureS10 exceeds nciAux2SetPt.ubFilterPressStPtS5, a dirty filter is indicated. DirtyFilter is set to 1 when a dirty filter has been detected by either method for one minute. DirtyFilter is set to 0 when a dirty filter has not been detected by either method for one minute. When DirtyFilter is 1, a DIRTY_FILTER alarm is generated.</p>
		X					<p>ShutDown: ShutDown indicates the state of the ShutDown input via nvoI.ShutDown. 1 means a ShutDown is being commanded and 0 means normal operation.</p>
		X					<p>MonSwitch: MonSwitch is the state of the digital input wired to a general purpose monitor switch via nvoI.MonSwitch. 1 means that the switch is closed and 0 means that the switch is open.</p>

(continued)

Table C-4. Status Points (Left Continued).

User Address	NvName	Field Name	Engineering Units: English (Metric) or States plus Range	Digital State or Value of State	Default
	nvoData1 (nvoCtlDataG1)	WSHPEnable	FALSE TRUE	0 1	FALSE
	nvoData2 (nvoCtlDataG2)	FieldNo	UPDATE_ALL_FIELDS BYPASS_TIMER_FIELD TEMP_CONTROL_PT_FIELD SPACE_TEMP_FIELD DISCHARGE_TEMP_FIELD DISCHARGE_SET_PT_FIELD RETURN_TEMP_FIELD RETURN_HUMIDITY_FIELD RETURN_ENTHALPY_FIELD OUTDOOR_TEMP_FIELD OUTDOOR_HUMIDITY_FIELD OUTDOOR_ENTHALPY_FIELD FILTER_PRESSURE_FIELD SPACE_CO2_FIELD MONITOR_VOLTS_FIELD COOL_POS_FIELD HEAT_POS_FIELD ECON_POS_FIELD UPDATE_NO_FIELDS		UPDATE_ALL_FIELDS
BypTimer	nvoData2 (nvoCtlDataG2)	uiBypassTimer	minutes 0 to 2880		0
RmTempActSpt	nvoData2 (nvoCtlDataG2)	siTempControlPtS7	Degrees F 50 to 85 degrees C (10 to 29)		SI_INVALID
RmTemp	nvoData2 (nvoCtlDataG2)	siSpaceTempS7	Degrees F 40 to 100 degrees C (4 to 38)		SI_INVALID

Table C-4. Status Points (Right Continued).

E-Vision (EV): Calibrate (C), Monitor (M), Parameter (P), Schematic (S) Share (SH), Map (MA), Direct Access (DA) Hardware Configuration (HW), Manual Configuration (MN), Test (TS)							Comments
EV	SH	MA	DA	HW	MN	TS	
		X					<p>WSHPEnable:</p> <p>WSHPEnable reports the state of the current state of nviWSHPEnable. The states for nviWSHPEnable are as follows: If nviWSHPEnable.state is SW_OFF and the nviWSHPEnable.value is 0, then WSHPEnable is 0 (Disable Water Source Heat Pump). If nviWSHPEnable.state is SW_ON and the nviWSHPEnable.value is 0, then WSHPEnable is 0 (Disable Water Source Heat Pump). If nviWSHPEnable.state is SW_ON and the nviWSHPEnable.value is not 0, then WSHPEnable is 1 (Enable Water Source Heat Pump). If nviWSHPEnable.state is SW_NUL and the nviWSHPEnable.value is any value, then WSHPEnable is 1 (Enable Water Source Heat Pump when nviWSHPEnable is not bound to another node).</p>
							<p>nvoData2. FieldNo: nvoData2 and nvoCtlDataG2 are output network variables indicating the node status. The information contained in these network variables are typically used to display the node status on an operator terminal, used in a trend log, or used in a control process. The information contained in nvoCtlDataG2 and nvoData2 are identical. nvoData2 is a polled network variable and must be polled by the receiver. nvoCtlDataG2 uses the SGPUC mechanism. FieldNo indicates which other data field in the SGPUC network variable has changed since the last time it was sent on the network according to the SGPUC mechanism.</p>
		X					<p>uiBypassTimer:</p> <p>The time left in the bypass timer is uiBypassTimer minutes. If uiBypassTimer is zero, then the bypass timer is not running. If uiBypassTimer is not zero, it is decremented every minute.</p>
		X					<p>siTempControlPtS7:</p> <p>The current temperature control point (such that, the current actual space temperature setpoint which the controller is presently trying to maintain in the conditioned space) is calculated from the various Setpoints, operating modes, network variable inputs, and optimum start-up parameters. The final result is stored in siTempControlPtS7.</p>
							<p>siSpaceTempS7:</p> <p>siSpaceTempS7 is the space temperature used by the control process and is read from another node via nviSpaceTemp or a local sensor via nvoIO.siSpaceTempS7 or nvoIO.siReturnTempS7. If the network input is not SI_INVALID, then the network input has priority. The local sensor is selected by nciConfig.ControlUsesRtnAirTemp. When nciConfig.ControlUsesRtnAirTemp is 0, then the space temperature sensor is selected. When nciConfig.ControlUsesRtnAirTemp is 1, then the return temperature sensor is selected. If the network input and the selected local sensor has failed or are not configured, siSpaceTempS7 is SI_INVALID.</p>

(continued)

Table C-4. Status Points (Left Continued).

User Address	NvName	Field Name	Engineering Units: English (Metric) or States plus Range	Digital State or Value of State	Default
DaTemp	nvoData2 (nvoCtlDataG2)	siDischargeTempS7	Degrees F 30 to 122 Degrees C (-1 to 50)		SI_INVALID
DaSetpt	nvoData2 (nvoCtlDataG2)	siDischargeSetPtS7	Degrees F 30 to 122 Degrees C (-1 to 50)		SI_INVALID
RaTemp	nvoData2 (nvoCtlDataG2)	siReturnTempS7	Degrees F 30 to 122 Degrees C (-1 to 50)		SI_INVALID
RaHum	nvoData2 (nvoCtlDataG2)	ubReturnHumidityS1	Percentage 10 to 90		UB_INVALID
RaEnth	nvoData2 (nvoCtlDataG2)	siReturnEnthalpyS7	mA 4 to 20		SI_INVALID
OaTemp	nvoData2 (nvoCtlDataG2)	siOutdoorTempS7	Degrees F -40 to 122 Degrees C (-40 to 43)		SI_INVALID
OaHum	nvoData2 (nvoCtlDataG2)	ubOutdoorHumidityS1	Percentage 10 to 90		UB_INVALID
OaEnth	nvoData2 (nvoCtlDataG2)	siOutdoorEnthalpyS7	mA 4 to 20		SI_INVALID
FilterPress	nvoData2 (nvoCtlDataG2)	siFilterPressureS10	inw (kPa) 0 to 5 (0 to 1.25)		SI_INVALID

Table C-4. Status Points (Right Continued).

E-Vision (EV): Calibrate (C), Monitor (M), Parameter (P), Schematic (S) Share (SH), Map (MA), Direct Access (DA) Hardware Configuration (HW), Manual Configuration (MN), Test (TS)							Comments
EV	SH	MA	DA	HW	MN	TS	
		X					siDischargeTempS7: siDischargeTempS7 is the discharge air temperature used by the control process and is read from the local sensor via nvoI.O.siDischargeTempS7. If the sensor has failed or is not configured, siDischargeTempS7 is SI_INVALID.
		X					siDischargeSetPtS7: siDischargeSetPtS7 is the calculated desired discharge air temperature when cascade control is being used.
		X					siReturnTempS7: siReturnTempS7 is the return air temperature used by the control process read from the local sensor via nvoI.O.siReturnTempS7. If the sensor has failed or is not configured, siReturnTempS7 is SI_INVALID.
		X					ubReturnHumidityS1: ubReturnHumidityS1 is the return air humidity used by the control process and is read from the local sensor via nvoI.O.ReturnHumidity. If the sensor has failed or is not configured ubReturnHumidityS1 is UB_INVALID.
		X					siReturnEnthalpyS7: siReturnEnthalpyS7 is the return air enthalpy used by the control process and is read from the local sensor via nvoI.O.siReturnEnthalpyS7. If the sensor has failed or is not configured, siReturnEnthalpyS7 is SI_INVALID.
		X					siOutdoorTempS7: siOutdoorTempS7 is the outdoor air temperature used by the control process and is read from another node via nviOdTemp or the local sensor via nvoI.O.siOutdoorTempS7. If the network input is not SI_INVALID, then the network input has priority. If both the network input and the local sensor have failed or are not configured, siOutdoorTempS7 is SI_INVALID.
		X					ubOutdoorHumidityS1: ubOutdoorHumidityS1 is the outdoor air humidity used by the control process and is read from another node via nviOdHum or the local sensor via nvoI.O.OutdoorHumidity. If the network is not SI_INVALID, then the network input has priority. If both the network input and the local sensor have failed or are not configured, ubOutdoorHumidityS1 is UB_INVALID.
		X					siOutdoorEnthalpyS7: siOutdoorEnthalpyS7 is the outdoor air enthalpy used by the control process and is read from another node via nviOdEnthS7 or the local sensor via nvoI.O.siOutdoorEnthalpyS7. If the network input is not SI_INVALID, then the network input has priority. If both the network input and the local sensor have failed or are not configured, siOutdoorEnthalpyS7 is SI_INVALID.
		X					siFilterPressureS10: siFilterPressureS10 is air pressure across the air filter used by the control process and is read from the local sensor via nvoI.O.siFilterPressureS10. If the local sensor has failed or is not configured, siFilterPressureS10 is SI_INVALID.

(continued)

Table C-4. Status Points (Left Continued).

User Address	NvName	Field Name	Engineering Units: English (Metric) or States plus Range	Digital State or Value of State	Default
CO2Sens	nvoCtlDataG2	siSpaceCo2S0	PPM 150 to 2000		SI_INVALID
MonitorSens	nvoCtlDataG2	siMonitor1S10	volts 1 to 10		SI_INVALID
CoolPos	nvoCtlDataG2	sbCoolPosS0	Percentage 0 to 100		0
HeatPos	nvoCtlDataG2	sbHeatPosS0	Percentage 0 to 100		0
EconPos	nvoCtlDataG2	sbEconPosS0	Percentage 0 to 100		0
StatusError	nvoError	error_bit[0] Byte Offset = 0 Bit Offset = 0 (SpaceTempError)	FALSE TRUE	0 1	FALSE
	nvoError	error_bit[0] Byte Offset = 0 Bit Offset = 1 (SetPtError)	FALSE TRUE	0 1	FALSE
	nvoError	error_bit[0] Byte Offset = 0 Bit Offset = 2 (OdTempError)	FALSE TRUE	0 1	FALSE
	nvoError	error_bit[0] Byte Offset = 0 Bit Offset = 3 (OdHumError)	FALSE TRUE	0 1	FALSE
	nvoError	error_bit[0] Byte Offset = 0 Bit Offset = 4 (OdEnthalpyError)	FALSE TRUE	0 1	FALSE
	nvoError	error_bit[0] Byte Offset = 0 Bit Offset = 5 (DischgTempError)	FALSE TRUE	0 1	FALSE
	nvoError	error_bit[0] Byte Offset = 0 Bit Offset = 6 (RtnTempError)	FALSE TRUE	0 1	FALSE
	nvoError	error_bit[0] Byte Offset = 0 Bit Offset = 7 (RtnHumError)	FALSE TRUE	0 1	FALSE

Table C-4. Status Points (Right Continued).

E-Vision (EV): Calibrate (C), Monitor (M), Parameter (P), Schematic (S) Share (SH), Map (MA), Direct Access (DA) Hardware Configuration (HW), Manual Configuration (MN), Test (TS)							Comments
EV	SH	MA	DA	HW	MN	TS	
		X					siSpaceCo2S0: siSpaceCo2S0 is the indoor air CO <sub>2</sub> content used by the control process and read the local sensor via nvoIO.siSpaceCo2S0. If the local sensor has failed or is not configured, siSpaceCo2S0 is SI_INVALID.
		X					siMonitor1S10: siMonitor1S10 is the voltage applied at the monitor input terminals. If the sensor is not configured or has failed, the value is SI_INVALID.
		X					sbCoolPosS0: If the node is configured for modulating cool, sbCoolPosS0 shows the current position of the cooling modulating output.
		X					sbHeatPosS0: If the node is configured for modulating heat, sbHeatPosS0 shows the current position of the heating modulating output.
		X					sbEconPosS0: If the node is configured for modulating economizer, sbEconPosS0 shows the current position of the economizer modulating output.
			X				For SpaceTempError, a value of 1 (TRUE) indicates that data was not available from the sensor and will result in a SENSOR_FAILURE alarm. A value of 0 (FALSE) indicates a normal condition. The heating and cooling control loops will be turned off if there is a space temp sensor failure. The fan will remain under normal control.
							For SetPtError, see preceding. Upon a failure of the local setpoint, the control loop will use the default occupied setpoints to control space temperature.
							For OdTempError, see preceding. All control functions associated with the failed sensor are disabled as if the sensor was not configured.
							For OdHumError, see preceding. A value of 0 (FALSE) indicates a normal condition. All control functions associated with the failed sensor are disabled as if the sensor was not configured.
							OdEnthalpyError: All control functions associated with the failed sensor are disabled as if the sensor was not configured.
							DischgTempError: All control functions associated with the failed sensor are disabled as if the sensor was not configured.
							RtnTempError: All control functions associated with the failed sensor are disabled as if the sensor was not configured.
							RtnHumError: All control functions associated with the failed sensor are disabled as if the sensor was not configured.

(continued)

Table C-4. Status Points (Left Continued).

User Address	NvName	Field Name	Engineering Units: English (Metric) or States plus Range	Digital State or Value of State	Default
	nvoError	error_bit[1] Byte Offset = 1 Bit Offset = 0 (RtnEnthalpyError)	FALSE TRUE	0 1	FALSE
	nvoError	error_bit[1] Byte Offset = 1 Bit Offset = 1 (MonitorSensorError)	FALSE TRUE	0 1	FALSE
	nvoError	error_bit[1] Byte Offset = 1 Bit Offset = 2 (SpaceCO2Error)	FALSE TRUE	0 1	FALSE
	nvoError	error_bit[1] Byte Offset = 1 Bit Offset = 3 (FilterStaticPresError)	FALSE TRUE	0 1	FALSE
	nvoError	error_bit[1] Byte Offset = 1 Bit Offset = 4 (ADCalError)	FALSE TRUE	0 1	FALSE
	nvoError	error_bit[1] Byte Offset = 1 Bit Offset = 7 (nvApplModeError)	FALSE TRUE	0 1	FALSE
	nvoError	error_bit[2] Byte Offset = 2 Bit Offset = 0 (nvSetPtOffsetError)	FALSE TRUE	20 1	FALSE
	nvoError	error_bit[2] Byte Offset = 2 Bit Offset = 1 (nvSpaceTempError)	FALSE TRUE	0 1	FALSE
	nvoError	error_bit[2] Byte Offset = 2 Bit Offset = 2 (nvOdTempError)	FALSE TRUE	0 1	FALSE
	nvoError	error_bit[2] Byte Offset = 2 Bit Offset = 3 (nvOdHumError)	FALSE TRUE	0 1	FALSE
	nvoError	error_bit[2] Byte Offset = 2 Bit Offset = 4 (nvSensorOccError)	FALSE TRUE	0 1	FALSE

Table C-4. Status Points (Right Continued).

E-Vision (EV): Calibrate (C), Monitor (M), Parameter (P), Schematic (S) Share (SH), Map (MA), Direct Access (DA) Hardware Configuration (HW), Manual Configuration (MN), Test (TS)							Comments
EV	SH	MA	DA	HW	MN	TS	
							RtnEnthalpyError: All control functions associated with the failed sensor are disabled as if the sensor was not configured.
							MonitorSensorError: All control functions associated with the failed sensor are disabled as if the sensor was not configured.
							SpaceCO2Error: All control functions associated with the failed sensor are disabled as if the sensor was not configured.
							FilterStaticPresError: All control functions associated with the failed sensor are disabled as if the sensor was not configured.
							ADCaError: All control functions associated with the failed sensor are disabled as if the sensor was not configured.
							ApplModeError: All control functions associated with the failed sensor are disabled as if the sensor was not configured.
							SetPtOffsetError: All control functions associated with the failed sensor are disabled as if the sensor was not configured.
							SpaceTempError: All control functions associated with the failed sensor are disabled as if the sensor was not configured.
							OdTempError: All control functions associated with the failed sensor are disabled as if the sensor was not configured.
							OdHumError: All control functions associated with the failed sensor are disabled as if the sensor was not configured.
							SensorOccError: All control functions associated with the failed sensor are disabled as if the sensor was not configured.

(continued)

Table C-4. Status Points (Left Continued).

User Address	NvName	Field Name	Engineering Units: English (Metric) or States plus Range	Digital State or Value of State	Default
	nvoError	error_bit[2] Byte Offset = 2 Bit Offset = 5 (nvWindowError)	FALSE TRUE	0 1	FALSE
	nvoError	error_bit[2] Byte Offset = 2 Bit Offset = 6 (nvDlcShedError)	FALSE TRUE	0 1	FALSE
	nvoError	error_bit[2] Byte Offset = 2 Bit Offset = 7 (nvTodEventError)	FALSE TRUE	0 1	FALSE
	nvoError	error_bit[3] Byte Offset = 3 Bit Offset = 0 (nvByPassError)	FALSE TRUE	0 1	FALSE
	nvoError	error_bit[3] Byte Offset = 3 Bit Offset = 1 (nvOdEnthalpyError)	FALSE TRUE	0 1	FALSE
	nvoError	error_bit[3] Byte Offset = 3 Bit Offset = 2 (nvEconError)	FALSE TRUE	0 1	FALSE
	nvoError	error_bit[3] Byte Offset = 3 Bit Offset = 3 (nvlaqOverrideError)	FALSE TRUE	0 1	FALSE
	nvoError	error_bit[3] Byte Offset = 3 Bit Offset = 4 (nvFree1Error)	FALSE TRUE	0 1	FALSE
	nvoError	error_bit[3] Byte Offset = 3 Bit Offset = 5 (nvFree2Error)	FALSE TRUE	0 1	FALSE
	nvoError	error_bit[3] Byte Offset = 3 Bit Offset = 6 (nvTimeClockError)	FALSE TRUE	0 1	FALSE
	nvoError	error_bit[3] Byte Offset = 3 Bit Offset = 7 (nvWSHPEnError)	FALSE TRUE	0 1	FALSE
NetConfig	nciNetConfig		CFG_LOCAL CFG_EXTERNAL CFG_NUL	0 1 255	CFG_LOCAL

Table C-4. Status Points (Right Continued).

E-Vision (EV): Calibrate (C), Monitor (M), Parameter (P), Schematic (S) Share (SH), Map (MA), Direct Access (DA) Hardware Configuration (HW), Manual Configuration (MN), Test (TS)							Comments
EV	SH	MA	DA	HW	MN	TS	
							WindowError: All control functions associated with the failed sensor are disabled as if the sensor was not configured.
							DlcShedError: All control functions associated with the failed sensor are disabled as if the sensor was not configured.
							TodEventError: All control functions associated with the failed sensor are disabled as if the sensor was not configured.
							ByPassError: All control functions associated with the failed sensor are disabled as if the sensor was not configured.
							OdEnthalpyError: All control functions associated with the failed sensor are disabled as if the sensor was not configured.
							EconError: All control functions associated with the failed sensor are disabled as if the sensor was not configured.
							laqOverrideError: All control functions associated with the failed sensor are disabled as if the sensor was not configured.
							Free1Error: All control functions associated with the failed sensor are disabled as if the sensor was not configured.
							Free2Error: All control functions associated with the failed sensor are disabled as if the sensor was not configured.
							TimeClockError: All control functions associated with the failed sensor are disabled as if the sensor was not configured.
							WSHPEnError: All control functions associated with the failed sensor are disabled as if the sensor was not configured.
							All nodes that support self-installation provide a configuration variable to allow a network management tool to also install the node. nciNetConfig is only used by a network management tool and may have the following values: CFG_LOCAL - Node will use self installation functions to set its own network image. CFG_EXTERNAL - The nodes network image has been set by an external source.

Table C-5. Calibration Points (Left).

User Address	NvName	Field Name	Engineering Units: English (Metric) or States plus Range	Digital State or Value of State	Default
	nvoRaw	K1Raw K2Raw Ai1Resistive Ai2Resistive Ai3Voltage Ai4Voltage RawSpaceTemp RawSetPoint	Counts 0 to 65535		0

Table C-5. Calibration Points (Right).

E-Vision (EV): Calibrate (C), Monitor (M), Parameter (P), Schematic (S) Share (SH), Map (MA), Direct Access (DA) Hardware Configuration (HW), Manual Configuration (MN), Test (TS)							Comments
EV	SH	MA	DA	HW	MN	TS	
							raw_data contains the analog to digital converter counts measured from the analog input channel.

Table C-6. Configuration Parameters (Left).

User Address	NvName	Field Name	Engineering Units: English (Metric) or States plus Range	Digital State or Value of State	Default
	nciDeviceName				ASCII Blanks
	nciAppVer	application_type	0 to 255		0
	nciAppVer	version_no	0 to 255		0
	nciAppVer	time	Seconds		0
FanMode	nciConfig	FanMode	AUTO_FAN CONTINUOUS_FAN	0 1	AUTO_FAN
EconMode	nciConfig	EconEnable	DIGITAL_IN OD_TEMP OD_ENTH_A_TYPE OD_ENTH_B_TYPE OD_ENTH_C_TYPE OD_ENTH_D_TYPE DIFF_TEMP SINGLE_ENTH DIFF_ENTH ECON_NUL	0 1 2 3 4 5 6 7 8 255	ECON_NUL

Table C-6. Configuration Parameters (Right).

E-Vision (EV): Calibrate (C), Monitor (M), Parameter (P), Schematic (S) Share (SH), Map (MA), Direct Access (DA) Hardware Configuration (HW), Manual Configuration (MN), Test (TS)							NOTE: Physical I/O points that are configurable are in Table 1.
EV	SH	MA	DA	HW	MN	TS	Comments
							DeviceName is an 18 character field used to identify the node uniquely as one object at the site or project. The contents of the DeviceName is maintained by a management node. If DeviceName is all ASCII blanks, it is considered unconfigured.
							ApplicationType identifies the current application number of the Excel 10.
							VersionNumber identifies the version number of the Excel 10 application.
							The time stamp of the last change to the Excel 10 application configuration. Time meets the ANSI C time stamp requirement specifying the number of seconds elapsed since midnight (0:00:00), January 1, 1970. It is represented in the Intel Format.
P		X	X				FanMode specifies the operation of the fan. If the FanMode is 0 (AUTO_FAN), then the fan cycles on and off with demand for cooling and may cycle with heating if FanOnHeat is TRUE. If the FanMode is 1 (CONTINUOUS_FAN), then the fan runs continuously when the effective occupancy is OC_OCCUPIED or OC_BYPASS. The fan cycles on and off with demand for cooling and may cycle with heating if FanOnHeat is TRUE during the OC_UNOCCUPIED or OC_STANDBY modes.
P		X	X				EconEnable specifies the method used to determine when outside air is suitable for use to augment cooling. The valid values are according to the enumerated list that is shown in the Engineering Units/States column.

(continued)

Table C-6. Configuration Parameters (Left Continued).

User Address	NvName	Field Name	Engineering Units: English (Metric) or States plus Range	Digital State or Value of State	Default
SmkCtlMode	nciConfig	SmokeControl	FAN_OFF_DAMPER_CLOSED FAN_ON_DAMPER_OPEN FAN_ON_DAMPER_CLOSED	0 1 2	FAN_OFF_DAMPER_CL OSED
HeatCycHr	nciConfig	ubHeatCph	2 to 12		6
CoolCycHr	nciConfig	ubCoolCph	2 to 12		3
FanRunOnCool	nciConfig	ubFanRunonCoolS0	Seconds 0 to 120		0
FanRunOnHeat	nciConfig	ubFanRunonHeatS0	Seconds 0 to 120		0
EconMtrSpd	nciConfig	ubEconMtrTimeS0	Seconds 20 to 240		90
CoolMtrSpd	nciConfig	ubCoolMtrTimeS0	Seconds 20 to 240		90
HeatMtrSpd	nciConfig	ubHeatMtrTimeS0	Seconds 20 to 240		90
FanFailTime	nciConfig	ubFanFailTimeS0	Seconds 1 to 20		10
RmTempCal	nciConfig	siSpaceTempZeroCalS7	Degrees F -5 to 5 (-3 to 3)		0
TempOffstCal1	nciConfig	siResistiveOffsetCalS7[0]	Degrees F -15 to 15 (-9 to 9)		0

Table C-6. Configuration Parameters (Right Continued).

E-Vision (EV): Calibrate (C), Monitor (M), Parameter (P), Schematic (S) Share (SH), Map (MA), Direct Access (DA) Hardware Configuration (HW), Manual Configuration (MN), Test (TS)							Comments
EV	SH	MA	DA	HW	MN	TS	
P		X	X				SmokeControl specifies the operation of the economizer damper and the fan when the mode is SMOKE_EMERGENCY.
P		X	X				HeatCph specifies the mid-load number of on/off cycles per hour when the mode is HEAT. In addition the cycle rate specifies the minimum on and off time. Refer to Table B-3 Interstage Minimum Times of the System Engineering Guide for the actual values.
P		X	X				CoolCph specifies the mid-load number of on/off cycles per hour when the mode is COOL. In addition the cycle rate specifies the minimum on and off time. Refer to Table B-3 Interstage Minimum Times of the System Engineering Guide for the actual values.
P		X	X				FanRunonCool specifies how long the fan runs after all the cooling stages have turned off. The fan is turned off FanRunonCool seconds after all the cooling demand has turned off.
P		X	X				FanRunonHeat specifies how long the fan runs after all the heating stages have turned off. The fan is turned off FanRunonHeat seconds after all the heating demand has turned off.
P		X	X				EconMtrTime specifies how long it takes the economizer damper motor to travel from fully closed to fully open. This time is used to calculate the reported position of the damper and to determine the length of over drive time required to assure the damper is fully closed or open.
P		X	X				CoolMtrTime specifies how long it takes the cooling damper or valve motor to travel from fully closed to fully open. This time is used to calculate the reported position of the cooling damper or valve and to determine the length of over drive time required to assure that it is fully closed or open.
P		X	X				HeatMtrTime specifies how long it takes the heating damper or valve motor to travel from fully closed to fully open. This time is used to calculate the reported position of the heating damper or valve and to determine the length of over drive time required to assure that it is fully closed or open.
P		X	X				Each time FAN_OUT is energized, then the node waits for FanFailTime seconds to sample the ProofAirFlow input. If ProofAirFlow shows that the fan is not running for FanFailTime consecutive seconds, then the control is shut down for the minimum off time. Then the control (including the fan) is restarted and ProofAirFlow is again tested. If ProofAirFlow shows air flow, then the control continues to operate, but if ProofAirFlow fails to show air flow, then the control is again shut down for the minimum off time. After three unsuccessful restarts, a LOSS_OF_AIR_FLOW alarm is issued and the control stays in the DISABLED mode with the FAN_OUT off.
		X	X				SpaceTempZeroCal provides offset calibration for the space analog sensor input and is added to the sensed value. The range of SpaceTempZeroCal is between -5 and 5 degrees F.
							ResistiveOffsetCal[0] provides offset calibration for the resistive analog sensor input and is added to the sensed value. The range of ResistiveOffsetCal[0] is between -15 and 15 degrees F.

(continued)

Table C-6. Configuration Parameters (Left Continued).

User Address	NvName	Field Name	Engineering Units: English (Metric) or States plus Range	Digital State or Value of State	Default
TempOffstCal2	nciConfig	siResistiveOffsetCalS7[1]	Degrees F -15 to 15 ( -9 to 9)		0
VoltOffstCal1	nciConfig	siVoltageOffsetCalS12[0]	volts -1 to 1		0
VoltOffstCal2	nciConfig	siVoltageOffsetCalS12[1]	volts -1 to 1		0
FanOnHtMode	nciConfig	FanOnHeat	FALSE TRUE	0 1	TRUE
DisMinHtTime	nciConfig	DisableHeatMinTime	FALSE TRUE	0 1	FALSE
DisMinCITime	nciConfig	DisableCoolMinTime	FALSE	0 1	FALSE
CascCntrl	nciConfig	CascadeControl	FALSE TRUE	0 1	FALSE
UseRaTempCtl	nciConfig	ControlUsesRtnAirTemp	FALSE TRUE	0 1	FALSE
laqUseHeat	nciConfig	laqUseHeat	FALSE TRUE	0 1	FALSE

Table C-6. Configuration Parameters (Right Continued).

E-Vision (EV): Calibrate (C), Monitor (M), Parameter (P), Schematic (S) Share (SH), Map (MA), Direct Access (DA) Hardware Configuration (HW), Manual Configuration (MN), Test (TS)							Comments
EV	SH	MA	DA	HW	MN	TS	
							NOTE: Physical I/O points that are configurable are in Table 1.
							ResistiveOffsetCal[1] provides offset calibration for the resistive analog sensor input and is added to the sensed value. The range of ResistiveOffsetCal[1] is between -15 and 15 degrees F.
							VoltageOffsetCal[0] provides offset calibration for the voltage/current analog sensor input and is added to the sensed value. The current analog sensor is converted to a voltage by a 249 ohm resistor wired across the input terminals. The range of VoltageOffsetCal[0] is between -1 and 1 volt. Voltage offsets are new in engineering units (not volts).
							VoltageOffsetCal[1] provides offset calibration for the voltage/current analog sensor input and is added to the sensed value. The current analog sensor is converted to a voltage by a 249 ohm resistor wired across the input terminals. The range of VoltageOffsetCal[1] is between -1 and 1 volt. Voltage offsets are new in engineering units (not volts).
P		X	X				FanOnHeat specifies the operation of the fan during HEAT mode. If FanOnHeat is 1(TRUE), then the fan is on when the mode is HEAT. If FanOnHeat is a 0 (FALSE) the fan is never turned on when the mode is HEAT, and typically a thermostatically controlled switch sensing heated air temperature turns on the fan.
P		X	X				If DisableHeatMinTime is 0 (FALSE), the heating stages are on or off for a minimum time determined by ubHeatCph (Refer to Table B-3 Interstage Minimum Times of the System Engineering Guide). If DisableHeatMinTime is 1 (TRUE), the heating stages are on or off for a 30 second minimum time.
P		X	X				If DisableCoolMinTime is 0 (FALSE), the cooling stages are on or off for a minimum time determined by CoolCph (Refer to Table B-3 Interstage Minimum Times of the System Engineering Guide). If DisableCoolMinTime is 1 (TRUE), the cooling stages are on or off for a 30 second minimum time.
P		X	X				When CascadeControl is 0 (FALSE), then the discharge air temperature is not directly controlled and heating and cooling equipment are modulated to maintain space temperature. When CascadeControl is 1 (TRUE), then the discharge air temperature is controlled by an additional control loop based on the error signal from the space temperature control loop. Cascade Control is applicable to modulating heating/cooling only (not staged).
P		X	X				If ControlUsesRtnAirTemp is a 0 (FALSE), then Data2.SpaceTemp is set equal either the space temperature sensor (IO.siSpaceTemp) or SpaceTemp depending on the value of SpaceTemp. When ControlUsesRtnAirTemp is 1 (TRUE) and SpaceTemp is SI_INVALID, then Data2.SpaceTemp is set equal to return air sensor (IO.ReturnTemp) and the control uses the return air sensor to control heating or cooling. When ControlUsesRtnAirTemp is 1 (TRUE) and SpaceTemp is not SI_INVALID, then Data2.siSpaceTemp is set equal to SpaceTemp and the control uses SpaceTemp to control heating or cooling.
P		X	X				When the effective occupancy is OC_OCCUPIED and laqUseHeat is 0 (FALSE), then no heating stages or modulating heating are turned when the discharge air temperature goes below the low limit. Energy has priority over ventilation. When the effective occupancy is OC_OCCUPIED and laqUseHeat is 1 (TRUE), then the heating stages or modulating heating are turned on to prevent the discharge air temperature from going below the discharge air temperature low limit. Ventilation has priority over energy cost.

(continued)

Table C-6. Configuration Parameters (Left Continued).

User Address	NvName	Field Name	Engineering Units: English (Metric) or States plus Range	Digital State or Value of State	Default
OvrdPriority	nciConfig	OverridePriority	LAST NET	0 1	NET
UseWallModStpt	nciConfig	UseWallModStPt	FALSE TRUE	0 1	FALSE
SetPtKnob	nciConfig	SetPntKnob	OFFSET ABSOLUTE_MIDDLE	0 1	ABSOLUTE_MIDDLE
OvrdType	nciConfig	OverrideType	NONE NORMAL BYPASS_ONLY	0 1 2	NORMAL

Table C-6. Configuration Parameters (Right Continued).

E-Vision (EV): Calibrate (C), Monitor (M), Parameter (P), Schematic (S) Share (SH), Map (MA), Direct Access (DA) Hardware Configuration (HW), Manual Configuration (MN), Test (TS)							NOTE: Physical I/O points that are configurable are in Table 1.
EV	SH	MA	DA	HW	MN	TS	Comments
P		X	X				OverridePriority configures the override arbitration between ManOcc, Bypass.state, and the wall module override button. If OverridePriority is 0 (LAST), then the last command received from either the wall module or iManOcc determines the effective override state. If OverridePriority is 1 (NET), this specifies that when ManOcc is not OC_NUL, that the effective occupancy is ManOcc regardless of the wall module override state.
P		X	X				UseWallModStPt specifies the OC_OCCUPIED temperature setpoint source. If UseWallModStPt is 0 (FALSE), then the occupied TempSetPts are used when the effective occupancy is OC_OCCUPIED. If UseWallModStPt is 1 (TRUE), then the wall modules setpoint knob is used when the effective occupancy is OC_OCCUPIED. SetPt overrides all.
P		X	X				SetPntKnob specifies the usage of the setpoint knob when UseWallModStPt is TRUE. When SetPntKnob is 0 (ABSOLUTE_MIDDLE), the setpoint knob directly determines the center point of between the OC_OCCUPIED cooling and heating setpoints. When SetPntKnob is 1 (OFFSET), the effective setpoint is calculated by adding the remote setpoint potentiometer value (center scale = 0) to the appropriate value of TempSetPts.
P		X	X				OverrideType specifies the behavior of the override button. If the OverrideType is 0 (NONE) then the override button is disabled. An OverrideType of 1 (NORMAL), causes the override button to set the OverRide state to OC_BYPASS for Aux2SetPt.BypassTime seconds when the override button has been pressed for approximately 1 to 4 seconds, or to set the OverRide state to UNOCC when the button has been pressed for approximately 4 to 7 seconds. When the button is pressed longer than approximately 7 seconds, then the OverRide state is set to OC_NUL. If the OverrideType is 2 (BYPASS_ONLY), the override button sets the OverRide state to OC_BYPASS for Aux2SetPt.BypassTime seconds on the first press. On the next press, the OverRide state is set to OC_NUL.

Table C-7. LonMark®/Open System Points (Left).

User Address	NvName	Field Name	Engineering Units: English (Metric) or States plus Range	Digital State or Value of State	Default
	nciNodeSendT (SNVT_time_sec)		Seconds		0
	nciRtuSendT (SNVT_time_sec)		Seconds		0
	nciRtuRcvT (SNVT_time_sec)		Seconds		0
CoolOccSpt	nciTempSetPts (SNVT_temp_setpt)	occupied_cool	Degrees F 50 to 95 Degrees C (10 to 35)		23
CoolStbySpt	nciTempSetPts (SNVT_temp_setpt)	standby_cool	Degrees F 50 to 95 Degrees C (10 to 35)		25
CoolUnoccSpt	nciTempSetPts (SNVT_temp_setpt)	unoccupied_cool	Degrees F 50 to 95 (10 to 35)		28
HeatOccSpt	nciTempSetPts (SNVT_temp_setpt)	occupied_heat	Degrees F 50 to 95 Degrees C (10 to 35)		21
HeatStbySpt	nciTempSetPts (SNVT_temp_setpt)	standby_heat	Degrees F 50 to 95 Degrees C (10 to 35)		19
HeatUnoccSpt	nciTempSetPts (SNVT_temp_setpt)	unoccupied_heat	Degrees F 50 to 95 (10 to 35)		16
	nviRequest (SNVT_obj_request)	object_id	0 to 65535		1

Table C-7. LonMark®/Open System Points (Right).

E-Vision (EV): Calibrate (C), Monitor (M), Parameter (P), Schematic (S) Share (SH), Map (MA), Direct Access (DA) Hardware Configuration (HW), Manual Configuration (MN), Test (TS)							Comments
EV	SH	MA	DA	HW	MN	TS	
							The maximum time between updates of network variable outputs from the node object.
							The SGPUC and SGPU time (heart beat time) between updates of network variable outputs. NOTE: RtuSendT should be set to 55 seconds by a management node to be compatible with a Honeywell system.
							This is the failure detection time for network SGPUC and SGPU variables outputs. NOTE: RtuRcvT should be set to 300 seconds by a management node to be compatible with a Honeywell system.
P, M		X	X				The Cooling Occupied Setpoint is used if no wall module setpoint pot is configured as the standard Occupied Cooling Setpoint. Actual Cooling Setpoint can be affected by various control parameters (such as DlcShed, SrcRmtTempSpt, etc). Actual room temperature Setpoint is reflected in RmTempActSpt. Overriden by nviSetPt. Used to compute ZEB.
P, M		X	X				When the controller is in the Standby mode (typically via an occupancy sensor), the base Cooling Setpoint is determined by the Cooling Standby Setpoint value. Also, when a wall module setpoint pot is configured, this value serves as the upper limit on the user adjustable remote setpoint pot (wall module).
P, M		X	X				When the controller is in the Unoccupied mode, the unit responds to a call for cooling based on the Cooling Unoccupied Setpoint.
P, M		X	X				When the controller is in the Occupied mode, if the space temperature drops below the Heating Occupied Setpoint, the unit switches to the Heating mode. This Setpoint is used only when there is no wall module setpoint pot configured. Overriden by nviSetPt. Used to compute ZEB.
P, M		X	X				When the controller is in the Standby mode (typically via an occupancy sensor), the base Heating Setpoint is determined by the Heating Standby Setpoint value. Also, when a wall module setpoint pot is configured, this value serves as the lower limit on the user adjustable remote setpoint pot (wall module).
P, M		X	X				When the controller is in the Unoccupied mode, the unit responds to a call for heating based on the Heating Unoccupied Setpoint.
							Request provides the mechanism to request a particular status report (via Status) for a particular object within this node. Object_id selects the object being referenced by nviRequest. The only valid value of object_id is 1 for the RTU object and all others are invalid.

(continued)

Table C-7. LonMark®/Open System Points (Left Continued).

User Address	NvName	Field Name	Engineering Units: English (Metric) or States plus Range	Digital State or Value of State	Default
	nviRequest (SNVT_obj_request)	object_request	RQ_NORMAL RQ_DISABLED RQ_UPDATE_STATUS RQ_SELF_TEST RQ_UPDATE_ALARM RQ_REPORT_MASK RQ_OVERRIDE RQ_ENABLE RQ_RMV_OVERRIDE RQ_CLEAR_ATATUS RQ_CLEAR_ALARM RQ_NUL	0 1 2 3 4 5 6 7 8 9 10 255	RQ_NORMAL
DestHvacMode	nviApplMode (SNVT_hvac_mode)		HVAC_AUTO HVAC_HEAT HVAC_MRNG_WRMUP HVAC_COOL HVAC_NIGHT_PURGE HVAC_PRE_COOL HVAC_OFF HVAC_TEST HVAC_EMERG_HEAT HVAC_FAN_ONLY HVAC_NUL	0 1 2 3 4 5 6 7 8 9 255	HVAC_AUTO
DestManualOcc	nviManOcc (SNVT_occupancy)		OC_OCCUPIED OC_UNOCCUPIED OC_BYPASS OC_STANDBY OC_NUL	0 1 2 3 255	OC_NUL
DestRmTempSpt	nviSetPoint (SNVT_temp_p)		Degrees F 50 to 95 Degrees C (10 to 35)		SI_INVALID
DestSptOffset	nviSetPtOffset (SNVT_temp_p)		Degrees F -18 to 18 Degrees C -10 to 10		0
SrcRmTempActSpt	nvoEffectSetPt (SNVT_temp_p)		Degrees F 50 to 95 Degrees C (10 to 35)		SI_INVALID

Table C-7. LonMark®/Open System Points (Right Continued).

E-Vision (EV): Calibrate (C), Monitor (M), Parameter (P), Schematic (S) Share (SH), Map (MA), Direct Access (DA) Hardware Configuration (HW), Manual Configuration (MN), Test (TS)							Comments
EV	SH	MA	DA	HW	MN	TS	
							When object_request is RQ_NORMAL or RQ_UPDATE_STATUS then the status (via Status) will be reported for the object addressed by object_id. When object_request is RQ_REPORT_MASK then the status bits will be reported that are supported in nvoStatus by the object addressed by object_id. Bits that are supported by the object are set to one. All other object_request items are not supported at this time and will return an invalid_request (Status) in the object status.
M	X	X	X		X		ApplMode is an input that coordinates the roof top unit controller operation with other controllers. HVAC_NIGHT_PURGE HVAC_PRE_COOL HVAC_MRNG_WRMUP HVAC_NUL HVAC_TEST are not supported and will default to the HVAC_AUTO setting if received.
	X		X		X		ManOcc is an input from a network connected operator interface or other node that indicates the state of a manual occupancy control thus over riding the scheduled occupancy state. ManOcc is used along with other occupancy inputs to calculate the effective occupancy of the node. See the Data1.EffectOcc and Data1.NetManOcc for more details. The valid enumerated values have the following meanings: OC_OCCUPIED indicates occupied. OC_UNOCCUPIED indicates not occupied. OC_BYPASS indicates that the space is occupied for Aux2SetPt.BypassTime seconds after ManOcc is first set to OC_BYPASS. The timing is done by the bypass timer in this node. If ManOcc changes to another value the timer is stopped. OC_STANDBY indicates that the space is in standby mode. OC_NUL and all unspecified values means that no manual occupancy control is requested. When ManOcc changes from OC_OCCUPIED, OC_UNOCCUPIED, OC_BYPASS, or OC_STANDBY to OC_NUL, any bypass condition is canceled.
	X		X		X		SetPoint is an input network variable used to determine the temperature control point of the node. If SetPoint is not SI_INVALID, then it is used to determine the control point of the node. If SetPoint is SI_INVALID, then other means are used to determine the control point. See Data2.TempControlPt for more information.
	X		X		X		SetPtOffset is input from an operator terminal or from an energy management system used to shift the effective temperature setpoint by adding SetPtOffset to the otherwise calculated setpoint. If the value is outside the allowed range of -10 to +10 degrees C (-18 to 18 degrees F), then the node uses the value of the nearest range limit.
	X		X				EffectSetPt is the current temperature control point (such that the current actual space temperature setpoint which the controller is presently trying to maintain in the conditioned space). See Data2.TempControlPt for more details. EffectSetPt is updated according to the SGPU mechanism where a significant change is plus or minus 0.07 degrees C (0.13 degrees F).

(continued)

Table C-7. LonMark®/Open System Points (Left Continued).

User Address	NvName	Field Name	Engineering Units: English (Metric) or States plus Range	Digital State or Value of State	Default
DestRmTemp	nviSpaceTemp (SNVT_temp_p)		Degrees F 14 to 122 Degrees C (-10 to 50)		SI_INVALID
SrcRmTemp	nvoSpaceTemp (SNVT_temp_p)		Degrees F 14 to 122 Degrees C (-10 to 50)		SI_INVALID
DestOaTemp	nviOdTemp (SNVT_temp_p)		Degrees F -40 to 122 Degrees C (-40 to 50)		SI_INVALID
SrcOaTemp	nvoOdTemp (SNVT_temp_p)		Degrees F -40 to 122 Degrees C (-40 to 50)		SI_INVALID
DestOaHum	nviOdHum (SNVT_lev_percent)		Percentage 10 to 90		SI_INVALID
SrcOaHum	nvoOdHum (SNVT_lev_percent)		Percentage 10 to 90		SI_INVALID
DestEmergCmd	nviEmerg (SNVT_hvac_emerg)		EMERG_NORMAL EMERG_PRESSURIZE EMERG_DEPRESSURIZE EMERG_PURGE EMERG_SHUTDOWN EMERG_NUL	0 1 2 3 4 255	EMERG_NORMAL

Table C-7. LonMark®/Open System Points (Right Continued).

E-Vision (EV): Calibrate (C), Monitor (M), Parameter (P), Schematic (S) Share (SH), Map (MA), Direct Access (DA) Hardware Configuration (HW), Manual Configuration (MN), Test (TS)							Comments
EV	SH	MA	DA	HW	MN	TS	
	X		X		X		SpaceTemp is the space temperature sensed by another node and is typically bound to SpaceTemp of another node having a space temperature sensor. If SpaceTemp has a value other than SI_INVALID it is used as the sensed space temperature by the node rather than using any local hardwired sensor. If the value is outside the allowed range of -10 to 50 degrees C (-18 to 90 degrees F), then the node uses the value of the nearest range limit. When SpaceTemp is not bound to another node, SpaceTemp may be used to fix the sensed temperature. A management node may write a value other than SI_INVALID, causing the node to use SpaceTemp instead of the hardwired sensor. An application restart or power failure causes the fixed sensor value to be forgotten and SpaceTemp to be returned to SI_INVALID.
	X		X				SpaceTemp is the sensed space temperature from the locally wired sensor. SpaceTemp is typically bound to SpaceTemp of another node which may not have its own space temperature sensor but control the same space. The reported space temperature includes the offset correction Config.SpaceTempZeroCal. If the space temperature sensor is not connected or is shorted, or if SpaceTemp is bound to another node, then SpaceTemp is set to SI_INVALID.
M	X		X		X		OdTemp allows one outside air temperature sensor at a node to be shared by many other nodes. When OdTemp is not SI_INVALID, then any local sensor is ignored by the local control algorithm and OdTemp is used instead. If the value is outside the allowed range of -40 to 50 degrees C (-72 to 90 degrees F), then the node uses the value of the nearest range limit.
M	X		X				OdTemp allows the local outdoor temperature sensor to be shared with other nodes and is typically bound to OdTemp on other nodes. If the local sensor is configured by Select, OdTemp is periodically sent on the network. If the local sensor is not configured or currently showing an error, the value is SI_INVALID.
M	X		X		X		OdHum allows one outdoor humidity sensor at a node to be shared by many other nodes. When nviOdHum is not SI_INVALID, then the local sensor, is ignored by the local control algorithm and OdHum is used instead. If the value is outside the allowed range (10 to 90 percent), then the node uses the value of the nearest range limit.
M	X		X				OdHum allows the local outdoor humidity sensor to be shared with other nodes and is typically bound to OdHum on other nodes. If the local sensor is configured by Select, OdHum is periodically sent on the network. If the local sensor is not configured or currently showing an error, the value is SI_INVALID.
M	X	X	X		X		Emerg is an emergency input from a device that determines the correct action during a given emergency (such as a fire). If Emerg is EMERG_NORMAL the fan and economizer damper are controlled by the heating and cooling control algorithm. If Emerg is EMERG_PRESSURIZE, then the fan is controlled on and the economizer damper is open. If Emerg is EMERG_DEPRESSURIZE, then the fan is controlled on and the economizer damper is closed. If Emerg is EMERG_SHUTDOWN, then the fan is controlled off and the economizer damper is closed. If Emerg is EMERG_PURGE, the fan and damper go to the state specified by Config.SmokeControl. If Emerg is not configured then it is set to EMERG_NUL.

(continued)

Table C-7. LonMark®/Open System Points (Left Continued).

User Address	NvName	Field Name	Engineering Units: English (Metric) or States plus Range	Digital State or Value of State	Default
SrcUnitStatus	nvoUnitStatus (SNVT_hvac_status)	mode	HVAC_AUTO HVAC_HEAT HVAC_MRNG_WRMUP HVAC_COOL HVAC_NIGHT_PURGE HVAC_PRE_COOL HVAC_OFF HVAC_TEST HVAC_EMERG_HEAT HVAC_FAN_ONLY HVAC_NUL	0 1 2 3 4 5 6 7 8 9 255	HVAC_NUL
	nvoUnitStatus (SNVT_hvac_status)	heat_output_primary	Percentage 0 to 100		0
	nvoUnitStatus (SNVT_hvac_status)	heat_output_secondary	Percentage 0 to 100		0
	nvoUnitStatus (SNVT_hvac_status)	cool_output	Percentage 0 to 100		0
	nvoUnitStatus (SNVT_hvac_status)	econ_output	Percentage 0 to 100		0
	nvoUnitStatus (SNVT_hvac_status)	fan_output	Percentage 0 to 100		0
	nvoUnitStatus (SNVT_hvac_status)	in_alarm	FALSE TRUE ALARM_NOTIFY_DISAB LED	0 1 255	FALSE

Table C-7. LonMark®/Open System Points (Right Continued).

E-Vision (EV): Calibrate (C), Monitor (M), Parameter (P), Schematic (S) Share (SH), Map (MA), Direct Access (DA) Hardware Configuration (HW), Manual Configuration (MN), Test (TS)							Comments
EV	SH	MA	DA	HW	MN	TS	
M	X		X				<p>Mode is set according to the Data1.mode.</p> <p>If Data1.mode is START_UP_WAIT, SMOKE_EMERGENCY, or FREEZE_PROTECT, mode is set to HVAC_NUL which indicates that the node is in a mode not supported by the SNVT_hvac_mode data type.</p> <p>If Data1.mode is HEAT, then mode is set to HVAC_HEAT which indicates that heating energy is being supplied to the controlled space.</p> <p>If Data1.mode is COOL, then mode is set to HVAC_COOL, which indicates that cooling energy is being supplied to the controlled space.</p> <p>If Data1.mode is OFF_MODE or DISABLED_MODE, then mode is set to HVAC_OFF which indicates that the node is not running its normal temperature control and the outputs are not turned off.</p> <p>If Data1.mode is EMERG_HEAT, mode is set to HVAC_EMERG_HEAT where, in a heat pump application, the compressor stages are disabled and only auxiliary heating stages are turned on.</p> <p>If Data1.mode is MANUAL or FACTORY_TEST, mode is set to HVAC_TEST which indicates that the node is in a manual or test mode.</p> <p>If Data1.mode is FAN_ONLY, mode is set to HVAC_FAN_ONLY which indicates that the fan is running but the space temperature control is turned off.</p>
							heat_output_primary reports the current percentage of heating stages or modulating heat turned on. If the node is controlling a heat pump, heat_output_primary reports the current percentage of compressor stages turned on when the node is in the HVAC_HEAT mode.
							If the node is controlling a heat pump, heat_output_secondary reports the current percentage of auxiliary heating stages turned on when the node is in the HVAC_HEAT or HVAC_EMERG_HEAT mode. If the node is not controlling a heat pump, heat_output_secondary is set to zero.
							cool_output reports the current percentage of cooling stages or modulating cool turned on. If the node is controlling a heat pump, cool_output reports the current percentage of compressor stages turned on when the node is in the HVAC_COOL mode.
							If there is a modulating economizer configured, econ_output reports the percentage that the economizer damper is opened. If no economizer is configured, econ_output reports 0.
							When the fan is running, fan_output is 100 percent, and when the fan is not running, fan_output is 0 percent.
							When there is an alarm reported by AlarmStatus, then in_alarm is set to 1 (TRUE), else in_alarm is set to 0 (FALSE). If alarms reporting is suppressed via ManualMode, then in_alarm is set to ALARM_NOTIFY_DISABLED.

(continued)

Table C-7. LonMark®/Open System Points (Left Continued).

User Address	NvName	Field Name	Engineering Units: English (Metric) or States plus Range	Digital State or Value of State	Default
	nvinUse (unsigned long)		0 To 65535		0 to FFFF
	nvoStatus (SNVT_obj_request)	object_id	0 to 65535		0
	nvoStatus (SNVT_obj_request)	invalid_id	FALSE TRUE	0 1	FALSE
	nvoStatus (SNVT_obj_request)	invalid_request	FALSE TRUE	0 1	FALSE
	nvoStatus (SNVT_obj_request)	disabled	FALSE TRUE	0 1	FALSE
	nvoStatus (SNVT_obj_request)	out_of_limits	FALSE TRUE	0 1	FALSE
	nvoStatus (SNVT_obj_request)	open_circuit	FALSE TRUE	0 1	FALSE
	nvoStatus (SNVT_obj_request)	out_of_service	FALSE TRUE	0 1	FALSE
	nvoStatus (SNVT_obj_request)	mechanical_fault	FALSE TRUE	0 1	FALSE
	nvoStatus (SNVT_obj_request)	feedback_failure	FALSE TRUE	0 1	FALSE
	nvoStatus (SNVT_obj_request)	over_range	FALSE TRUE	0 1	FALSE

Table C-7. LonMark®/Open System Points (Right Continued).

E-Vision (EV): Calibrate (C), Monitor (M), Parameter (P), Schematic (S) Share (SH), Map (MA), Direct Access (DA) Hardware Configuration (HW), Manual Configuration (MN), Test (TS)							Comments
EV	SH	MA	DA	HW	MN	TS	
							InUse is used by a management node to indicate to all other management nodes that it is logged on to the Excel 10 node and that they should not try to interact with any of the Excel 10s network variables. Before the management node reads or writes any network variables, the management node checks nviInUse for a zero value meaning no other management nodes are already logged on and that a management node may log on to the node. Then the management node writes a number, 1 through 65534, to nviInUse and periodically writes the same value to indicate that the management node is still logged on. If there are no writes made to nviInUse for approximately 60 seconds, then the Excel 10 resets nviInUse to zero to automatically log off the management node. Before interacting with any network variables, the management node verifies that the nviInUse has not changed. The management node logs off by writing 0 to nviInUse. During power up, an application restart, or return to on-line from off-line, the Excel 10 sets InUse to 65535 to indicate to the management node that it has returned to on-line.
M			X				object_id is set to the current value of nviRequest.object_id
							If Request.Object_id is not a valid object, invalid_id is set to 1 (TRUE) otherwise it is set to 0 (FALSE).
							If Request.object_request is not a valid request for the object addressed, invalid_request is set to 1 (TRUE) otherwise it is set to 0 (FALSE).
							The disabled field is not supported and is set to 0 (FALSE) unless Request.object_request is RQ_REPORT_MASK, then disabled and in_alarm are set to 1 (TRUE) to indicate that these functions are supported while all other fields are set to 0 (FALSE).
							The out_of_limits field is not supported and is set to 0 (FALSE).
							The open_circuit field is not supported and is set to 0 (FALSE).
							The out_of_service field is not supported and is set to 0 (FALSE).
							The mechanical_fault field is not supported and is set to 0 (FALSE).
							The feedback_failure field is not supported and is set to 0 (FALSE).
							The over_range field is not supported and is set to 0 (FALSE).

(continued)

Table C-7. LonMark®/Open System Points (Left Continued).

User Address	NvName	Field Name	Engineering Units: English (Metric) or States plus Range	Digital State or Value of State	Default
	nvoStatus (SNVT_obj_request)	under_range	FALSE TRUE	0 1	FALSE
	nvoStatus (SNVT_obj_request)	electrical_fault	FALSE TRUE	0 1	FALSE
	nvoStatus (SNVT_obj_request)	unable_to_measure	FALSE TRUE	0 1	FALSE
	nvoStatus (SNVT_obj_request)	comm_failure	FALSE TRUE	0 1	FALSE
	nvoStatus (SNVT_obj_request)	fail_self_test	FALSE TRUE	0 1	FALSE
	nvoStatus (SNVT_obj_request)	self_test_in_progress	FALSE TRUE	0 1	FALSE
	nvoStatus (SNVT_obj_request)	locked_out	FALSE TRUE	0 1	FALSE
	nvoStatus (SNVT_obj_request)	manual_control	FALSE TRUE	0 1	FALSE
	nvoStatus (SNVT_obj_request)	in_alarm	FALSE TRUE	0 1	FALSE
	nvoStatus (SNVT_obj_request)	in_override	FALSE TRUE	0 1	FALSE
DestOccSensor	nviSensorOcc (SNVT_occupancy)		OC_OCCUPIED OC_UNOCCUPIED OC_BYPASS OC_STANDBY OC_NUL	0 1 2 3 255	OC_NUL
SrcOccSensor	nvoSensorOcc (SNVT_occupancy)		OC_OCCUPIED OC_UNOCCUPIED OC_BYPASS OC_STANDBY OC_NUL	0 1 2 3 255	OC_NUL

Table C-7. LonMark®/Open System Points (Right Continued).

E-Vision (EV): Calibrate (C), Monitor (M), Parameter (P), Schematic (S) Share (SH), Map (MA), Direct Access (DA) Hardware Configuration (HW), Manual Configuration (MN), Test (TS)							Comments
EV	SH	MA	DA	HW	MN	TS	
							The under_range field is not supported and is set to 0 (FALSE).
							The electrical_fault field is not supported and is set to 0 (FALSE).
							The unable_to_measure field is not supported and is set to 0 (FALSE).
							The comm_failure field is not supported and is set to 0 (FALSE).
							The fail_self_test field is not supported and is set to 0 (FALSE).
							The self_test_in_progress field is not supported and is set to 0 (FALSE).
							The locked_out field is not supported and is set to 0 (FALSE).
							The manual_control field is not supported and is set to 0 (FALSE).
							If there are currently any active alarms reported by SrcUnitStatus.in_alarm or SrcUnitStatus.in_alarm is set to ALARM_NOTIFY_DISABLED, in_alarm is set to 1 (TRUE), otherwise in_alarm is set to 0 (FALSE). When Request.object_request is RQ_REPORT_MASK, then disabled and in_alarm are set to 1 (TRUE) to indicate that these functions are supported while all other fields are set to 0 (FALSE).
							The in_override field is not supported and is set to 0 (FALSE).
M	X		X		X		nviSensorOcc allows an occupancy sensor at another node to be used as the occupancy sensor for this node and is typically bound to SensorOcc of another node. The nviSensorOcc input must show OC_UNOCCUPIED for 300 seconds before it is used by the controller for triggering UN_OC operation. This makes it possible for several occupancy sensors to be ORed together by binding them all to nviSensorOcc. If any one bound occupancy sensor shows occupancy, then SensorOcc shows occupancy for up to 300 seconds after the last sensor shows OC_OCCUPIED. The valid states have the following meanings: OC_OCCUPIED indicates occupied. OC_BYPASS, OC_STANDBY, and all unspecified values indicates the same as OC_OCCUPIED. OC_UNOCCUPIED or OC_NUL indicates not occupied.
M	X		X				nvoSensorOcc is an output showing the current state of the hard wired occupancy sensor. The valid states are as follows: OC_OCCUPIED indicates that the space is occupied. OC_UNOCCUPIED indicates that the space is not occupied. OC_NUL means no output is available because it is not configured.

(continued)

Table C-7. LonMark®/Open System Points (Left Continued).

User Address	NvName	Field Name	Engineering Units: English (Metric) or States plus Range	Digital State or Value of State	Default
	nviWindow (SNVT_switch)	value	0 to 100		0
DestWndw	nviWindow (SNVT_switch)	state	SW_OFF SW_ON SW_NUL	0 1 255	SW_NUL
SrcWndwCt	nvoWindow (SNVT_switch)	value	0 to 100		0
SrcWndw	nvoWindow (SNVT_switch)	state	SW_OFF SW_ON SW_NUL	0 1 255	SW_NUL
	nviEcon (SNVT_switch)	value	0 to 100		0
DestEconEnable	nviEcon (SNVT_switch)	state	SW_OFF SW_ON SW_NUL	0 1 255	SW_NUL
SrcEconEnCt	nvoEcon (SNVT_switch)	value	0 to 100		0
SrcEconEnable	nvoEcon (SNVT_switch)	state	SW_OFF SW_ON SW_NUL	0 1 255	SW_NUL

Table C-7. LonMark®/Open System Points (Right Continued).

E-Vision (EV): Calibrate (C), Monitor (M), Parameter (P), Schematic (S) Share (SH), Map (MA), Direct Access (DA) Hardware Configuration (HW), Manual Configuration (MN), Test (TS)							Comments
EV	SH	MA	DA	HW	MN	TS	
							Window allows the window sensor from another node to be used as the window sensor and is typically bound to nvoWindow of another node. Window must show that the window is closed for 300 seconds before Window is used as window closed. This makes it possible for several window sensors to be ORed together by binding them all to nviWindow. If any one bound window sensor shows window open, then Window shows window open for up to 300 seconds after the last sensor shows window closed. If the state is SW_OFF or SW_NUL, then the result is Window Closed. If the state is SW_ON and the value is 0, then the result is Window Closed. If the node receives this combination of state and value, then state is set to SW_OFF. If the state is SW_ON and the value is not zero, then the result is Window Open. NOTE: nviWindow is called nviEnergyHoldOff in the LonMark® compliance profile.
M	X		X		X		See the preceding.
	X						See the preceding. NOTE: nvoWindow is called nviEnergyHoldOff in the LonMark® compliance profile.
M	X		X				Window allows the hard wired window sensor to be used by other nodes on the network. The valid states are as follows: If the state is SW_OFF and the value is 0 then the result is Window Closed. If the state is SW_ON and the value is 100 percent, the result is Window Open. If the state is SW_NUL and the value is 0, the result is Window Sensor Not Configured. NOTE: nvoWindow is called nviEnergyHoldOff in the LonMark® compliance profile.
							nviEcon allows one controller to determine the suitability of outdoor air for free cooling and share this with many other nodes. When Econ.state is not SW_NUL, then the local sensor selected by Config.EconEnable is ignored and Econ is used instead. The inputs states have the following meanings: If the state is SW_OFF or other and the value is don't care, then the outdoor air is not suitable for free cooling. If the state is SW_ON and the value is 0, then the outdoor air is not suitable for free cooling. If the node receives this combination of state and value, then state is set to SW_OFF. If the state is SW_ON and the value is not zero, then outdoor is suitable for free cooling. If the state is SW_NUL, then the network variable is not bound, the communications path from the sending node has failed, or the sending node has failed. Outdoor air is not suitable for free cooling.
M	X		X		X		For nviEcon.state, refer to nviEcon.value.
	X						nvoEcon allows one controller to determine the suitability of outdoor air for free cooling and share this with other nodes and is typically bound to Econ on other nodes. If the economizer function is configured by Config.EconEnable, Econ is periodically calculated from the local sensor specified by Config.EconEnable and is sent on the network. Econ does not affect Econ. The output has the following states: If the state is SW_OFF and the value is 0, then the outdoor air is not suitable for free cooling. If the state is SW_ON and the value is 100 percent, then the outdoor air is suitable for free cooling. If the state is SW_NUL and the value is 0, the corresponding economizer function is not enabled because Config.EconEnable is ECON_NUL, DIFF_TEMP, or DIFF_ENTH or because the selected sensor has failed.
M	X		X				For nvoEcon.state, refer to nvoEcon.value.

Table C-8. Direct Access and Special Manual Points (Left).

User Address	NvName	Field Name	Engineering Units: English (Metric) or States plus Range	Digital State or Value of State	Default
DestManMode	nviManualMode		MODE_ENABLE MODE_DISABLE MODE_MANUAL SUPPRESS_ALARMS UNSUPPRESS_ALARMS	0 1 2 3 4	MODE_ENABLE
TestMode	nviManValue	OutDrive	NORMAL_OP OUT_1_ON OUT_2_ON OUT_3_ON OUT_4_ON OUT_5_ON OUT_6_ON OUT_7_ON OUT_8_ON ALL_OUT_OFF ALL_OUT_ON DISABLE_OUT	0 1 2 3 4 5 6 7 8 9 10 11	NORMAL_OP
TestHCPos	nviManValue	sbManHeatCoolPosS0	percentage -127 to 127		0
TestEconPos	nviManValue	sbManEconPosS0	Percentage -127 to 127		0

Table C-8. Direct Access And Special Manual Points (Right).

E-Vision (EV): Calibrate (C), Monitor (M), Parameter (P), Schematic (S) Share (SH), Map (MA), Direct Access (DA) Hardware Configuration (HW), Manual Configuration (MN), Test (TS)							Comments
EV	SH	MA	DA	HW	MN	TS	
	X	X	X				<p>ManualMode is an input which is used to disable the Excel 10s control algorithms and to manually set the physical outputs. ManualMode remains unchanged until another mode has been commanded or an application restart has been performed. See the Data1.mode for more details.</p> <p>The valid enumerated values are:</p> <p>MODE_ENABLE enables the node so that the control algorithm determines the operating mode, and controls the physical outputs. MODE_ENABLE is the default state after power restore or application restart. If the mode was MANUAL and nviManualMode is set to MODE_ENABLE, the node then goes through application_restart.</p> <p>MODE_DISABLE sets the node to the DISABLED_MODE. The alarm NODE_DISABLED is initiated, all control loops are disabled, and the physical outputs are turned off. The physical inputs, network variable inputs, and network variable outputs are still functioning when the node is in the DISABLED_MODE.</p> <p>MODE_MANUAL sets the node into the MANUAL mode. The alarm NODE_DISABLED is initiated, all control loops are disabled, and the physical outputs are controlled manually as commanded by nviManValue. The nodes configuration variables and nviManValue are used to set valves, dampers, and / or digital output to the desired manual positions or state(s). The physical inputs, network variable inputs, and network variable outputs are still functioning when the node is in the MANUAL mode.</p> <p>SUPPRESS_ALARMS causes nvoAlarm.type to be set to ALARM_NOTIFY_DISABLED, and AlarmLog to no longer record alarms. If alarms are suppressed, UNSUPPRESS_ALARMS causes Alarm.type and AlarmLog to be returned to reporting alarms. See Alarm for more details.</p> <p>All unspecified values are the same as MODE_ENABLE.</p>
							<p>OutDrive ManValue is used for Factory Testing only.</p>
						X	<p>During MANUAL mode, ManHeatCoolPos sets the modulating position of the heating or cooling motor (if configured) to the specified position. If ManHeatCoolPos is less than 0 or greater than 100, the motor is overdriven for a period longer than the motor time to ensure that it is at the end of travel. The heat motor is driven when HeatCoolMode is 1 and the cool motor is driven when HeatCoolMode is 0. At the moment when the node transfers to MANUAL_MODE or HeatCoolMode is changed, ManHeatCoolPos is set the current motor position.</p>
						X	<p>During MANUAL mode, ManEconPos sets the modulating position of the economizer motor (if configured) to the specified position. If ManEconPos is less than 0 or greater than 100, the motor is overdriven for a period longer than the motor time to ensure that it is at the end of travel. At the moment when the node transfers to MANUAL_MODE, ManEconPos is set the current motor position.</p>

(continued)

Table C-8. Direct Access And Special Manual Points (Left Continued).

User Address	NvName	Field Name	Engineering Units: English (Metric) or States plus Range	Digital State or Value of State	Default
TestHtClStg1	nviManValue	HeatCoolStage1	OFF ON	0 1	OFF
TestHtClStg2	nviManValue	HeatCoolStage2	OFF ON	0 1	OFF
TestHtClStg3	nviManValue	HeatCoolStage3	OFF ON	0 1	OFF
TestHtClStg4	nviManValue	HeatCoolStage4	OFF ON	0 1	OFF
TestAuxHt1	nviManValue	AuxHeatCoolStage1	OFF ON	0 1	OFF
TestAuxHt2	nviManValue	AuxHeatCoolStage2	OFF ON	0 1	OFF
TestAuxHt3	nviManValue	AuxHeatCoolStage3	OFF ON	0 1	OFF
TestAuxHt4	nviManValue	AuxHeatCoolStage4	OFF ON	0 1	OFF
TestHtClMode	nviManValue	HeatCoolMode	OFF ON	0 1	OFF
TestSaFan	nviManValue	FanOut	OFF ON	0 1	OFF
TestAuxEcon	nviManValue	AuxEconOut	OFF ON	0 1	OFF
TestOccStat	nviManValue	OccStatusOut	OFF ON	0 1	OFF
TestFree1	nviManValue	Free1Out	OFF ON	0 1	OFF
TestFree2	nviManValue	Free2Out	OFF ON	0 1	OFF

Table C-8. Direct Access And Special Manual Points (Right Continued).

E-Vision (EV): Calibrate (C), Monitor (M), Parameter (P), Schematic (S) Share (SH), Map (MA), Direct Access (DA) Hardware Configuration (HW), Manual Configuration (MN), Test (TS)							Comments
EV	SH	MA	DA	HW	MN	TS	
						X	During MANUAL mode, HeatCoolStage1 parameters turn the corresponding heat, or cool stage to on (1) or off (0). When HeatCoolMode is 0, then cooling loads are controlled. When HeatCoolMode is 1 and the node is controlling conventional equipment, then heating loads are controlled. When HeatCoolMode is 1 and the node is controlling a heat pump, then cooling loads are controlled.
						X	For HeatCoolStage2, refer to HeatCoolStage1.
						X	For HeatCoolStage3, refer to HeatCoolStage1.
						X	For HeatCoolStage4. refer to HeatCoolStage1.
						X	AuxHeatCoolStage1—During MANUAL mode when the node is configured to control a heat pump and HeatCoolMode is 1, these parameters turn the corresponding auxiliary heat stage on (1) or off (0).
						X	AuxHeatCoolStage2—During MANUAL mode when the node is configured to control a heat pump and HeatCoolMode is 1, these parameters turn the corresponding auxiliary heat stage on (1) or off (0).
						X	AuxHeatCoolStage3—During MANUAL mode when the node is configured to control a heat pump and HeatCoolMode is 1, these parameters turn the corresponding auxiliary heat stage on (1) or off (0).
						X	AuxHeatCoolStage4—During MANUAL mode when the node is configured to control a heat pump and HeatCoolMode is 1, these parameters turn the corresponding auxiliary heat stage on (1) or off (0).
						X	During MANUAL mode, HeatCoolMode determines whether heating or cooling outputs are turned on or off manually. When HeatCoolMode is 0, then cooling loads are controlled. When HeatCoolMode is 1 and the node is controlling conventional equipment, then heating loads are controlled. When HeatCoolMode is 1 and the node is controlling a heat pump, then cooling loads are controlled by Heat / Cool stages and heating stages are controlled by auxiliary heat stages. The CHANGE_OVER_RELAY_OUT is affected by HeatCoolMode as configured in Select.
						X	During MANUAL mode, FanOut turns the fan on (1) or off (0).
						X	During MANUAL mode, AuxEconOut turns the AUX_ECON_OUT on(1) or off(0).
						X	During MANUAL mode, OccStatusOut turns the OCCUPANCY_STATUS_OUT to on(1 = not OC_UNOCCUPIED) or off (0).
						X	During MANUAL mode, Free1Out turns the FREE1_OUT on(1) or off(0).
						X	During MANUAL mode, Free2Out turns the FREE2_OUT on(1) or off(0).

Table C-9. Data Share Points (Left).

User Address	NvName	Field Name	Engineering Units: English (Metric) or States plus Range	Digital State or Value of State	Default
DestOaEnth	nviOdEnthS7		mA 4 to 20		SI_INVALID
SrcOaEnth	nvoOdEnthS7		mA 4 to 20		SI_INVALID
SrcMonSwCt	nvoMonSw	value	0 to 100		0
SrcMonSw	nvoMonSw	state	SW_OFF SW_ON SW_NUL	0 1 255	SW_NUL

Table C-9. Data Share Points (Right).

E-Vision (EV): Calibrate (C), Monitor (M), Parameter (P), Schematic (S) Share (SH), Map (MA), Direct Access (DA) Hardware Configuration (HW), Manual Configuration (MN), Test (TS)							Comments
EV	SH	MA	DA	HW	MN	TS	
	X				X		nviOdEnth allows one outdoor enthalpy sensor at a node to be shared by many other nodes. When nviOdEnth is not SI_INVALID then any local sensor is ignored by the local control algorithm and OdEnth is used instead. If the value is outside the allowed range (4 to 20 mA), then the node uses the value of the nearest range limit.
M	X		X				nvoOdEnth allows the local outdoor enthalpy sensor to be shared with other nodes and is typically bound to OdEnth on other nodes. If the local sensor is configured by Select, nviOdEnth is periodically sent on the network. If the local sensor is not configured or currently showing an error, the value is SI_INVALID.
	X						MonSw value allows the monitor switch to be shared with another node. MonSw is typically bound to an SBC to indicate a user defined alarm condition. The output values have the following meanings: If the state is SW_OFF and the value is 0, then the monitor switch is open. If the state is SW_ON and the value is 100 percent, then the monitor switch is closed. If the state is SW_NUL and the value is 0, then the monitor switch is not configured by Select.
M			X				For MonSw.state, refer to MonSw.value.

(continued)

Table C-9. Data Share Points (Left Continued).

User Address	NvName	Field Name	Engineering Units: English (Metric) or States plus Range	Digital State or Value of State	Default
	nvilaqOvr	value	0 to 100		0
DestlaqOvrD	nvilaqOvr	state	SW_OFF SW_ON SW_NUL	0 1 255	SW_NUL
SrclaqOvrCt	nvolaqOvr	value	0 to 100		0
SrclaqOvr	nvolaqOvr	state	SW_OFF SW_ON SW_NUL	0 1 255	SW_NUL

Table C-9. Data Share Points (Right Continued).

E-Vision (EV): Calibrate (C), Monitor (M), Parameter (P), Schematic (S) Share (SH), Map (MA), Direct Access (DA) Hardware Configuration (HW), Manual Configuration (MN), Test (TS)							Comments
EV	SH	MA	DA	HW	MN	TS	
							laqOvr allows an indoor air quality sensor to be shared by many other nodes. The states are follows: If the state is SW_OFF and the value is don't care, then the indoor air quality is acceptable. If the state is SW_ON and the value is 0, then the indoor air quality is acceptable. If the node receives this combination of state and value, then state is set to SW_OFF. If the state is SW_ON and the value is not zero, then the indoor air quality is not acceptable and additional outdoor air is needed to bring it back to acceptable. If the state is SW_NUL and the value is don't care, then the indoor air quality is acceptable. If the state is other, then the network variable is not bound, the communications path from the sending node has failed, or the sending node has failed. The indoor air quality is acceptable.
M	X		X		X		For laqOvr.state, refer to laqOvr.value.
X	X						laqOvr allows an indoor air quality sensor to be shared with other nodes and is typically bound to laqOvr on other nodes. If Data2.siSpaceCo2 is not SI_INVALID, and exceeds Aux1SetPt.CO2Iaqlimit, then poor air quality is detected. In addition, if a local digital input is configured for IAQ_OVERRIDE_IN and IO.IaQOverRide is 1 (TRUE) then poor air quality is also detected. The state has the following meanings: If the state is SW_OFF and the value is 0, then the indoor air quality is acceptable. If the state is SW_ON and the value is 100 percent, then the indoor air quality is not acceptable and additional outdoor air is needed to bring it back to an acceptable state. If the state is SW_NUL and the value is 0, then the economizer for this node has not been configured or there is no sensor (via IO.SpaceDo2 or IO.IaQOverRide) configured or the only configured sensor (via IO.SpaceCo2) has failed.
M	X		X				For laqOvr.State, refer to laqOvr.value.

## Appendix D. Q7750A Excel 10 Zone Manager Point Estimating Guide.

Memory size approximation is shown below: (all sizes in bytes)

When *memory size* is less than 110,000 bytes, the size is OK.

When *memory size* is between 110,000 and 128,000 bytes, the application may be too large. The user must expect to reduce the application complexity, reduce the number of attached Excel 10s or distribute the Excel 10s over more than one Zone Manager.

When *memory size* is greater than 128,000, the size is too large. The application size must be reduced as described above.

### Approximate Memory Size Estimating Procedure.

1. Determine the number of points per controller required at the Central (for example, XBS).

NOTE: All remaining points that are not mapped can be accessed through the *Direct Access* feature.

2. Calculate the number of Excel 10 Zone Manager program points that are used in control logic and in the switching table.
3. Estimate the program complexity of the Zone Manager (one of three levels).
  - a. No time programs, control logic, or switching tables.
  - b. 10K of control logic (one time program, five switching tables, and five control loops).
  - c. 20K of control logic (multiple time programs, ten switching tables, and ten control loops).

Use Fig. D-1 to determine the number of Excel 10s that can be connected to the Zone Manager.

NOTE: More than 60 Excel 10s requires a Router.

4. Repeat for each Q7750A Excel 10 Zone Manager in a project.

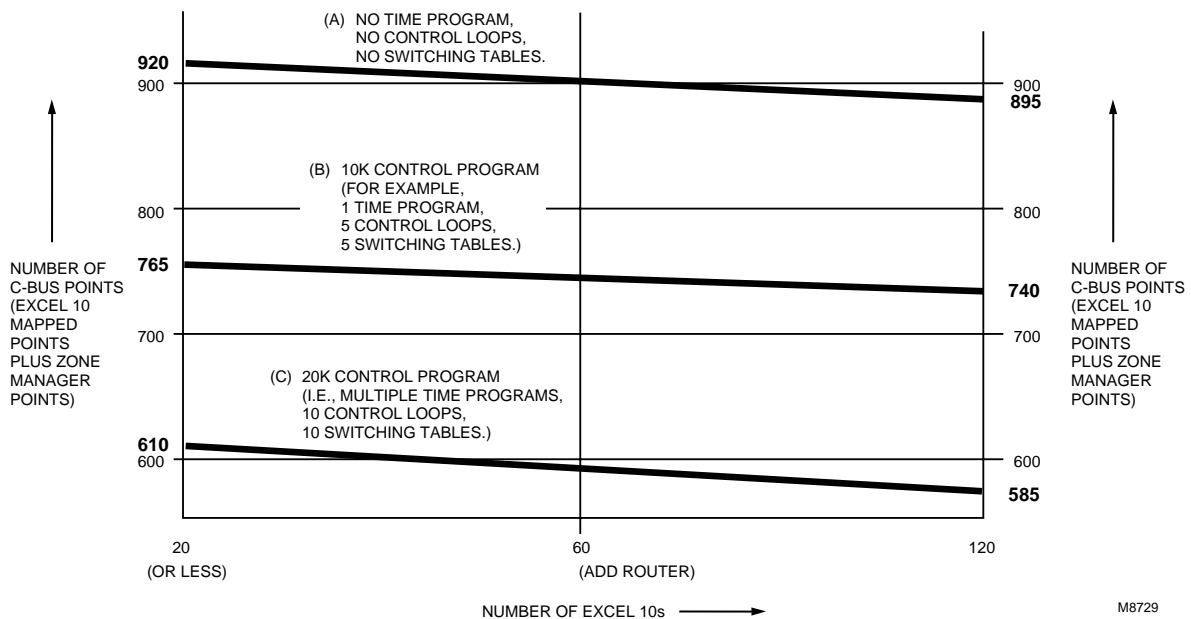

Fig. D-1. Point capacity estimate for Zone Manager.

The exact equation for calculating memory size follows:

$$\begin{aligned}
 &\text{Memory size} = 21,780 \\
 &+ 4096 \text{ (in case of a time program).} \\
 &+ \text{CARE Control Program.} \\
 &+ 14 \times \text{time points} \times \text{Excel 10 units.} \\
 &+ 50 \times \text{Excel 10 units.} \\
 &+ \text{map complexity} \times \text{Excel 10 units} \times \text{mapped points.} \\
 &+ 57 \times \text{C-Bus points.} \\
 &+ 7488 \times \text{Excel 10 types.}
 \end{aligned}$$

Where:

- Time points = number of switch points in time program per Excel 10.
- Excel 10 units = number of attached Excel 10s.
- C-Bus points = including mapped points and others; for example, remote points.
- Mapped points = number of mapped points per Excel 10, including One-to-Many and Many-to-One mechanism.
- Excel 10 types = number of different Excel 10 types (currently three)

Map complexity =  
 20 = using One-to-Many and not using points with read/write.  
 30 = average.  
 45 = many points with read/write ability.

**Appendix E. Sensor Data for Calibration.**

**Resistance Sensors.**

**Sensor Type:**  
 C7100A, (and C7170A)

**Sensor Use:**  
 Discharge air, Outdoor air

Table E-1 lists the points for Sensor Resistance versus Temperature. Fig. E-1 shows the graph of these points.

**Table E-1. Sensor Resistance Versus Temperature.**

°F	Resistance Ohms
-40	2916.08
-30	2964.68
-20	3013.28
-10	3061.88
0	3110.48
10	3159.08
20	3207.68
30	3256.28
40	3304.88
50	3353.48
60	3402.08
70	3450.68
80	3499.28
90	3547.88
100	3596.48
110	3645.08
120	3693.68

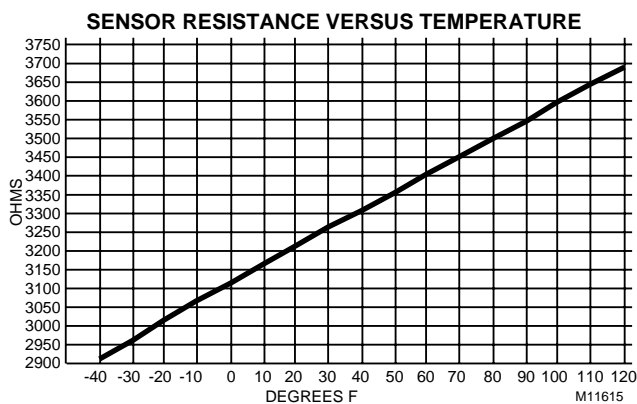

**Fig. E-1. Graph of Sensor Resistance versus Temperature.**

**Sensor Type:**  
 C7031B1033, C7031C1031 C7031D1062, C7031F1018, C7031J1050, C7031K1017

**Sensor Use:**  
 Return Air, Discharge Air Temperature

Table E-2 lists the points for Sensor Resistance versus Temperature. Fig. E-2 shows the graph of these points.

**Table E-2 Sensor Resistance Versus Temperature.**

°F	Resistance Ohms
30	1956.79
35	1935.79
40	1914.79
45	1893.79
50	1872.79
55	1851.79
60	1830.79
65	1809.79
70	1788.79
75	1767.79
80	1746.79
85	1725.79
90	1704.78
95	1683.78
100	1662.78
105	1641.78
110	1620.78
115	1599.78
120	1578.78

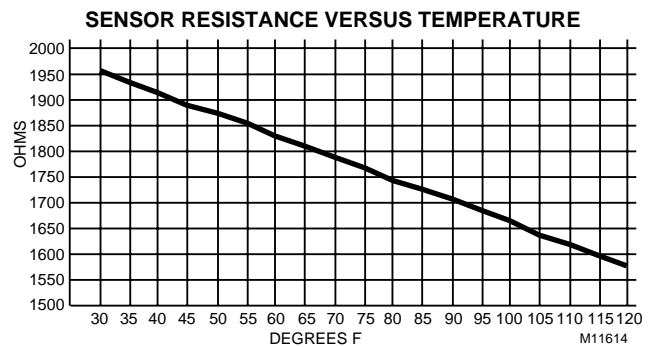

**Fig. E-2. Graph of Sensor Resistance versus Temperature.**

**Sensor Type:**  
 T7770A,B,C,D and C7770A

**Sensor Use:**  
 Space Temperature and Discharge/Return Air Temperature

Table E-3 lists the points for Sensor Resistance versus Temperature. Fig. E-3 shows the graph of these points.

**Table E-3 Sensor Resistance Versus Temperature.**

°F	Resistance Ohms
40	9961.09
45	9700.90
50	9440.72
55	9180.53
60	8920.35
65	8660.16
70	8399.98
75	8139.79
80	7879.61
85	7619.42
90	7359.24
95	7099.06
100	6838.87

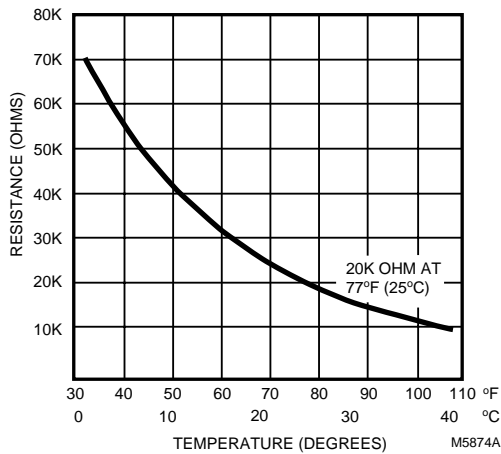

**Fig. E-3. Graph of Sensor Resistance versus Temperature.**

**Sensor Type:**  
T7770B,C 10K ohm setpoint potentiometer (Relative)

**Sensor Use:**  
Offset Setpoint Temperature

Table E-4 lists the points for Sensor Resistance versus Temperature. Fig. E-4 shows the graph of these points.

**Table E-4 Sensor Resistance Versus Temperature.**

°F Above and Below Setpoint	Resistance Ohms
-9	8877.41
-8	8832.14
-7	8786.87
-6	8741.60
-5	8696.33
-4	8651.06
-3	8605.79
-2	8560.52
-1	8515.25
0	8469.98
1	8424.71
2	8379.45
3	8334.18
4	8288.91
5	8243.64
6	8198.37
7	8153.10
8	8107.83
9	8062.56

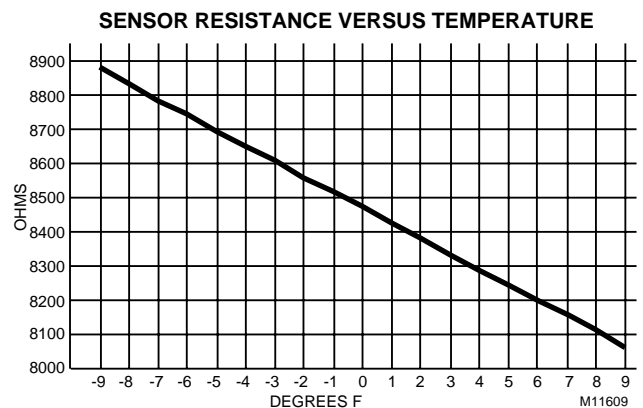

**Fig. E-4. Graph of Sensor Resistance versus Temperature.**

**Sensor Type:**  
T7770B,C 10 K ohm setpoint potentiometer (Absolute)

**Sensor Use:**  
Direct Setpoint Temperature

Table E-5 lists the points for Sensor Resistance versus Temperature. Fig. E-5 shows the graph of these points.

**Table E-5 Sensor Resistance Versus Temperature.**

°F	Resistance Ohms
55	8877.42
60	8741.62
65	8605.82
70	8470.02
75	8334.22
80	8198.42
85	8062.62

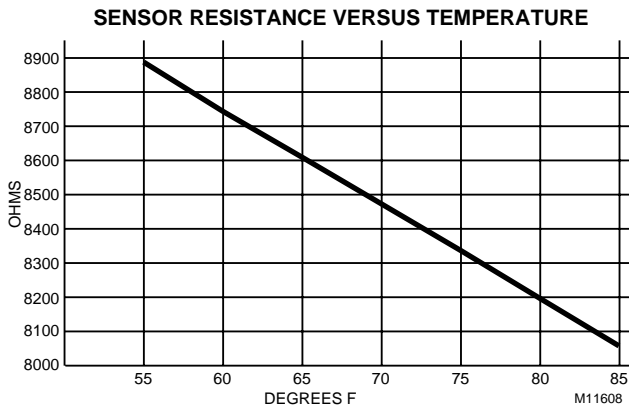

**Fig. E-5. Graph of Sensor Resistance versus Temperature.**

**Voltage/Current Sensors.**

**Sensor Type:**  
C7600B1000 2 to 10V (Decorative Wall Mount)

**Sensor Use:**  
Humidity

Table E-6 lists the points for Sensor Voltage versus Humidity. Fig. E-6 shows the graph of these points.

**Table E-6 Sensor Voltage Versus Humidity.**

Humidity Percentage	Sensor Voltage
10	2.67
15	3.08
20	3.48
25	3.88
30	4.28
35	4.68
40	5.08
45	5.48
50	5.88
55	6.28
60	6.69
65	7.09
70	7.49
75	7.89
80	8.29
85	8.69
90	9.09

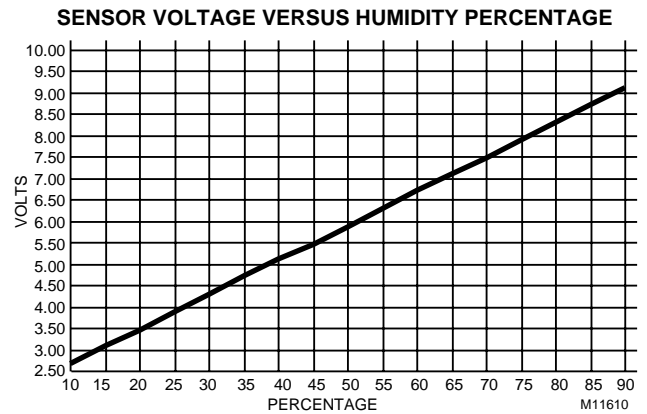

**Fig. E-6. Graph of Sensor Voltage versus Humidity.**

**Sensor Type:**  
C7600C (4 to 20 mA)

**Sensor Use:**  
Humidity

Table E-7 lists the points for Sensor Voltage versus Humidity. Fig. E-7 shows the graph of these points.

**Table E-7 Sensor Voltage Versus Humidity.**

Relative Humidity Percentage	Sensor Voltage
10	5.6
20	7.2
30	8.8
40	10.4
50	12.0
60	13.6
70	15.2
80	16.8
90	18.4

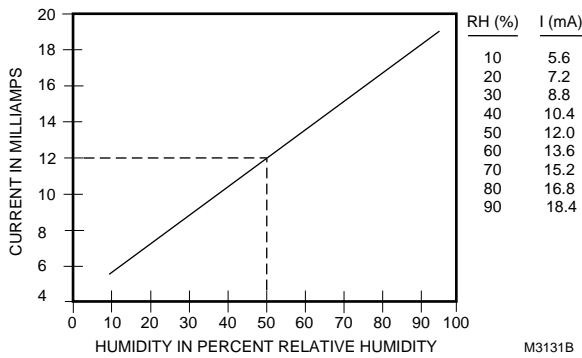

**Fig. 7. C7600C output current vs. humidity.**

**Sensor Type:**  
T7400A1004

**Sensor Use:**  
Enthalpy

Table E-8 lists the points for Sensor Current versus Enthalpy (volts). Fig. E-8 shows the graph of these points.

**Table E-8 Sensor Current Versus Enthalpy (volts).**

Enthalpy (mA)	Sensor Current
4	1
5	1.25
6	1.49
7	1.74
8	1.99
9	2.24
10	2.49
11	2.74
12	2.99
13	3.24
14	3.49
15	3.74
16	3.98
17	4.23
18	4.48
19	4.73
20	4.98

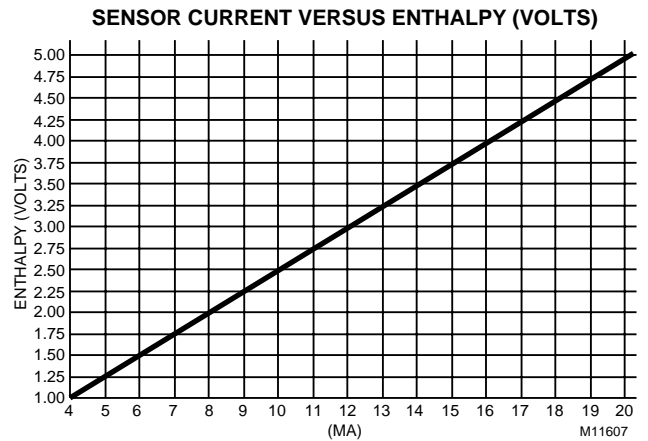

**Fig. E-8. Graph of Sensor Current versus Enthalpy (volts).**

See Fig. E-9 for partial psychrometric chart for a C7400A Solid State Enthalpy Sensor.

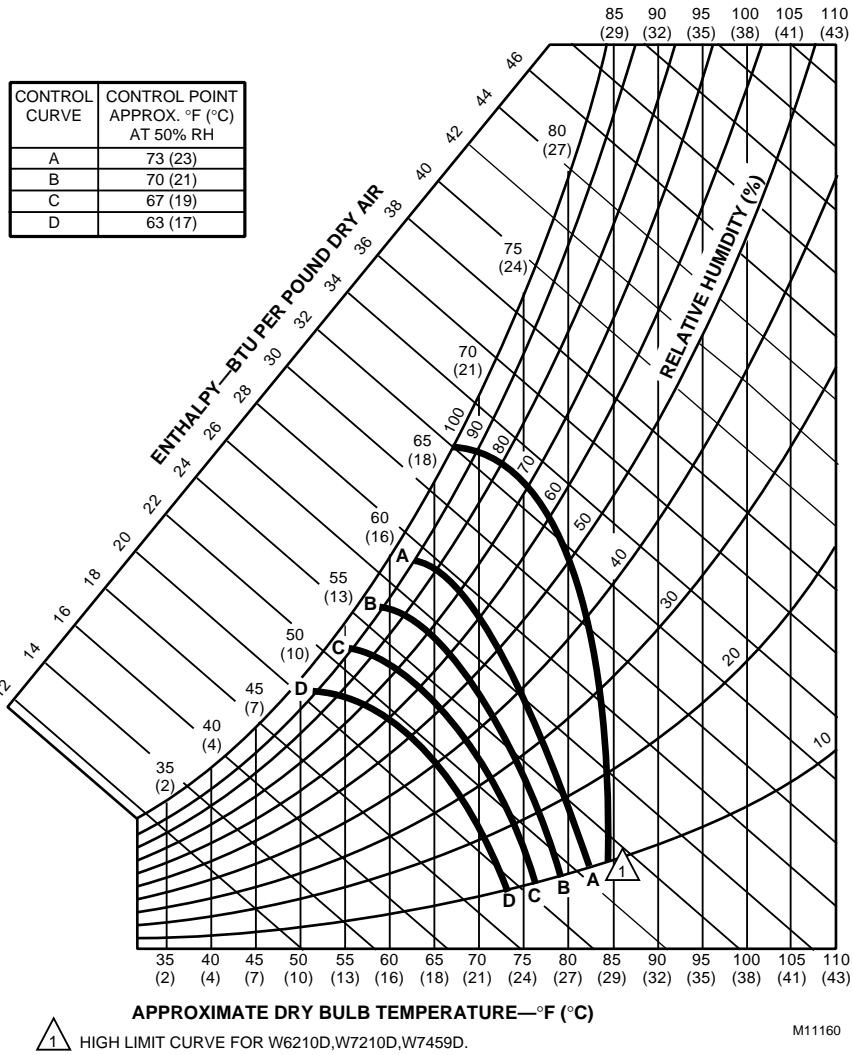

Fig. E-9. Partial psychrometric chart for a C7400A Solid State Enthalpy Sensor.

See Fig. E-10 for a C7400A Solid State Enthalpy Sensor output current vs. relative humidity.

**Sensor Type:**  
T7242 or equivalent

**Sensor Use:**  
CO<sub>2</sub> concentration

Table E-11 lists the points for Sensor Voltage versus CO<sub>2</sub> concentration. Fig. E-11 shows the graph of these points.

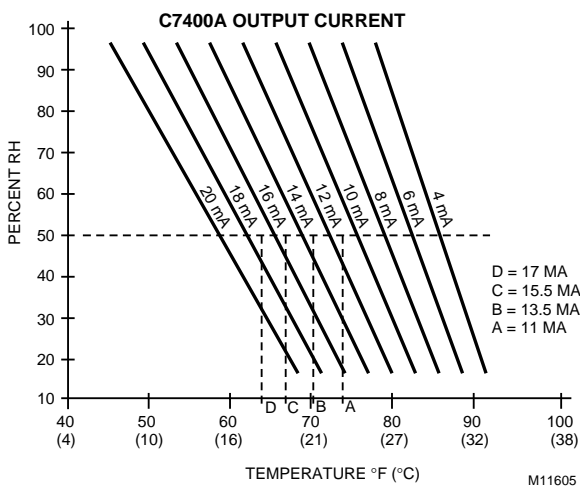

Fig. E-10. C7400A Solid State Enthalpy Sensor output current vs. relative humidity.

**Table E-11 Sensor Voltage Versus CO<sub>2</sub> Concentration.**

CO <sub>2</sub> Concentration PPM	Sensor Voltage
0	0.00
100	0.50
200	1.00
300	1.50
400	2.00
500	2.50
600	3.00
700	3.50
800	4.00
900	4.50
1000	5.00
1100	5.50
1200	6.00
1300	6.50
1400	7.00
1500	7.50
1600	8.00
1700	8.50
1800	9.00
1900	9.50
2000	10.00

**Table E-12 Sensor Voltage Versus Input Voltage To A/D.**

Voltage to A/D	Sensor Voltage
0.00	0.00
0.50	0.25
1.00	0.50
1.50	0.75
2.00	1.00
2.50	1.25
3.00	1.50
3.50	1.75
4.00	2.00
4.50	2.25
5.00	2.50
5.50	2.75
6.00	3.00
6.50	3.25
7.00	3.50
7.50	3.75
8.00	4.00
8.50	4.25
9.00	4.50
9.50	4.75
10.00	5.00

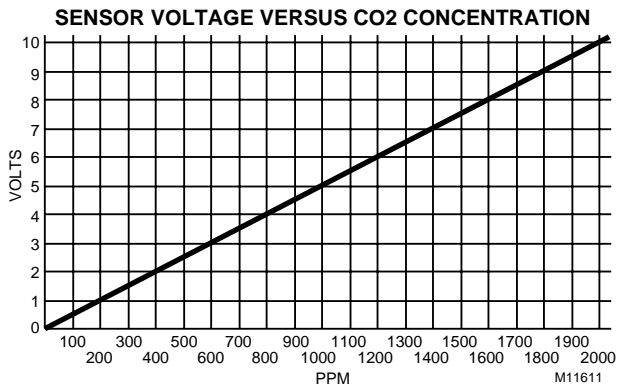
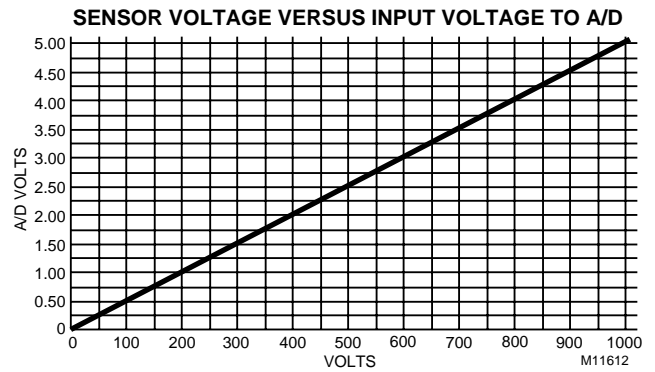

**Fig. E-11. Graph of Sensor Voltage versus CO<sub>2</sub> concentration.**

**Sensor Type:**  
Third party (2 to 10V)

**Sensor Use:**  
Monitor voltage

Table E-12 lists the points for Sensor Voltage versus input Voltage to A/D. Fig. E-12 shows the graph of these points.



**Fig. E-12. Graph of Sensor Voltage versus input Voltage to A/D.**

**Sensor Type:**  
Third party

**Sensor Use:**  
Sensor Voltage (Vdc) /Pressure (Inw) 2 to 10V, 0 to 5 inw (1.25 kPa)

Table E-13 lists the points for Sensor Voltage (Vdc) versus Pressure (Inw). Fig. E-13 shows the graph of these points.

**Table E-13 Sensor Voltage (Vdc) Versus Pressure (Inw).**

Pressure Inw (kPa)	Sensor Voltage (Vdc)
0.00 (0.00)	2.00
0.50 (0.13)	2.80
1.00 (0.25)	3.60
1.50 (0.37)	4.40
2.00 (0.5)	5.20
2.50 (0.62)	6.00
3.00 (0.75)	6.80
3.50 (0.87)	7.60
4.00 (1.00)	8.40
4.50 (1.12)	9.20
5.00 (1.25)	10.00

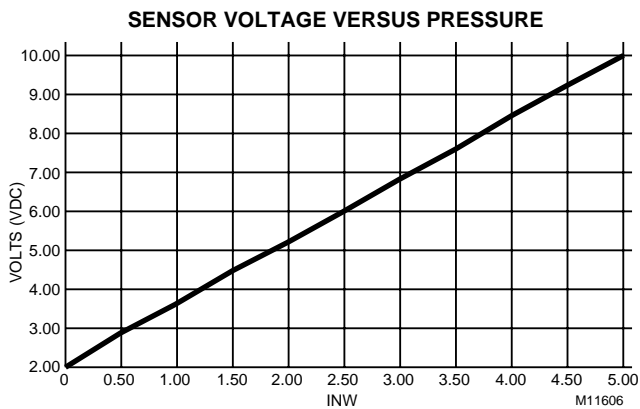

**Fig. E-13. Graph of Sensor Voltage (Vdc) versus Pressure (Inw).**





**Home and Building Control**  
Honeywell Inc.  
Honeywell Plaza  
P.O. Box 524  
Minneapolis, MN 55408-0524

**Home and Building Control**  
Honeywell Limited-Honeywell Limitee  
155 Gordon Baker Road  
North York, Ontario  
M2H 3N7

**Home and Building Control Products**  
Honeywell AG  
Böblinger Straße 17  
D-71101 Schönaich  
Phone (49-7031) 637-01  
Fax (49-7031) 637-493

**Honeywell**

